

Framed combinatorial topology

Christoph Dorn & Christopher L. Douglas

MATHEMATICAL INSTITUTE, UNIVERSITY OF OXFORD, OXFORD OX2
6GG, UNITED KINGDOM
Email address: `dorn@maths.ox.ac.uk` & `cdouglas@maths.ox.ac.uk`

2020 *Mathematics Subject Classification*. Primary 57N80, 57Q25, 57Q15, 57N60; Secondary 57Q65, 57R05, 57R45, 58K05, 58K60, 55U10, 55R55, 05E45, 06A07, 18N20.

Key words and phrases. Combinatorial topology, piecewise linear, stratified space, regular cellulation, decidability, Hauptvermutung, constructible bundle, string diagram, manifold diagram, framing, truss, mesh, tangle, tame, singularity.

Dedicated to our grandparents:
Dietlinde Schmidt and Winfried Wegener,
Johanna Sternberg and Fritz Dorn;
Laia Perlmutter and Richard Hanau,
Julia Huntington and Randall Douglas.

Contents

Introduction	ix
I.1. Computability in combinatorial topology	x
I.2. Combinatorializability of topological phenomena	xii
I.3. Summary	xiv
I.4. Overview	xxiv
I.5. Outlook	xxviii
Acknowledgments	xxx
Chapter 1. Framed combinatorial structures	1
1.1. Framed simplices	2
1.1.1. Frames, partial frames, and embedded frames	3
1.1.2. Framed maps	18
1.2. Framed simplicial complexes	27
1.2.1. Framings on simplicial complexes	28
1.2.2. Collapsible framings	34
1.3. Framed regular cell complexes	41
1.3.1. Regular cell complexes	42
1.3.2. Framings on regular cell complexes	51
Chapter 2. Constructible framed combinatorics: trusses	71
2.1. 1-Trusses, bordisms, and bundles	72
2.1.1. 1-Trusses	74
2.1.2. 1-Truss bordisms	81
2.1.3. 1-Truss bundles	97
2.2. Truss induction and labelings	110
2.2.1. Sections and spacers	111
2.2.2. The scaffold order	118
2.2.3. Labeled 1-trusses, bordisms, and bundles	125
2.3. n -Trusses, bordisms, bundles, and blocks	140
2.3.1. n -Trusses and their bordisms	141
2.3.2. n -Truss bundles and their classification	150
2.3.3. n -Truss blocks and block sets	163
Chapter 3. Constructibility of framed combinatorial structures	177
3.1. Overview of the classifications	178
3.2. Proframed combinatorial structures	180
3.2.1. Proframed simplices	181
3.2.2. Proframed simplicial complexes	188
3.3. Proofs of the classifications	196
3.3.1. Integrating framed regular cells	197
3.3.2. Functors between collapsible cell complexes and trusses	202
3.3.3. Equivalences of framed cell and truss structures	208

Chapter 4. Constructible framed topology: meshes	210
4.1. 1-Meshes, 1-mesh bundles, and n -meshes	211
4.1.1. 1-Meshes	212
4.1.2. 1-Mesh bundles	216
4.1.3. n -Meshes and their bundles	232
4.2. Weak equivalence of meshes and trusses	243
4.2.1. Overview of the equivalences	244
4.2.2. Fundamental trusses	248
4.2.3. Essential injectivity of the fundamental truss functor	252
4.2.4. Weak faithfulness of the fundamental truss functor	259
4.2.5. Mesh realizations	263
4.2.6. Proofs of the equivalences and their applications	276
Chapter 5. Tame stratifications and their combinatorializability	286
5.1. Tame stratifications and tame embeddings	287
5.1.1. The definitions	288
5.1.2. Overview of the classification	294
5.1.3. Preview of applications	296
5.2. Coarsest meshes	300
5.2.1. Mesh joins	301
5.2.2. The coarsest mesh constructions	308
5.2.3. Examples of coarsest meshes	312
5.3. Tractability of tame stratifications	316
5.3.1. Combinatorializability	317
5.3.2. Polyhedrality	331
5.3.3. Computability	339
5.4. Coda on manifold diagrams and tame tangles	351
5.4.1. Manifold diagrams	352
5.4.2. Tame tangles	359
Appendix A. Linear and affine frames	368
Appendix B. Stratified topology	384
Appendix C. A menagerie of framed regular cells	417
Bibliography	427
List of Figures	432
List of Notation	440
Index of Terms	448

INTRODUCTION

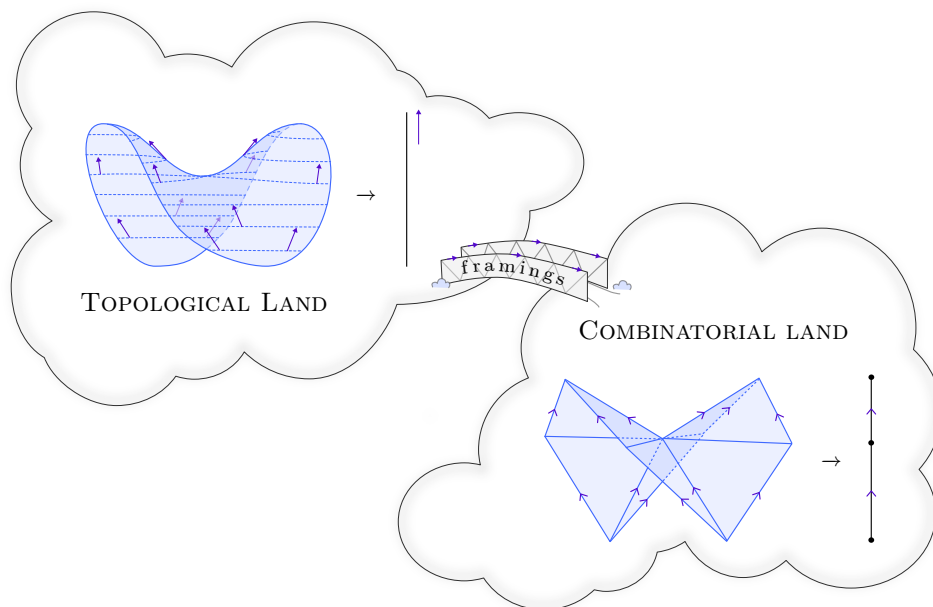

Framed combinatorial topology is a novel theory providing a combinatorial description of phenomena that arise at the intersection of stratified topology, singularity theory, and higher algebra. The theory synthesizes elements of classical combinatorial topology with a new combinatorial approach to framings. The resulting notion of framed combinatorial spaces has unexpectedly good behavior when compared to classical, nonframed combinatorial notions of space. In discussing this behavior and its contrast with that of classical structures, we emphasize two broad themes, ‘computability in combinatorial topology’ and ‘combinatorializability of topological phenomena’. The first theme of computability concerns whether certain combinatorial structures (such as simplicial complexes homeomorphic to spheres) can be algorithmically recognized and classified. The second theme of combinatorializability concerns whether certain topological structures (such as manifolds) can be faithfully described by discrete combinatorial means. Combining these themes, we will find that in the context of framed combinatorial topology we can overcome a set of fundamental classical obstructions to the computable combinatorial representation of topological phenomena.

A preliminary version of this work appeared as arXiv:2112.14700.

We begin this introduction by elaborating the themes of computability and of combinatorializability in, respectively, Section I.1 and Section I.2. We then give a more formal overview of our results in Section I.3, a chapter-by-chapter outline in Section I.4, and an outlook on the larger program and aims of the subject in Section I.5.

I.1. Computability in combinatorial topology

Computability is the ability to solve a general problem by a general method, that is, the ability to write a step-by-step procedure which for each specific instance of a problem computes a solution. Combinatorial topology provides, in a sense, a computation-oriented foundation for the study of spaces, by encoding space in discrete structures [RS72, Bry02]. However, many fundamental problems in combinatorial topology turn out to be computably intractable; such problems include the following [Mar58, VKF74, CL06, Wei05]:

- › *Disk recognition.* The statement ‘The simplicial complex K is homeomorphic to the n -disk’ cannot be computably verified for general finite complexes K . This uncomputability issue remains in the piecewise linear setting: the statement ‘The simplicial complex K piecewise linearly subdivides the n -simplex’ cannot be verified. In particular, one cannot constructively enumerate all topological subdivisions of the n -disk, nor all piecewise linear subdivisions of the n -simplex.
- › *Homeomorphism problem.* More generally, it is impossible to algorithmically decide whether two simplicial complexes K and L have homeomorphic, or piecewise linearly homeomorphic, geometric realizations. Similarly, given two embedded, or piecewise linearly embedded, simplicial complexes $K \hookrightarrow \mathbb{R}^n$ and $L \hookrightarrow \mathbb{R}^n$, one cannot in general determine whether the embeddings are ambient homeomorphic, respectively ambient piecewise linearly homeomorphic.
- › *Manifold classification.* Similarly, the statement ‘The simplicial complex K is homeomorphic to a manifold’ cannot be computably verified in general, and neither can the statement ‘The simplicial complex K is a piecewise linear manifold’. In particular, one cannot constructively enumerate all simplicial complexes homeomorphic or piecewise linearly homeomorphic to manifolds, nor decidably classify homeomorphism or piecewise linear homeomorphism types of manifolds.

One could view these failures of computability as unavoidable imperfections of mathematics as we know it, or one can see them as failures of the classical simplicial methods of combinatorializing topological structures. Adopting the latter viewpoint, one may hope for a form of combinatorial topology with better computability properties, for instance in which one can recognize combinatorial disks, decide combinatorial homeomorphism, and classify combinatorial manifolds.

1 : Removed stratified variations here. Check this didn't remove something later presumed. If needed, need to rethink where, to keep flow and parallelism here, and reconsider text.

The first central theme of this book is that, though typical simplicial methods do not provide an entirely computable foundation for combinatorial spaces, there is a different approach, using *framed* combinatorial spaces, that may provide a more suitable infrastructure for computable combinatorial topology. Our theory of ‘framed combinatorial topology’ differs in two fundamental respects from classical piecewise linear topology: first, we endow simplices and simplicial complexes with a combinatorial framing structure, and second, we generalize the resulting class of ‘framed simplicial complexes’ to a broader class of ‘framed regular cell complexes’. Though classical regular cells are much less tractable even than simplices—indeed even the list of cell shapes is uncomputable—it will turn out that framed regular cells arise as iterated constructible combinatorial bundles and therefore both these cells and their complexes are, remarkably, algorithmically classifiable.

A classical frame of an m -dimensional vector space is an ordered choice of m linearly independent vectors. A combinatorial frame of an m -simplex will be an ordered choice of m vectors in the spine of the simplex. To make sense of a frame on a simplicial complex, we need a notion of the compatibility of frames along faces shared between simplices. The restriction of a frame of a simplex to a face gives not only information about a frame of the face but also about how that restricted frame embeds in the ambient frame of the simplex; we will be primarily concerned with the resulting notion of embedded framed simplex, and a *framed simplicial complex* will be a simplicial complex with compatible embedded frames on all its simplices.

Regular cell complexes, that is those complexes whose attaching maps are injective [LW69], generalize simplicial complexes by allowing cells of ‘polytopic’ shapes instead of merely ‘triangular’ shapes [Zie95]. Regular cells can be identified with the geometric realizations of their face posets [Bjö84], and via that identification they obtain piecewise linear simplicial subdivisions. A framing of a regular cell will be a framing of its simplicial subdivision, which is constructively framed contractible or ‘framed collapsible’, in the sense that it admits a collapse sequence respecting the frame order of its vectors. A *framed regular cell complex*, finally, will be a regular cell complex with compatible choices of framings on each of its cells.

A space with a homeomorphism to a regular cell complex is ‘cellulated’, as a space with a homeomorphism to a simplicial complex is ‘triangulated’. The fact that cellulated spaces have played a less prominent role than triangulated spaces in classical combinatorial topology is partially due to the aforementioned fundamental computability obstruction: it is impossible to classify all the possible shapes of regular cells, in the sense that one cannot produce a list of all regular cells with a given number of faces, in general; said another way, there is no general algorithm for deciding whether a given poset is the face poset of a regular cell, even though there are only finitely many posets of a given size. Endowing regular cells with a framing overcomes

2 : Check happy with first two sentences here, given new analogy structure

3 : Discuss citation logic

this fundamental issue: framed regular cells, in contrast to their nonframed counterparts, are classifiable. Specifically, given a poset together with a framing of its nerve simplicial complex, we can algorithmically recognize whether the poset is the face poset of a framed regular cell. That recognition is possible because we will classify framed collapsible regular cell complexes by a novel elementary combinatorial structure, called *trusses*, which are iterated constructible bundles of oriented fence posets.

Framed regular cells strike an unlikely and delicate balance, being simultaneously a class of shapes that is tractable (unlike ordinary regular cells) and also a class of shapes that is quite general (unlike ordinary simplices). The generality of the shapes of framed regular cells provides unique combinatorial representatives in a way that is unthinkable with simplicial structures and unknown with any other class of shapes. Notably, framed regular cell complexes that admit a framed map to euclidean space, concisely called *n-directed acyclic graphs*, have computable unique coarsest cell structures. Having a computably unique representation of these complexes makes algorithmically decidable almost any question about them; for instance, it follows that framed homeomorphism of *n*-directed acyclic graphs is decidable, in stark contrast to the classical (nonframed simplicial) situation. In this and other related respects, working with framed regular cells and their complexes provides, finally, a computable framework for combinatorial models of spaces.

I.2. Combinatorializability of topological phenomena

Combinatorics is primarily concerned with discrete, and often finite, structures whose constituents can be counted. Topology, by contrast, is primarily concerned with the continuous structure of spaces. The ‘combinatorializability’ of topological phenomena refers to the ability to faithfully encode continuous objects (spaces, manifolds, continuous maps, bordisms, et cetera) in discrete or finite data structures. This faithful encoding depends both on having a combinatorial representation of the object in question, and on knowing that representation is unique up to some specified combinatorial equivalence relation.

There are by now various known instances of topological phenomena that cannot be faithfully combinatorialized, or even combinatorialized at all, giving an impression of a mysterious and insurmountable divide between topological spaces and any discrete representations of those spaces. A headline instance of this divide is the disproven *Hauptvermutung*, a conjecture that, roughly speaking, claimed that topological homeomorphism coincides with piecewise linear homeomorphism [RCS⁺96]. This conjecture would in particular imply that combinatorial spaces (that is, geometric realizations of simplicial complexes) that are homeomorphic are also piecewise linear homeomorphic. This intuitive, presumptive claim was eventually disproven [Mil61] by the explicit construction of homeomorphic finite simplicial complexes that are not piecewise linear homeomorphic.

Consider this list of references. [I moved refs to end of sentence. Ethan Akin ref removed. Selection is a bit biased? (Could cover more topics?) But also we go into more details below.]

A flurry of results followed in subsequent decades, quantifying the divide not only between the ‘continuous’ and the ‘combinatorial’, but also between the ‘combinatorial’ and the ‘smooth’ conceptions of space [KS69, HM74, Fre82, Don83]. Recently, a disproof of the triangulation conjecture [Man16] established an especially stark gap, that in every dimension greater than 4 there exist compact topological manifolds that do not even admit a triangulation. (It will be pertinent later that most instances of the classical topological–combinatorial gap rely on certain infinitary or ‘wild’ topological constructions.) By contrast, smooth manifolds always admit triangulations and all triangulations of a smooth manifold are combinatorially equivalent [Whi40]. However, smooth manifolds that are not smoothly isomorphic may nevertheless be combinatorially isomorphic [Mil56], and combinatorial manifolds need not admit any smooth structure [Ker60].

One might dream of a topological foundation or combinatorial framework in which the mismatch between the continuous, combinatorial, and smooth conceptions of space would, at least to some extent, be lessened. One could imagine, for instance, either a discrete, perhaps infinitary, combinatorial theory that faithfully represents a delineated class of relevant continuous phenomena, or a discrete, perhaps finitary, combinatorial theory that suitably encodes smooth behavior. Each of those two comparative visions has been pursued, to some but not complete satisfaction: for instance, an ‘o-minimal’ approach to tame topology provides a method for excluding certain wild topological structures [VdD98, Shi14], while a ‘matroid’ perspective aims for a direct combinatorial description of smooth structures [Mac93, GM92, BLVS⁺99].

The second central theme of this book is that, in contrast to the classical gap between topological and combinatorial phenomena, in our framed combinatorial setting there is a faithful comparison between framed topological and framed combinatorial phenomena. Furthermore, we expect framed combinatorial structures also faithfully encode all framed smooth phenomena, and therefore will provide an unexpected unification of the continuous, combinatorial, and smooth perspectives on space. Our framed topological structures will be a form of *topologie modérée* [Gro97] called ‘tame stratifications’. These stratifications are framed by an embedding in standard euclidean space, and they are tame in that they admit a refining ‘mesh’, which is a cellulation by framed regular cells; this cellulation requirement is analogous to working with triangulable spaces and therefore excluding, a priori, certain wild behavior. These refining meshes are iterated constructible bundles of stratified 1-manifolds, and will be a precise topological counterpart of the iterated constructible combinatorial structure of trusses mentioned earlier.

The chain of associations, from a tame stratification to its mesh cellulation to the corresponding combinatorial truss, does not by itself necessarily ensure a faithful combinatorialization of tame stratified topology. As a space can have various inequivalent triangulations, a tame stratification could in theory have

various inequivalent meshes (and therefore corresponding trusses)—however, we will prove, crucially, that such a stratification always has a unique coarsest compatible mesh. This uniqueness is an unexpected and stark counterpoint to the classical situation: given two triangulations of a space, traditionally one aims (and fails) to construct a mutual *refinement* and thereby verify their combinatorial equivalence; now instead, given two mesh cellulations of a stratification, we construct a canonical mutual *coarsening* and thus establish the desired combinatorial equivalence. The proof of this canonical coarsening relies, of course, on the generality of the shapes of framed regular cells. The truss of the coarsest mesh refinement of a tame stratification provides the desired faithful combinatorialization of topological phenomena in standard framed euclidean space. Crucially, in this connexion, we will also establish the *framed Hauptvermutung*, that framed stratified homeomorphism classes coincide with framed stratified piecewise linear homeomorphism classes.

Regarding the combinatorialization of smooth phenomena, we will conjecture that any smooth manifold can be represented as a tame stratification (via a generic embedding in euclidean space) and that the resulting combinatorial representation as a truss faithfully encodes the smooth structure. The plausibility of that latter conjecture relies on the rigid structure of tame stratifications, built up constructively and inductively from elementary stratified intervals, according to the combinatorial arrangement of the classifying truss and with insufficient slack for exotic identifications.

I.3. Summary

We collect and summarize our main theorems, and along the way further describe and illustrate our core definitions. Recall that a framed simplex is an ordinary simplex together with a frame, that is, a choice of order of its spine vectors. More generally, a framed regular cell is an ordinary regular cell together with a suitably compatible choice of frames on each simplex in the cell's face poset. Though it is impossible to classify regular cells, by contrast framed regular cells are classifiable. The classifying combinatorial structure will be a special case of the notion of *trusses*, which are iterated constructible poset bundles defined as follows.

DEFINITION 1 (Trusses; Defs. 2.1.6, 2.1.74, 2.3.1). *A **1-truss** is a fence poset equipped with a total frame order on its elements. An n -truss is a length- n tower of constructible bundles of 1-trusses.*

Elements of a 1-truss that are targets of poset arrows are called 'singular' or 'dimension 0', while elements that are sources of poset arrows are called 'regular' or 'dimension 1'. A 1-truss is 'closed' if both its endpoints are singular, and 'open' if both are regular; an n -truss is 'closed' or 'open' if all its fiber 1-trusses are closed or open respectively. In Figure I.1 we illustrate a closed 2-truss and an open 3-truss; singular elements are red, regular elements are blue, and the frame orders are indicated by green arrows.

4 : rephrase to give
defs and theorems
comparable weight

5 : Begin careful re-
view here

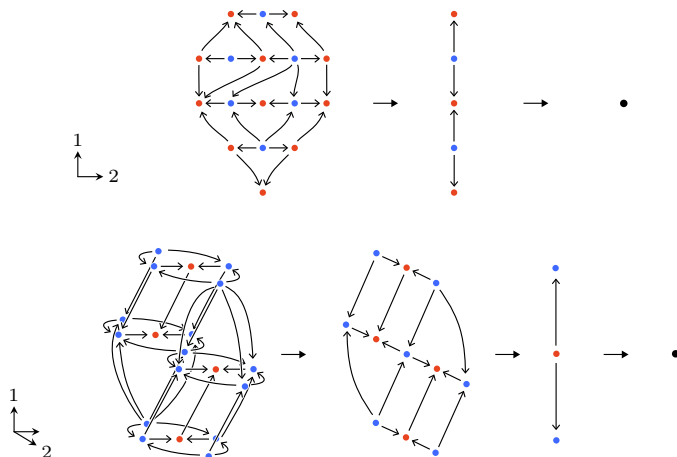

FIGURE I.1. A closed 2-truss and an open 3-truss.

A closed truss is called a ‘truss block’ if its total poset has an initial element; these truss blocks provide the combinatorial correlate of framed regular cells.

THEOREM 2 (Classification of framed regular cells; Thm. 3.1.1). *The category of framed regular cells is equivalent to the category of truss blocks.*

More generally, not just framed regular cells, but collapsibly framed regular cell complexes are classified by all trusses (Theorem 3.1.2). The classification of framed regular cells will immediately imply the algorithmic enumerability of framed regular cells (Corollary 3.3.29).

Given a framed regular cell, the total poset of the classifying truss block is the face poset of the cell; sequentially projecting out frame vectors from this poset determines a tower of 1-truss bundles. In Figure I.2 and Figure I.3 we illustrate a few framed regular cells and their corresponding truss blocks. A more extensive menagerie of framed regular cells is kept in Chapter C.

The classification of framed regular cells by truss blocks implies a corresponding classification for framed regular cell complexes. As a regular cell complex is a presheaf on the category of regular cells (and their inclusions), whose cells embed into the complex [EZ50, Dug98], a framed regular cell complex is a presheaf on the category of framed regular cells (and their inclusions), whose framed cells embed into the complex. Let a ‘regular truss block complex’ be a presheaf on the category of truss blocks (and their injective maps), whose blocks embed into the complex.

THEOREM 3 (Classification of framed regular cell complexes; Thm. 3.1.3). *The category of framed regular cell complexes is equivalent to the category of regular truss block complexes.*

6 : Triangular globe, square pillow, globe cone, simplex, ravioli, truncated cube?

7 : Block sets (and block complexes) skipped

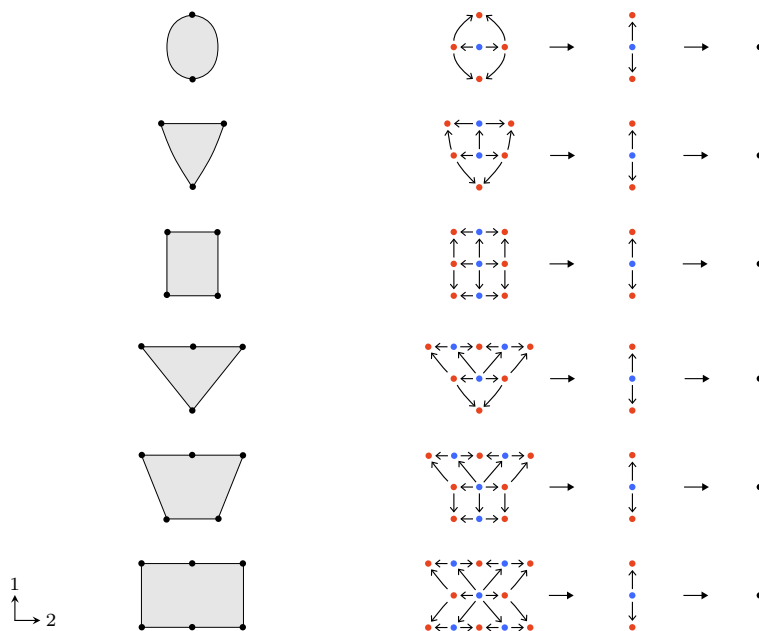

FIGURE I.2. Framed regular 2-cells and their classifying truss blocks.

Trusses have a stratified geometric realization as *meshes*, which are defined as iterated constructible bundles of stratified lines, analogously to Definition 1, as follows.

DEFINITION 4 (Meshes; Defs. 4.1.9, 4.1.28, 4.1.69). A **1-mesh** is a contractible 1- or 0-manifold, stratified by open intervals and points, and equipped with a framing. An **n -mesh** is a length- n tower of constructible bundles of 1-meshes.

An n -mesh is ‘closed’ if its total space is compact, and is ‘open’ if its total space is an open disc. In Figure I.4 we illustrate a closed 2-mesh and an open 3-mesh.

The correspondence of meshes and trusses is at the core of our combinatorialization of topological phenomena.

THEOREM 5 (Equivalence of meshes and trusses; Thm. 4.2.1). *The topological category of closed, respectively open, meshes is weakly equivalent to the discrete category of closed, respectively open, trusses.*

Recall that the fundamental poset of a stratified space has an element for each stratum and an arrow indicating when a stratum intersects the closure of another stratum. The above equivalence takes a mesh, a tower of stratified spaces, to the truss given by the tower of corresponding fundamental posets. As an illustration, note that the meshes in Figure I.4 yield, on application of fundamental posets, the trusses in Figure I.1.

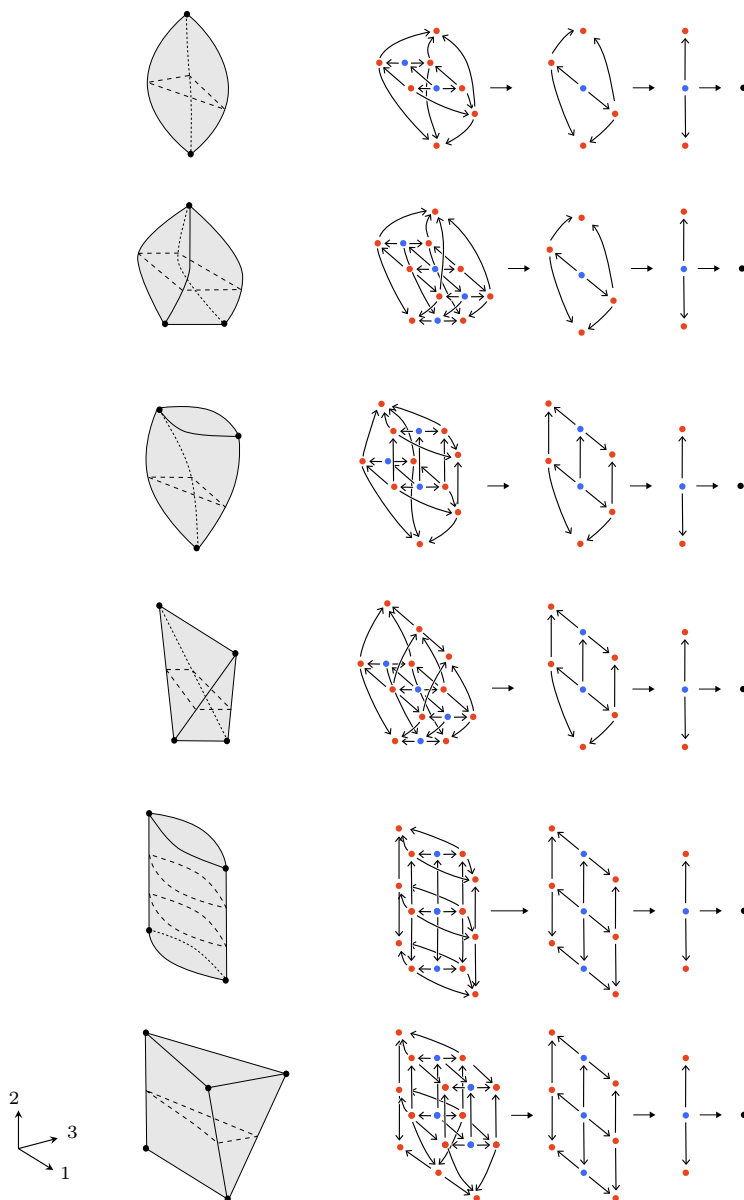

FIGURE I.3. Framed regular 3-cells and their classifying truss blocks.

A closed mesh will be called a ‘mesh block’ if its total space is the closure of a single stratum. Naturally, [Theorem 5](#) restricts to an equivalence of mesh blocks and truss blocks. Combining this equivalence with the earlier [Theorem 2](#), relating truss blocks and framed regular cells, yields a

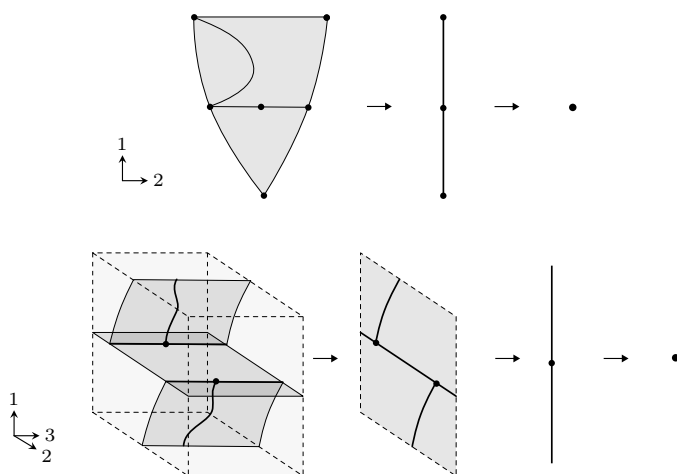

FIGURE I.4. A closed 2-mesh and an open 3-mesh.

correspondence of mesh blocks and framed regular cells (Corollary 4.2.84). Note well that regular cells are at root combinatorial objects and they come with a canonical piecewise linear structure, whereas mesh blocks are purely topological objects and a priori have no piecewise linear structure; thus this seemingly innocuous result provides a fundamental bridge between the topological and piecewise linear contexts.

8 : Reintroduced last paragraph, but without a display. Discuss.

Recall that a basic unsolvable problem of classical combinatorial topology is to classify subdivisions of the n -simplex. By contrast, leveraging the connection between framed regular cell complexes and regular truss block complexes, we can classify framed subdivisions of framed regular cells, in terms of ‘combinatorial subdivisions’ of truss blocks by trusses.

THEOREM 6 (Classification of framed cell subdivisions; Thm. 4.2.8). *A framed regular cell complex framed subdivides a framed regular cell if and only if it corresponds to a truss that combinatorially subdivides a truss block.*

In Figure I.5, we illustrate a framed regular cell subdivision along with its corresponding combinatorial truss block subdivision.

9 : I think this figure should change, for instance to have the corresponding truss subdivision alongside. Then it really does illustrate the theorem.

The category of closed trusses is isomorphic, via dualizing the truss posets, to the category of open trusses. By the equivalence of trusses and meshes established in Theorem 5, that combinatorial dualization of trusses translates to a geometric dualization of meshes.

From here to the break: not so clear why, really, this is here. [rewritten]

COROLLARY 7 (Dualization of meshes; Cor. 4.2.9). *Dualization is a weak equivalence between the topological category of closed meshes and the topological category of open meshes.*

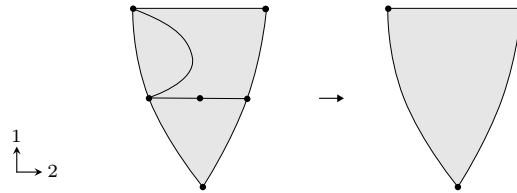

FIGURE I.5. A subdivision of a framed regular cell.

This self-duality is a crucial advantage meshes have over previously known shape categories. Note that the fundamental poset of the dual n -mesh is dual to the fundamental poset of the original mesh, and so the dimensions of all strata in the mesh are dualized—the collection of geometric shapes and their incidences is completely involuted. In Figure I.6, we illustrate the duality of meshes: in the first case, a 3-mesh block dualizes to an open 3-mesh with a single point stratum, and in the second case, a closed 3-mesh consisting of two blocks dualizes to an open 3-mesh with two point strata.

10 : Reconsider that figure line

Meshes are a flexible, computationally tractable class of highly structured stratifications; they furthermore provide access to a much broader, almost completely general class of stratifications by considering those stratifications that admit a refinement by a mesh, as follows.

If seeking smooth connection to previous section, reconsider how

DEFINITION 8 (Tame stratifications; Def. 5.1.1). *An **tame stratification** is a stratification of a subspace of euclidean space that admits a refinement by a mesh.*

In Figure I.7 we illustrate two tame stratifications of an open 4-cube, by depicting three pertinent slices. The first stratification is the classical third Reidemeister move, and the second is the classical swallowtail singularity; that these indeed admit mesh refinements is illustrated in a moment in Figure I.8 and Figure I.9.

At the heart of the computability of our combinatorial model of stratified framed topology is the rather unexpected fact that among the set of all refining meshes of a tame stratification, there is always a canonical *coarsest* choice. Heuristically, the coarsest refining mesh of a stratification is built up just from the indispensable critical loci of certain projections of the strata. Needless to say, this situation is in stark contrast to any simplicial model of (stratified) topology, in which two triangulations almost never have a mutual coarsening and typically do not even admit a mutual refinement, preventing any canonical or computable comparison.

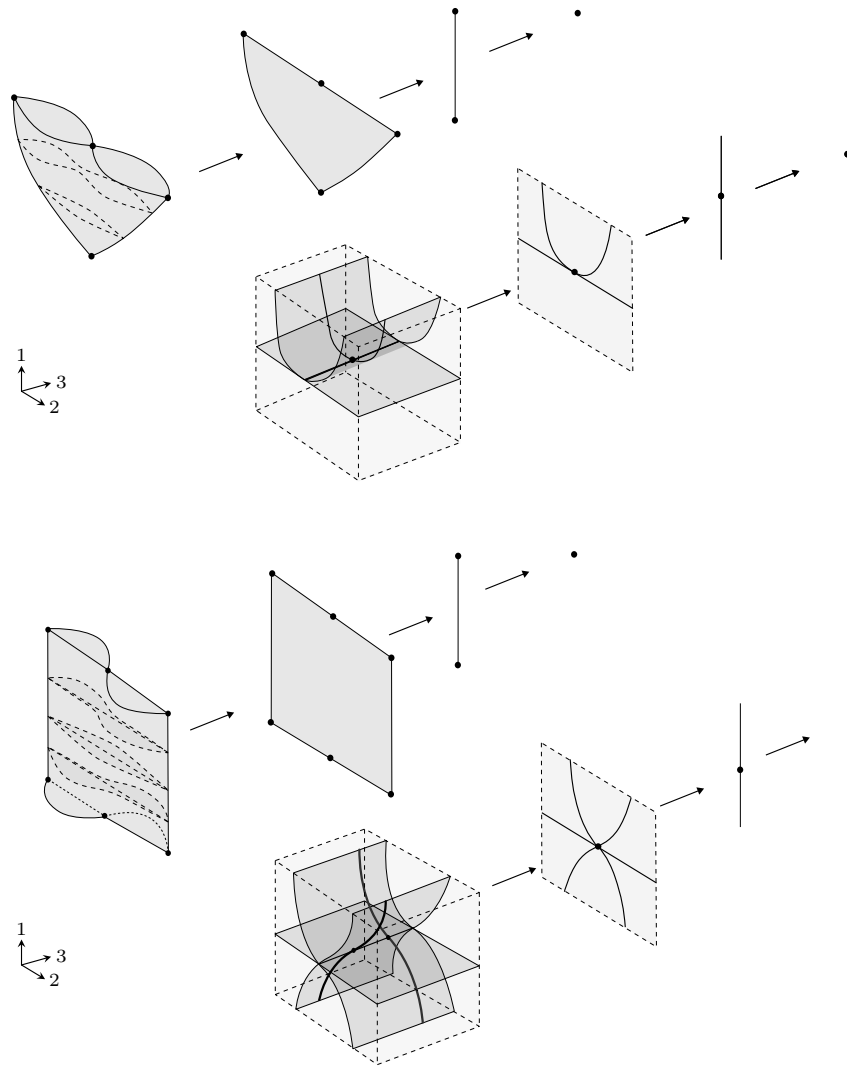

FIGURE I.6. Dualization of meshes.

THEOREM 9 (Coarsest meshes of tame stratifications; Thm. 5.2.23). *Any tame stratification has a unique refining mesh that is coarser than any other refining mesh.*

In Figure I.8 and Figure I.9 we depict the coarsest mesh for the third Reidemeister move and for the swallowtail singularity.

A tame stratification is refined by a mesh, and a mesh is combinatorialized by a truss; to complete the combinatorialization of tame stratifications, we translate the initial stratification into a stratified structure on the truss. A

11 : fwiw this was the location of the previous farthest cld-here

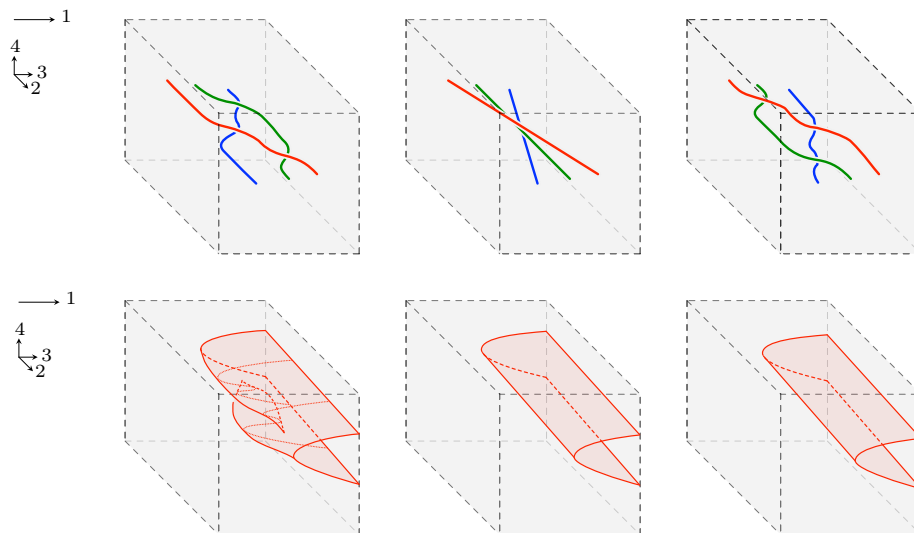

FIGURE I.7. Two tame stratifications of the 4-cube.

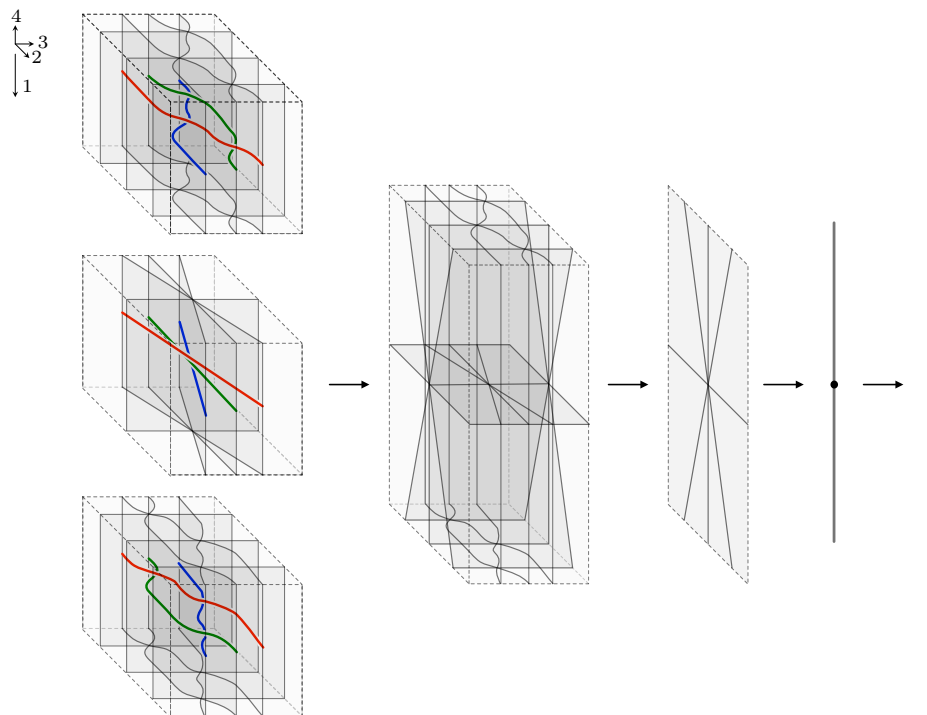

FIGURE I.8. The coarsest mesh refining the third Reidemeister move.

‘stratified poset’ is a poset together with a ‘stratification map’ to another poset (encoding the set of strata and the combinatorial entrance paths between them); a ‘stratified truss’ is a truss together with a stratification of its

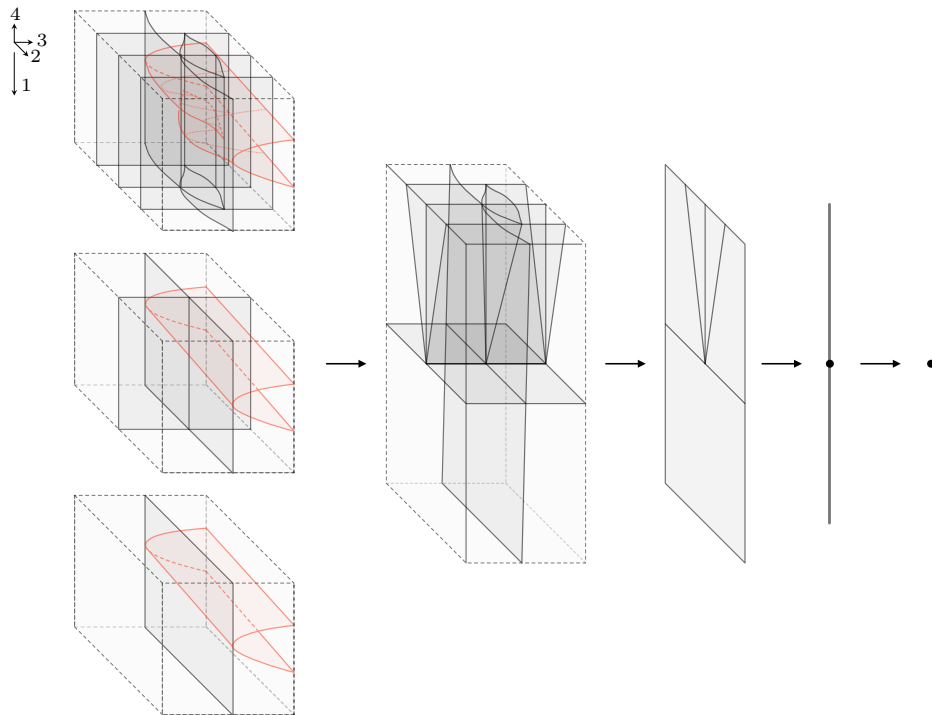

FIGURE I.9. The coarsest mesh refining the swallowtail singularity.

total poset. Furthermore, a stratified truss is ‘normalized’ if it cannot be simplified while preserving the stratification; this property of being normalized corresponds to a mesh being maximally coarsened while still refining a given stratification.

THEOREM 10 (Classification of tame stratifications; Thm. 5.1.23). *Framed stratified homeomorphism classes of tame stratifications are in bijective correspondence with isomorphism classes of normalized stratified trusses.*

In Figure I.10 we illustrate a tame stratification, its coarsest refining mesh, and the corresponding normalized stratified truss; the stratification on the truss records which strata of the mesh assemble into each stratum of the initial tame stratification.

Tame stratifications are intrinsically topological structures, considered up to homeomorphism, while stratified trusses are intrinsically combinatorial or piecewise linear structures, considered up to combinatorial or piecewise linear equivalence—the classification of framed stratifications by stratified trusses thus provides a faithful bridge between the topological and piecewise linear contexts. Recall the classical, false Hauptvermutung, that homeomorphic simplicial complexes are piecewise linear homeomorphic. The failure of correspondence between the topological and the piecewise linear remains even for subspaces (or substratifications) of euclidean space: given two piecewise

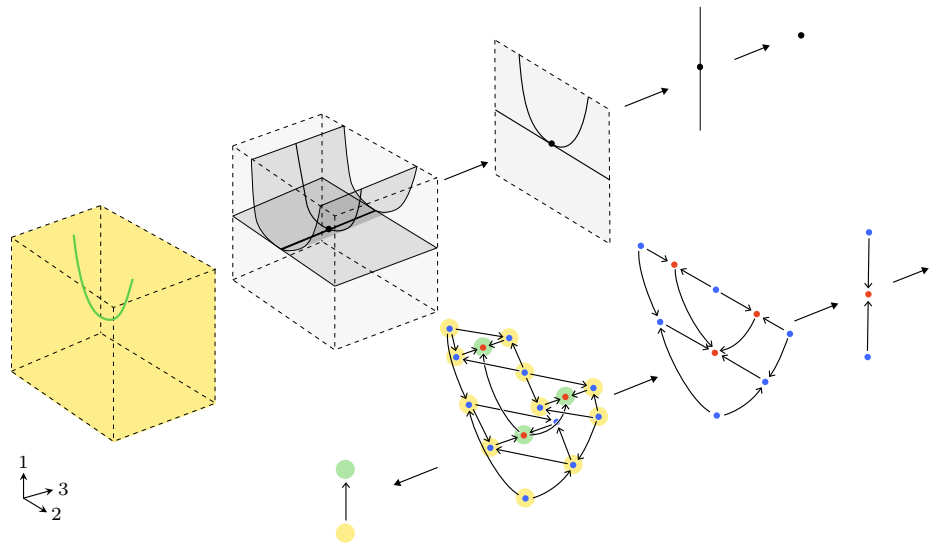

FIGURE I.10. A tame stratification, its coarsest mesh, and its normalized stratified truss.

linear embedded triangulated spaces in euclidean space that are ambient homeomorphic, they need not be ambient piecewise linear homeomorphic. By contrast, in the framed setting we will have a tight correspondence between the topological and piecewise linear, as follows.

THEOREM 11 (Framed Hauptvermutung; Thm. 5.1.27). *Any framed stratified homeomorphism between polyhedral stratifications is (framed stratified) homotopic to a framed stratified piecewise linear homeomorphism.*

Having a combinatorial or piecewise linear handle on tame stratifications, via stratified trusses, resolve the fundamental decidability problem for framed stratified homeomorphism.

THEOREM 12 (Decidability of framed stratified homeomorphism; Thm. 5.1.30). *Given two tame stratifications, one can algorithmically decide whether they are framed stratified homeomorphic.*

More generally, for n -directed acyclic graphs (i.e. framed regular cell complexes admitting a framed realization to, but not necessarily into, euclidean space), the problem of framed homeomorphism is likewise decidable.

THEOREM 13 (Decidability of framed homeomorphism of n -DAGs; Thm. 5.1.31). *Given two n -directed acyclic graphs, one can algorithmically decide whether they are framed homeomorphic.*

12 : This is an exact replica of the maintext theorem — so are the next two. Could compress to ‘polyhedral stratifications that are framed stratified homeomorphic are also framed stratified piecewise linear homeomorphic’ (or similar).

13 : Removed ref to the o-minimal comparison remark. If we feel that should be mentioned in the intro, consider. But we do already mention o-minimal earlier.

14 : What’s the pause logic in the summary section?

15 : I think any plausibility story for these goes in the Outlook. But if there is something very short to say here, maybe could add. Some stuff commented out.

16 : Reconsider transition here. Possibly go to transversely

One may hope to extend the above computable combinatorialization of framed topological phenomena to framed *smooth* phenomena. A ‘tame tangle’ is an embedding of a manifold into euclidean space, whose image can be refined by a tame stratification all of whose strata are generically positioned. Every tame tangle has an associated combinatorial ‘tangle truss’, given by an induced stratification of the normalized stratified truss classifying the coarsest refining tame stratification.

CONJECTURE 14 (Framed combinatorial equivalence implies diffeomorphism; Conj. 5.4.37). *When two compact smooth manifolds are smoothly embedded in euclidean space, defining tame tangles with isomorphic associated tangle trusses, there is a diffeomorphism between them.*

CONJECTURE 15 (Smooth embedded manifolds are isotopic to tame tangles; Conj. 5.4.38). *Any smooth embedding of a compact smooth manifold into euclidean space is isotopic to a smooth tame tangle.*

Because tame stratifications can be faithfully combinatorialized as stratified trusses, these conjectures together would provide the first faithful combinatorial representation of smooth structures on manifolds.

I.4. Overview

See Figure I.11 for a diagrammatic outline of the core concepts and connections, and Figure I.12 for a visual guide to the chapter dependencies.

Outline. Chapter 1 introduces framed combinatorial structures. The first such structure, ‘framed simplices’, is a combinatorial analog of classical framed vector spaces. A ‘framed simplicial complex’ will be a collection of compatibly framed simplices. After recalling the classical combinatorial-topological definition of regular cell complexes, we then further generalize framed simplicial complexes to ‘framed regular cell complexes’.

In Chapter 2, we develop our fundamental combinatorial notion of ‘trusses’, as certain iterated constructible bundles of posets. This development begins with ‘1-trusses’, which are framed fence posets, morphisms between them called ‘1-truss bordisms’, and families of them called ‘1-truss bundles’. 1-truss bundles over simplices turn out to have an unexpected total order on the top-dimensional simplices in their total posets, and this leads to a crucial method of ‘truss induction’. Finally, we describe ‘ n -trusses’, as iterated 1-truss bundles, their corresponding ‘ n -truss bordisms’ and ‘ n -truss bundles’, and their elementary constituents ‘ n -truss blocks’.

Chapter 3 proves the equivalence of the category of truss blocks and the category of framed regular cells, and more generally the equivalence of the category of regular presheaves on truss blocks and the category of framed regular cell complexes, as stated in Theorem 2 and Theorem 3 above. Truss blocks are translated into framed regular cells by an appropriate combinatorial ‘gradient’ functor; the converse functor, termed ‘integration’,

17 : May want to revisit this lightning introduction of the terms involved.

18 : Can we stand by that ‘first’? Gap between that and the more understated end of 5.4.

19 : Review and revise the meaning of the different arrow types (eg into). Add new arrow types.

20 : Remove bold in overview diag

21 : Slightly annoying that they are all section refs except C3 times 3

22 : Add missing sections (1.2, 2.1, 2.2)

23 : Add missing notions (framed simplicial complexes etc)

24 : Consider logic of overall placement in dependency figure

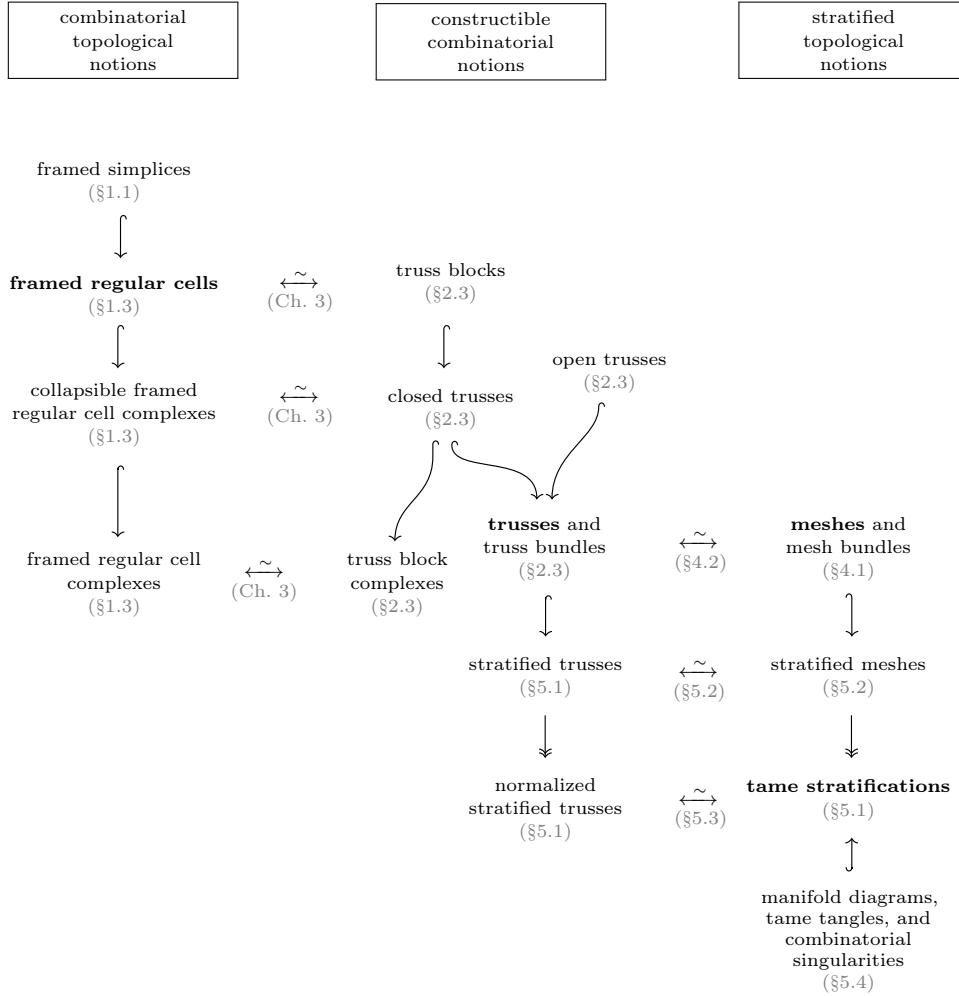

FIGURE I.11. Overview of concepts and connections.

entails the more technical construction of a tower of 1-truss bundles from the framing information on the regular cell.

In Chapter 4, we introduce our fundamental stratified topological notion of ‘meshes’, as certain iterated constructible bundles of stratified manifolds. From the outset, meshes appear as a topological analog of the combinatorial structure of trusses, and the notions of ‘1-mesh’, ‘1-mesh bundle’, and ‘ n -mesh’ parallel the corresponding truss notions. Indeed, we prove, as claimed in Theorem 5, that the topological category of meshes is weakly equivalent to the discrete category of trusses; one direction constructs a ‘fundamental truss’, which combinatorially encodes a mesh, and the other direction produces a ‘mesh realization’, which geometrically realizes a truss. This fundamental translation allows us to establish the classification of subdivisions of framed regular cells (Theorem 6) and the self-duality of meshes (Corollary 7).

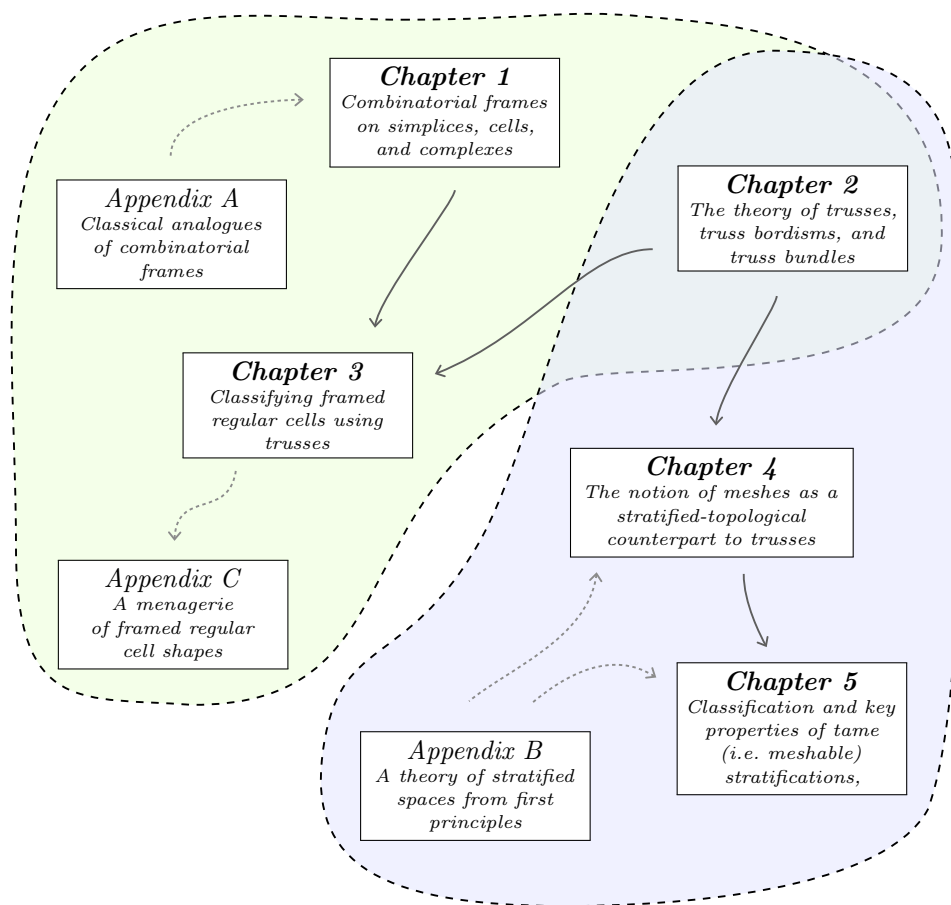

FIGURE I.12. Overview of dependencies.

Finally, [Chapter 5](#) radically broadens the class of stratifications under investigation, introducing ‘tame stratifications’ as those stratifications that admit a mesh refinement. The core work of the chapter is the proof that every tame stratification has a coarsest refining mesh, as claimed in [Theorem 9](#). We leverage that result to establish the combinatorial classification of tame stratifications in terms of normalized stratified trusses ([Theorem 10](#)). We then bridge the topological–piecewise linear chasm, proving the framed Hauptvermutung ([Theorem 11](#)) that any framed stratified homeomorphism between polyhedral stratifications is (framed stratified) homotopic to a framed stratified piecewise linear one. As applications, we establish the decidability of framed stratified homeomorphism ([Theorem 12](#)) and, for the broader class of n -directed acyclic graphs, the existence of coarsest cell structures and the decidability of framed homeomorphism. In the final portion of the chapter, we introduce manifold diagrams and tame tangles, outline a program for the

study of tangle singularities and isotopies, and conjecture that the combinatorial classification of tame tangles faithfully encodes smooth structures (Conjecture 14 and Conjecture 15).

Chapter A provides a detailed discussion of classical linear frames, corresponding notions of indframes and proframes, generalizations to partial and embedded frames, and affine analogs of these structures. Chapter B reviews and elaborates various elementary notions from stratified topology, including the construction of fundamental posets and higher categories of stratifications. Chapter C provides a menagerie of framed regular cells in low dimensions, illustrating the range of familiar, curious, novel, and exotic shapes that can arise.

Guide. Contents of this research book are organized in a largely linear fashion. However, this linearity hides that there are, in fact, two intertwining conceptual tracks: one is the ‘*classical* combinatorial structures’ track starting in Chapter 1, the other the ‘*constructible* combinatorial structures’ track starting in Chapter 2. The former builds directly on familiar classical notions, such as simplices and regular cells, introducing framings as an additional structure on those. This perspective will be especially helpful to the reader who has had some previous exposure to classical combinatorial topology. The latter chapter makes no direct contact with any classical notions; instead, it defines and explores a new notion of constructible combinatorial stratified line bundles. The equivalence of the two perspectives is proven in Chapter 3, though the (at times technical) proofs should not distract the reader from the useful core intuitions relating the perspectives developed earlier.

Both Chapter 1 and Chapter 2 introduce new combinatorial notions and are, therefore, definition and example driven chapters by design that are relatively light on theorems and proofs. This is distinctly different from the flavor of Chapter 4 and Chapter 5, which focus on putting the earlier definitional frameworks to use. Together, these chapters contain most of this book’s ‘headline results’. In both, the constructible perspective will be more important than the classical perspective on framed combinatorial structures. Therefore, to get to these chapters, a reading of Chapter 1 and Chapter 3 is not strictly necessary (at least for the majority of the discussed results).

An attempt is made, despite this book notably developing a *new area* of research rather than acting as a reference to or expansion of an existing one, to keep contents as self-contained as possible. In particular, the book should be readable by any reader with basic knowledge of simplicial topology and category theory. Additional topics are reviewed in the appendices (in particular Chapter B, which provides an introduction to stratified topology): note that all three appendices are designed mostly independently of the main text and can thus be read separately or in parallel as the reader sees fit. Moreover, key terms and symbols are indexed in the backmatter with references to the relevant environments where they are defined. Finally, we

25 : Reconsider the second half of the AppB sentence – something more representative?

26 : Consider number of occurrences of ‘book’ here.

27 : Consider compressing this. Consider adding explicit paths.

28 : The two bubbles aren’t really distinguished by classical v constructible, since only C1 is classical. Rather the two bubbles are the natural subsets that are logically self-contained

remark that sections containing technical proofs and constructions that can be safely skipped are marked with the symbol ✱ .

I.5. Outlook

We briefly summarize our immediate outlook for framed combinatorial topology beyond the present book; a more detailed discussion of these future directions appears in the final [Section 5.4](#).

Tame stratifications are already highly, if implicitly, structured by their canonical mesh refinements and the relation of that refinement to the ambient frame on euclidean space. However, the stratification itself need not be in any sort of generic or transverse relation to the ambient frame; for certain theoretical and computational purposes, it is essential to restrict attention to appropriately transverse stratifications. We can define and detect a transverse stratification in purely topological, as opposed to smooth, terms, by insisting that every stratum project by a local homeomorphism to the corresponding stage of the ambient euclidean proframe. We dub these transverse stratifications *manifold diagrams*; indeed our definition provides finally a formal generalization of string diagrams to all higher dimensions. This notion of manifold diagrams is as satisfying as one could hope: first, because of the combinatorializability of tame stratifications, manifold diagrams are also completely combinatorializable, into an appropriate notion of transverse stratified trusses; second, using the dualization of meshes, manifold diagrams naturally dualize to a notion of cellular diagrams that formalizes arbitrary composability structures in higher categories.

Leveraging the theory of manifold diagrams, we can identify the combinatorially tractable class of *tame tangles*, namely those embeddings of manifolds in euclidean space that admit refinements to manifold diagrams; the transversality of the strata of the refining manifold diagram ensures that the embedded manifold is generically positioned with respect to the ambient framing. Of course we expect any embedding of a manifold has an arbitrarily small deformation to a tame tangle, and so nothing is lost by excluding more wild configurations. Our combinatorial encoding of (tame) tangles immediately provides a novel computational toolkit: we can stratify the space of tangles by algorithmically computable local or global complexity measures, and formalize computable notions of tangle perturbation, simplification, and suitable stability. Having a robust algorithmic approach to tangles is already novel by dimension 4, but indeed our definitions and tools apply in all dimensions and all codimensions. The divergence of our theory from the classical perspective becomes especially stark in higher dimensions. A sufficiently small open neighborhood in a tangle is called a *tangle singularity*, and one would hope to identify classes of singularities that are universal, in the sense that any tangle may be assembled from them, at least up to perturbation. One traditional view has been that any such smooth singularity classification becomes profoundly unmanageable as the dimension increases:

Mention other back-matter eg glossary, symbol list, list of figures, etc [not needed here imo]

29 : Does proframe arise in the Overview sufficiently to use as it is in the Outlook? Maybe.

first arise uncountable continuous moduli of distinct singularity types, then the moduli space of singularities itself becomes infinite dimensional, and generally demons abound. By contrast, we foresee a natural equivalence relation on tangle singularities for which there is a countable, algorithmically computable classification in all dimensions.

That context of manifold diagrams, tame tangles, and tangle singularities established, there arise various open questions and directions for investigation. For instance: which measures of complexity yield a satisfying taxonomy of unsimplifiable singularities; which such unsimplifiable singularities are also imperturbable; is the class of imperturbable unsimplifiable singularities suitably universal? We expect that the set of isomorphism classes of imperturbable unsimplifiable singularities in any fixed dimension is finite, but the structure of this classification remains mysterious as the dimension grows. Complementary to local tangle singularities are the *tangle isotopies*, which are singularity-free disconnected tangles encoding the ways manifolds can pass by one another at a distance in euclidean space. As there are singularities distinguished by being appropriately unsimplifiable, similarly there ought to be isotopies distinguished, for instance, by being appropriately irreducible, and we may undertake an analogous taxonomic program for such isotopies. Again, we expect that the set of isomorphism classes of imperturbable irreducible isotopies in any fixed dimension is finite, but a precise classification remains unknown even in relatively low dimensions.

Given a sufficiently generic k -dimensional tangle M^k in euclidean space \mathbb{R}^n , the composite map $M^k \hookrightarrow \mathbb{R}^n \rightarrow \mathbb{R}^m$ (where the last map is the standard projection in the canonical proframe of euclidean space) should be a prototypical ‘ m -Morse function’, in the sense that all its local singularities and global isotopies would be taken from a prescribed catalog of elementary types. We may further ask for the development of a direct definition of m -Morse functions (without reference to tangle embeddings), which retains the combinatorial and computational flavor of our manifold diagrams and tame tangles, and therefore admits a tractable classification and attendant application to manifold topology. We expect not only that such a combinatorial higher Morse theory exists, but that the resulting combinatorial invariants detect all smooth structures. The realization of such an expectation depends, most likely, on the validity of the preceding conjectures about framed combinatorial equivalence and tame genericity—indeed those together entail that every combinatorially tame tangle has a canonical smooth structure and that every smooth manifold has such a combinatorially tame representation.

ACKNOWLEDGMENTS

We thank André Henriques, Vidit Nanda, Emily Riehl, Mike Shulman, Hiro Tanaka, Kevin Walker, and Mahmoud Zeinalian for helpful and clarifying conversations; Jan Steinebrunner, Filippos Sytilidis, and Christoph Weis for questions and feedback during a preliminary reading group on this material; Manuel Araújo and Jim Davis for comments and corrections on a draft of this book; and David Ayala and Dominic Verity for their encouragement and guidance. We are grateful to David Reutter and Jamie Vicary for extensive and inspiring discussions concerning combinatorial approaches to homotopy theory. We thank Ciprian Manolescu and Mark Powell for technical input regarding classical combinatorial topology.

Throughout the research and writing of this book, we were both partially supported by the EPSRC grant EP/S018883/1, “Higher algebra and quantum protocols”, which was conceived and prepared in collaboration with Jamie Vicary and David Reutter. We thank the Stanford Institute for Theoretical Physics for hosting us for an extended research visit during which some preliminary aspects of this work were envisioned. CLD was partially supported by a research professorship in the MSRI programs “Quantum symmetries” and “Higher categories and categorification” in the spring of 2020, and we both benefited from the hospitality of MSRI that semester, during which core elements of this work took shape. CD would like to thank the teams at TypeDB and Symbolica AI and CC for their support and many enriching discussions during the completion of this project.

30 : Add Sergei and AMS folks

31 : Add MPIM
Add TypeDB and Symbolica

32 : Add Filippos and anyone else who proofread – Yuhang, Glen? Manuel?

1 : Add Lukas Heide-
mann

CHAPTER 1

Framed combinatorial structures

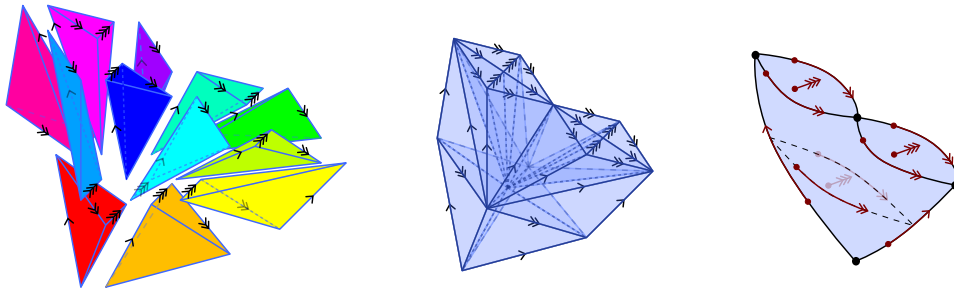

In this chapter, we develop a theory of framed simplices, framed simplicial complexes, and framed regular cell complexes. A framing of a simplex is an ordered basis of its simplicial vectors; a framing of a simplicial complex is a compatible collection of framings of its simplices; and a framing of a regular cell complex is similarly a compatible collection of framings of its cells. In Chapter 2, we will introduce trusses as constructible combinatorial bundles of framed fence posets, and in Chapter 3, we will prove that trusses provide a tractable, computable combinatorial classification of framed regular cell complexes.

We begin this chapter, in Section 1.1, by detailing a systematic and guiding analogy between frame structures in linear algebra and in affine combinatorics, and accordingly defining framed simplices and their framed maps. We then, in Section 1.2, introduce framings on simplicial complexes, as compatible systems of framings of the constituent simplices, and describe the condition of collapsibility for framed simplicial complexes. Finally, in Section 1.3, we define framed regular cell complexes, as combinatorial regular cell complexes with a framing of an underlying simplicial complex that is collapsible on each cell.

1.1. Framed simplices

The vectors in a vector space admit linear combination. A basis is a collection of vectors from which all others may be obtained by such combinations. A framed vector space is a vector space together with a basis of vectors and a chosen order on that basis. A guiding premise in the conceptual adaptation of frames from linear algebra into the combinatorics of simplices is that vectors in a vector space become directed edges in a simplex. However, simplices are spanned by their vertices and have no distinguished origin; simplicial vectors (i.e. directed edges) may begin at any vertex and so have an affine character. Though linear combination is no longer available for affine vectors, it can be replaced by end-to-end affine composition. A basis of a simplex then is a collection of simplicial vectors from which all others may be obtained (up to edge direction) by iterated composition. A *framed simplex* is a simplex together with a basis of simplicial vectors and a chosen order on that basis.

A framed m -dimensional vector space is canonically isomorphic to the standard framed vector space \mathbb{R}^m , by mapping the basis vectors in order to the standard frame vectors $\{e_1, e_2, \dots, e_m\}$. An m -simplex with a basis is already canonically isomorphic to the standard simplex $[m] = (0 \rightarrow 1 \rightarrow \dots \rightarrow m)$, by mapping the basis simplicial vectors in composable order to the standard directed vectors $\{(0 \rightarrow 1), (1 \rightarrow 2), \dots, (m-1 \rightarrow m)\}$. The choice of an order on such a simplicial basis provides crucial additional structure and is the technical locus of the essential disanalogy: in each dimension, there is a unique framed vector space but there are various distinct framed simplices. Algebraically, this contrast arises simply because linear combination is commutative while affine composition is not commutative; geometrically, the disparity emerges because the standard basis vectors form a unique linear configuration, whereas there are several affine constellations of those same standard vectors. For instance, considering the standard vectors e_1 and e_2 , there is an affine arrangement in which e_1 may be postcomposed with e_2 , and also an arrangement in which e_2 may be postcomposed with e_1 ; those arrangements and the distinct framed 2-simplices they span are illustrated on the left in Figure 1.1. Similarly, the three standard basis vectors e_1 , e_2 , and e_3 admit six affine concatenations, spanning the different types of framed 3-simplices, as illustrated on the right of that figure. In general, the combinatorics of framed simplices will allow and account for all possible such affine realizations.

OUTLINE. In Section 1.1.1, we develop a motivational analogy between various classical notions in linear algebra and counterparts in affine combinatorics; guided by this rough correspondence, we define frames on simplices, and more generally partial frames and embedded frames on simplices. In Section 1.1.2, we describe the restriction of embedded frames to simplicial faces, and characterize framed maps of framed simplices.

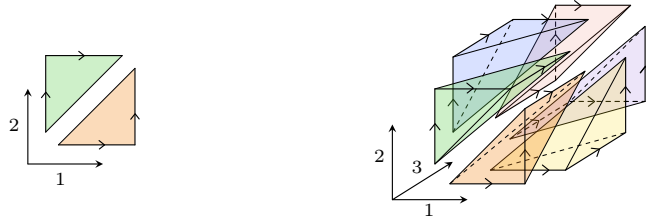

FIGURE 1.1. Distinct framed simplices spanned by the same standard frame vectors.

1.1.1. Frames, partial frames, and embedded frames.

SYNOPSIS. We present an extended motivational analogy between structures in linear algebra and in affine simplicial combinatorics. We introduce the notion of a frame of a simplex, which may be considered an ordered collection of all the spine vectors of the simplex. We then describe a partial frame of a simplex, which may be characterized as an ordered collection of some of the spine vectors. Finally, we define an embedded frame of a simplex, which may interpreted as an ordered collection of all the spine vectors interleaved with affine null vectors.

TERMINOLOGY 1.1.1 (Combinatorial simplices). An ‘ordered m -simplex’ is a totally ordered set with $m + 1$ elements. An ‘unordered m -simplex’, also called simply an ‘ m -simplex’, is a set with $m + 1$ elements. —

NOTATION 1.1.2 (Category of ordered simplices). We will denote the category of ordered simplices by Δ ; its objects are the ordered simplices, and its morphisms are the order-preserving functions (referred to as ‘simplicial maps’ or simply ‘maps’). —

NOTATION 1.1.3 (Category of unordered simplices). We will denote the category of unordered simplices by $\underline{\Delta}$; its objects are the unordered simplices and its morphisms are all functions (referred to also as ‘simplicial maps’ or simply ‘maps’). —

TERMINOLOGY 1.1.4 (Unordering ordered simplices). The ‘unordering functor’ $(-)^{\text{un}} : \Delta \rightarrow \underline{\Delta}$ forgets the order of ordered simplices. —

TERMINOLOGY 1.1.5 (Face maps and degeneracy maps). A ‘face map’ $S \hookrightarrow T$ is an injective map of (ordered or unordered) simplices. A ‘degeneracy map’ $S \twoheadrightarrow T$ is a surjective map of (ordered or unordered) simplices. —

NOTATION 1.1.6 (Maps between ordered and unordered simplices). For an ordered simplex S and an unordered simplex T , maps $S \rightarrow T$ and $T \rightarrow S$ refer implicitly to maps of unordered simplices $S^{\text{un}} \rightarrow T$ and $T \rightarrow S^{\text{un}}$. —

TERMINOLOGY 1.1.7 (Standard ordered simplex). The ‘standard ordered m -simplex’ $[m]$ is the totally ordered set $(0 < 1 < \dots < m)$; considering

totally as partially ordered sets, and posets as categories, this simplex is the category $(0 \rightarrow 1 \rightarrow \cdots \rightarrow m)$. \square

We will usually refer to the standard ordered m -simplex $[m]$ as ‘the standard m -simplex’ $[m]$ or simply as ‘the m -simplex’ $[m]$.¹ Every ordered m -simplex S is canonically isomorphic to the standard m -simplex $[m]$.

NOTATION 1.1.8 (The skeleton of standard simplices). We denote the skeleton of the category Δ containing only the standard simplices $[m]$, for $m \in \mathbb{N}$, also (abusing notation) by Δ . \square

TERMINOLOGY 1.1.9 (Unordered standard simplex). The ‘unordered standard m -simplex’ is the unordering $[m]^{\text{un}} = \{0, 1, \dots, m\}$ of the standard ordered simplex $[m] = (0 < 1 < \cdots < m)$. \square

TERMINOLOGY 1.1.10 (Sets of numerals). The ‘set of numerals’ or ‘numeral set’ \underline{m} is the ordered set $\{1 < 2 < \cdots < m\}$; a morphism of numeral sets is an order-preserving function. \square

1.1.1.1. The fundamental analogy. We describe a fundamental, though loose, analogy between certain notions in linear algebra and corresponding notions in affine simplicial combinatorics, which will motivate and guide our definitions of framed combinatorial structures. See [Chapter A](#) for recollections of the relevant linear and affine algebra background context.

Our primary and mantric correspondence is between the concept of an m -dimensional vector space V and the concept of an unordered m -simplex S . The standard vector space \mathbb{R}^m has its correlate being the standard simplex $[m]$. For a vector in a vector space, we have the analog being a ‘simplicial vector’ in a simplex, as follows.

TERMINOLOGY 1.1.11 (Simplicial vectors). A ‘simplicial vector’ (or just ‘vector’) V in an unordered simplex S is a map $v : [1] \rightarrow S$. A vector in an ordered simplex T is simply a vector in its unordering T^{un} ; whereas an ‘ordered vector’ v is an (order-preserving) map $v : [1] \rightarrow T$. In any of these cases, a vector is ‘nondegenerate’ when the map v is injective (so has image a directed edge); the vector is ‘degenerate’ (or ‘zero’) when by contrast it is constant (so has image a vertex). We will typically assume vectors are nondegenerate unless noted otherwise. \square

TERMINOLOGY 1.1.12 (Composites and linear combinations). Given two vectors $u : [1] \rightarrow S$ and $v : [1] \rightarrow S$ in an (ordered or unordered) simplex, which are composable in the sense that $u(1) = v(0)$, their ‘composite’ is the vector $w : [1] \rightarrow S$ with $w(0) = u(0)$ and $w(1) = v(1)$. Given a vector $v = (v(0) \rightarrow v(1))$, its ‘negative’ is the vector $-v = (v(1) \rightarrow v(0))$. A ‘linear combination’ is a vector obtained by iterated composition and negation. \square

¹Our terminological conventions then entail that ‘an m -simplex’ or ‘a simplex’ refers to an unordered simplex, while ‘the m -simplex’ or ‘the simplex $[m]$ ’ refers to an ordered simplex; this articular dependency is sufficiently convenient that we tolerate the potential confusion.

A basis of a vector space is a collection of vectors, from which all vectors may be obtained as linear combinations. Analogously, one might consider a basis of a simplex to be a collection of simplicial vectors, from which all (nondegenerate) simplicial vectors may be obtained as (iterated) linear combinations; however, we take the more restrictive perspective that a basis of a simplex is a collection of simplicial vectors, from which all others are obtained, up to negation, by (iterated) composition only. An ordered basis of a vector space is of course just a basis with any choice of order; a basis of a simplex by contrast has a canonical choice of order, namely the one in which the vectors are composable in the given order (so that all other vectors are obtained, up to negation, by composition without reordering). That notion of basis of a simplex with its canonical order may be formulated as a ‘directed spine’, as follows.

TERMINOLOGY 1.1.13 (Directed spine of an unordered simplex). A ‘directed spine’ of an unordered m -simplex is an ordered set of m nondegenerate vectors, such that the target vertex of each vector is the source vertex of the subsequent vector (when there is a subsequent vector), and such that the image of the spine covers every vertex of the simplex. A ‘spine vector’ of a simplex with a directed spine is simply one of the vectors in the directed spine. —

An ordered basis of a vector space amounts to an isomorphism from (or to) the standard vector space. Similarly, a directed spine of an unordered m -simplex S amounts to an isomorphism from (or to) the standard simplex $[m]$; such an isomorphism is of course also equivalent to a choice of ordering of the simplex.

NOTATION 1.1.14 (Directed spine of an ordered simplex). For an ordered m -simplex S , there is a preferred directed spine, denoted **spine** S , namely the series of vectors that traverses the vertices in order. —

REMARK 1.1.15 (The spine of the standard simplex). The directed spine **spine** $[m]$ of the standard simplex $[m]$ is of course the ordered set of vectors $((0 \rightarrow 1), (1 \rightarrow 2), \dots, (m-1 \rightarrow m))$. That spine may be canonically identified with the numeral set \underline{m} , by associating the spine vector $(i-1 \rightarrow i) \in \mathbf{spine}[m]$ with the numeral element $i \in \underline{m}$. —

In classical linear algebra, the concept of an ordered basis of a vector space is, of course, interchangeable with the concept of a frame of a vector space.² However, here there is crucial *disanalogy* between linear algebra and affine combinatorics: for a vector space, an ordered basis is a frame, whereas for a simplex, a directed spine will not, by itself, provide a frame. Recall from [Figure 1.1](#) that there are multiple distinct ‘framed simplices’ built out

²Initially, we will take the word ‘frame’ to entail a sense of linear independence, but later generalizations of the notion, both linear algebraic and affine combinatorial, will allow certain dependencies.

of the same basis vectors; indeed there are as many such simplices as there are orders on the already canonically ordered set of basis vectors. As that figure adumbrates and as described precisely later, the further information required for a frame on a simplex, beyond a directed spine, will be *an order on that spine*.

Classical linearly-independent frames can be generalized by allowing the frame to be partial, that is, not entirely spanning the vector space, or allowing the frame to be redundant, that is, spanning but with dependencies, or indeed allowing both partiality and redundancy at the same time. A convenient way of encoding a ‘partial frame’ on a vector space V is via an injection $V \hookrightarrow \mathbb{R}^k$; we may alternatively consider a partial frame as being witnessed by a projection $V \twoheadrightarrow \mathbb{R}^k$ which is split by the given injection. A convenient way of encoding a ‘redundant frame’ on a vector space V is via a projection $V \leftarrow \mathbb{R}^n$; we may alternatively consider a redundant frame as being witnessed by an injection $V \hookrightarrow \mathbb{R}^n$ which splits the given projection. Definitionally we will favor the split witness perspective, and our affine combinatorial notions will be analogs of the projection $V \twoheadrightarrow \mathbb{R}^k$ and the injection $V \hookrightarrow \mathbb{R}^n$. However, terminologically we preference the two injections $V \hookrightarrow \mathbb{R}^k$ and $V \hookrightarrow \mathbb{R}^n$, and so the affine combinatorial notions will be called ‘partial frames on simplices’ and ‘embedded frames on simplices’. The conceptual pushout of these two notions, called ‘embedded partial frames’ will be affine combinatorial analogs of general linear maps $V \hookrightarrow W \leftarrow \mathbb{R}^n$ as witnessed by the reciprocal composites $V \twoheadrightarrow W \hookrightarrow \mathbb{R}^n$.

To motivate and prepare for the notions of generalized frames in the affine combinatorial case, we will need simplicial analogs of the notions of projection and injection of vector spaces. Projections pose no difficulty and correspond to ordinary simplicial degeneracy maps. Such degeneracies admit a reasonable analog of linear kernels, as follows.

TERMINOLOGY 1.1.16 (Kernel). The ‘kernel’ $\ker(S \twoheadrightarrow T)$ of a degeneracy map $S \twoheadrightarrow T$ is the subset of the simplicial vectors in S that are mapped to zero vectors by the degeneracy. —

Note that a subset of simplicial vectors is the kernel of a degeneracy precisely when it is closed under linear combination.

The usual companions of simplicial degeneracy maps are simplicial face maps; however, simplicial face maps are decidedly insufficient as a combinatorial analog of vector space inclusions. Instead, we must adapt the notions of kernels, faces, and images to suitable ‘affine’ notions, as follows.

TERMINOLOGY 1.1.17 (Affine kernel). The ‘affine kernel’ $\ker^{\text{aff}}(S \twoheadrightarrow T)$ of a degeneracy $S \twoheadrightarrow T$ of ordered simplices is the subset of the spine vectors in spine S that are mapped to zero vectors by the degeneracy. —

For a degeneracy $S \twoheadrightarrow T$ of ordered simplices, the affine kernel is the subset of spine vectors in the kernel; conversely, the kernel is the closure under linear combination of the affine kernel. Note well that a kernel $\ker(S \twoheadrightarrow T)$ need

not form the vectors of any subsimplex of the simplex S . Similarly, the affine kernel $\ker^{\text{aff}}(S \twoheadrightarrow T)$ need not form the spine vectors of any subsimplex, and so need not in any sense span the image of a simplicial face map; indeed the vectors of the affine kernel may be uncomposably skew to one another and so in that sense have an ‘affine’ character.

The kernel of any linear projection is a subspace, and any subspace is the kernel of the quotient by that subspace. Analogously, the affine kernel of any simplicial degeneracy is a subset of the spine, and any subset of $\text{spine } S$ is the affine kernel of the degeneracy $S \twoheadrightarrow T$ that degenerates exactly that subset of spine vectors; that correspondence suggests the following notions.

TERMINOLOGY 1.1.18 (Affine face). An ‘affine face’ map $f : S \leftrightarrow T$ of ordered simplices is an ordered map $f : \text{spine } S \leftrightarrow \text{spine } T$ of the spines. —

TERMINOLOGY 1.1.19 (Affine image). The ‘affine image’ of an affine face map $f : S \leftrightarrow T$ of ordered simplices is the image $\text{im}^{\text{aff}}(f) := \text{im}(f : \text{spine } S \leftrightarrow \text{spine } T) \subset \text{spine } T$ in the spine of the target. —

TERMINOLOGY 1.1.20 (Affine cokernel). The ‘affine cokernel’ of an affine face map $f : S \leftrightarrow T$ of ordered simplices is the complement $\text{coker}^{\text{aff}}(f) = \text{spine } T \setminus \text{im}^{\text{aff}}(f) \subset \text{spine } T$ of the affine image in the spine of the target. —

REMARK 1.1.21 (Simplicial retraction). For any affine face map $f : S \leftrightarrow T$, there is a canonical simplicial degeneracy $S \leftarrow T : g$ whose affine kernel $\ker^{\text{aff}}(g)$ is the affine cokernel $\text{coker}^{\text{aff}}(f)$; i.e. the degeneracy map degenerates exactly those spine vectors that are not in the affine image of the affine face map. —

The notions of simplicial degeneracy and affine faces combine to a general notion of affine simplicial maps.

TERMINOLOGY 1.1.22 (Affine maps). An ‘affine map’ $S \rightarrow R$ from an unordered simplex S to an ordered simplex R is a sequence $S \twoheadrightarrow T \leftrightarrow R$ consisting of a degeneracy $S \twoheadrightarrow T$ from S to an ordered simplex T , and an affine face $T \leftrightarrow R$. —

We will allow the term ‘affine face’ and its notation $S \leftrightarrow R$ to also refer to an affine map of the form $S \cong T \leftrightarrow R$, where S is unordered and T and R are ordered simplices.

Note, from the earlier discussion, that a frame on an unordered m -simplex S can be described as an isomorphism $S \xrightarrow{\sim} [m]$ to the standard simplex (providing a directed spine of S) together with a choice of order on the spine of the standard simplex $[m]$ (providing, by the isomorphism, an order on the spine of S). Equipped with the affine simplicial combinatorial analogs of vector space projections, inclusions, and maps, namely degeneracies, affine faces, and affine maps, we can provide a compact preview of the simplicial notions of generalized frames, namely partial frames, embedded frames, and embedded partial frames on simplices.

- › A *partial* frame of an unordered simplex S will be a degeneracy $S \twoheadrightarrow [k]$ together with an order on the spine of the target simplex $[k]$.
- › An *embedded* frame of an unordered simplex S will be an affine face $S \hookrightarrow [n]$ (which corresponds to its canonical retraction $[n] \twoheadrightarrow S$) together with an order on the spine of the retraction target S .
- › An *embedded partial* frame of an unordered simplex S will be an affine map $S \twoheadrightarrow T \hookrightarrow [n]$ (whose affine face $T \hookrightarrow [n]$ corresponds to its canonical retraction $[n] \twoheadrightarrow T$) together with an order on the spine of the retraction target T .

The prelude analogy described so far, between elementary structures in linear algebra and in affine simplicial combinatorics, is displayed in [Figure 1.2](#). See [Chapter A](#) for a more detailed discussion of the relevant classical linear algebraic notions. Our primary notions of frames and generalized frames on simplices are detailed, with further explanation, examples, and illustration, over the whole of this first section. Frames, partial frames, and embedded frames on vector spaces and simplices are illustrated in [Figure 1.3](#), along with a preview of their generalizations to simplicial complexes and regular cells.

1.1.1.2. The definition of framed simplices. We introduce frames of simplices, as a combinatorial analog of frames of vector spaces. The role of frame vectors is assumed by spine vectors of a simplex. As a linear frame is an ordered set of its frame vectors, a simplicial frame will be an ordered collection of spine vectors.

DEFINITION 1.1.23 (Frame on the standard simplex). A **frame \mathcal{F} of the standard m -simplex $[m]$** is a bijection $\mathcal{F} : \text{spine}[m] \rightarrow \underline{m}$ from the set $\text{spine}[m]$ of spine vectors of the simplex to the set of numerals $\underline{m} = \{1, 2, \dots, m\}$. —

We may of course equivalently think of a frame \mathcal{F} in terms of the inverse function $\mathcal{F}^{-1} : \underline{m} \rightarrow \text{spine}[m]$ from the set of numerals to the spine, or more concretely as an ordered list (v_1, v_2, \dots, v_m) of spine vectors $v_i = \mathcal{F}^{-1}(i) \in \text{spine}[m]$ of the simplex. That is, a frame of the standard simplex is an order on the standard spine, as emphasized in [Figure 1.2](#) as the analog of the standard frame of the standard euclidean space.

A frame of a non-standard simplex, i.e. an unordered simplex, may then be specified by choosing a standardization together with a frame on that standardized simplex, as follows.

DEFINITION 1.1.24 (Frame on a simplex). A **frame of an unordered m -simplex S** is an isomorphism $S \cong [m]$ to the standard m -simplex $[m]$, together with a frame \mathcal{F} on that simplex $[m]$. —

We usually denote framed simplices by pairs $(S \cong [m], \mathcal{F})$; we may also keep the isomorphism $S \cong [m]$ implicit, and simply say that \mathcal{F} is a frame on S . Of course, the choice of isomorphism $S \cong [m]$ is the same as a choice of spine for S , and the order \mathcal{F} on the standard spine gives an order on the chosen

Linear algebra	Affine combinatorics
an m -dimensional vector space V	an unordered m -simplex S
a nonzero vector v in V	a directed edge v in S
the zero vector 0 in V	a vertex x in S
an ordered basis of V	a directed spine of S \equiv an isomorphism $S \xrightarrow{\sim} [m]$
a projection $V \twoheadrightarrow W$	a degeneracy $S \twoheadrightarrow T$
an injection $V \hookrightarrow W$	an affine face $S \hookrightarrow T$: a choice of directed spines of S and T and an inclusion of spine S into spine T
a map $V \twoheadrightarrow W \hookrightarrow U$	an affine map $S \twoheadrightarrow T \hookrightarrow R$
the standard vector space \mathbb{R}^m	the standard simplex $[m]$
the standard ordered basis of \mathbb{R}^m	the standard directed spine of $[m]$
\parallel	\nVdash
the standard frame of \mathbb{R}^m	the standard directed spine of $[m]$ <i>with an order on that spine</i>
a frame of \mathbb{R}^m	a directed spine of $[m]^{\text{un}}$ with an order on that spine
a frame of V : an isomorphism $V \xrightarrow{\sim} \mathbb{R}^m$	a frame of S : an isomorphism $S \xrightarrow{\sim} [m]$ with an order on the spine of $[m]$
a k -partial frame of V : an injection $V \hookrightarrow \mathbb{R}^k$ \rightsquigarrow a retracting <i>projection</i> $V \twoheadrightarrow \mathbb{R}^k$	a k -partial frame of S : a <i>degeneracy</i> $S \twoheadrightarrow [k]$ with an order on the spine of $[k]$
an n -redundant frame of V : a projection $V \leftarrow \mathbb{R}^n$ \rightsquigarrow a splitting <i>injection</i> $V \hookrightarrow \mathbb{R}^n$	an n -embedded frame of S : an <i>affine face</i> $S \hookrightarrow [n]$ and an order on the spine of S
an n -redundant partial frame of V : a map $V \hookrightarrow W \leftarrow \mathbb{R}^n$ \rightsquigarrow a reciprocal map $V \twoheadrightarrow W \hookrightarrow \mathbb{R}^n$	an n -embedded partial frame of S : an affine map $S \twoheadrightarrow T \hookrightarrow [n]$ and an order on the spine of T

FIGURE 1.2. The analogy between notions in linear algebra and notions in affine combinatorics.

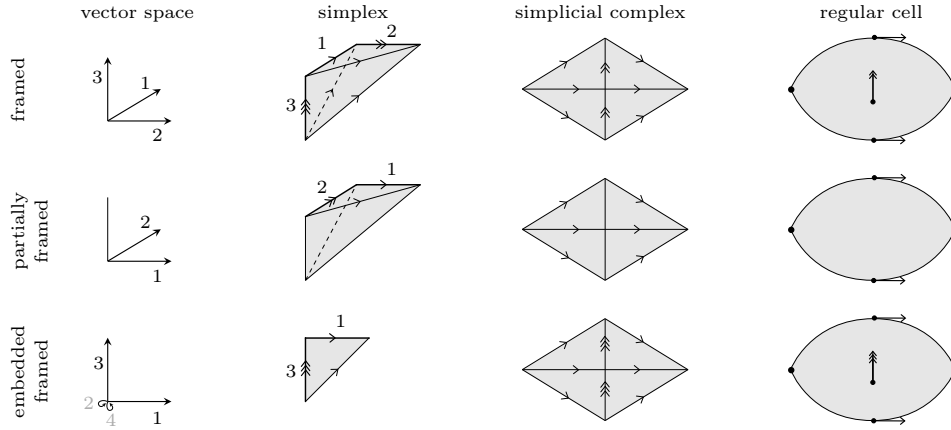

FIGURE 1.3. Frames in linear algebra and affine combinatorics.

spine for S ; we therefore often think of the frame of S as a choice of spine and order on that spine.

EXAMPLE 1.1.25 (Frames on simplices). In Figure 1.4, we depict a few framed m -simplices $(S \cong [m], \mathcal{F})$. The specified directed spine encodes an isomorphism $S \cong [m]$ (and we therefore do not distinguish between the illustrated simplex and the standard simplex). The frame $\mathcal{F} : \mathbf{spine}[m] \rightarrow \underline{m}$ is indicated in three different ways, as follows.

- > *Numeral labels*: the spine vector $v \in \mathbf{spine}[m]$ is labeled by its numeral value $\mathcal{F}(v) \in \underline{m}$.
- > *Arrowheads*: the numeral label of the spine vector is specified by the number of arrowheads along the simplicial vector.
- > *Coordinate frame*: the labeled spine vectors, thought of as vectors in the linear space spanned by the picture of the simplex, are translated so their sources are coincident, and the resulting labeled ‘coordinate frame’ is drawn in or near the simplex.

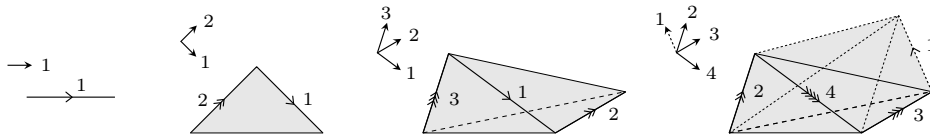

FIGURE 1.4. Framed simplices.

NOTATION 1.1.26 (Frame labels). In subsequent figures, we will primarily indicate the frame labels by the multi-arrowhead notation, though we sometimes also retain the coordinate frame and occasionally the numeral labels themselves for emphasis or clarity. (Note that in Figure 1.1, we depicted the

framed 2-simplices and framed 3-simplices using only the coordinate frame notation.) —

Beyond mere analogy, there is a precise relationship between framed simplices and framed vector spaces, in that there is a distinguished class of linear embeddings of the geometric realization of a framed simplex into standard framed euclidean space, namely those embeddings that preserve the frame structure in the following sense.

TERMINOLOGY 1.1.27 (Geometric simplices). The ‘geometric simplex’ $|S|$, of an unordered m -simplex S , is the convex hull of the set S in the free vector space $\mathbb{R}\langle S \rangle$. —

TERMINOLOGY 1.1.28 (The standard oriented components of euclidean space). For $1 \leq i \leq n$, consider the linear subspaces $\{0\}^i \times \mathbb{R}^{n-i}$ and $\{0\}^{i-1} \times \mathbb{R}^{n-i+1}$ in \mathbb{R}^n . The complement

$$\epsilon_i := (\{0\}^{i-1} \times \mathbb{R}^{n-i+1}) \setminus (\{0\}^i \times \mathbb{R}^{n-i})$$

has two components

$$\begin{aligned} \epsilon_i^- &:= \{0\}^{i-1} \times \mathbb{R}_{<0} \times \mathbb{R}^{n-i}, \\ \epsilon_i^+ &:= \{0\}^{i-1} \times \mathbb{R}_{>0} \times \mathbb{R}^{n-i}, \end{aligned}$$

which we refer to as the ‘ i th negative’ and ‘ i th positive standard component’ of \mathbb{R}^n , respectively. —

DEFINITION 1.1.29 (Framed realization of a framed simplex). A **framed realization** of a framed m -simplex $(S \cong [m], \mathcal{F})$, with frame vectors $v_i = \mathcal{F}^{-1}(i)$, is a linear embedding $r_{\mathcal{F}} : |S| \hookrightarrow \mathbb{R}^m$ of the geometric simplex $|S|$ into \mathbb{R}^m such that the translation vectors $\vec{v}_i := v_i(1) - v_i(0)$ are mapped into the i th positive standard component $\epsilon_i^+ \subset \mathbb{R}^m$, for all $i \in \underline{m}$.³ —

EXAMPLE 1.1.30 (Framed realization of a framed simplex). In [Figure 1.5](#) we illustrate framed realizations of the two framed 2-simplices, along with the resulting translation vectors \vec{v}_i based at the origin. See also again [Figure 1.1](#), where one has the images of one framed realization of each of the six framed 3-simplices. —

REMARK 1.1.31 (All framed simplices are realizable). Every framed m -simplex $([m], \mathcal{F})$ admits a framed realization $r_{\mathcal{F}} : |[m]| \hookrightarrow \mathbb{R}^m$. For instance, consider a map sending the vertex 0 to the origin in \mathbb{R}^m , i.e. $r_{\mathcal{F}}(0) := 0$, and each subsequent vertex k to $r_{\mathcal{F}}(k) := r_{\mathcal{F}}(k-1) + e_{\mathcal{F}((k-1 \rightarrow k))}$, where e_i is the i th standard basis vector of \mathbb{R}^m ; extend linearly to define a realization on the whole geometric simplex $|[m]|$. In such a realization, the spine of the simplex traces a lattice path from $(0, \dots, 0)$ to $(1, \dots, 1)$, with each spine vector incrementing one coordinate. (Up to an offset for readability, these are the realizations shown in [Figure 1.1](#).) —

³Technically, by ‘linear map’ $|S| \hookrightarrow \mathbb{R}^m$ we mean an ‘affine map’, as discussed in more detail in [Terminologies A.2.1](#) and [A.2.3](#).

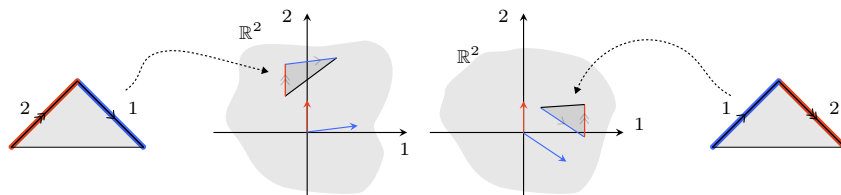

FIGURE 1.5. Framed realization of framed simplices.

1.1.1.3. Partial frames.

MOTIVATION 1.1.32 (Linear partial frames).⁴ A partial frame of a vector space is an injection $V \hookrightarrow \mathbb{R}^k$, or more concretely an ordered list of k linearly independent vectors; we consider a partial frame to be witnessed by a projection $V \twoheadrightarrow \mathbb{R}^k$ which is split by that injection.⁵ \square

A frame of a standard simplex, as described in the preceding section, is the assignment of a numeral frame label to each vector of the standard spine, or equivalently a bijection from the set of numerals to the set of spine vectors. We may consider instead a frame defined only on part of the spine, by the assignment of a numeral label to some of the spine vectors, or equivalently by an injection from a set of numerals to the spine set.

DEFINITION 1.1.33 (Partial frame on the standard simplex). A k -**partial frame of the standard m -simplex** $[m]$ is an injection $\mathbf{spine}[m] \hookrightarrow \underline{k}$ from the set of numerals $\underline{k} = \{1, 2, \dots, k\}$ to the spine of the simplex. \square

Recall the numeral set \underline{k} is canonically identified with the spine set $\mathbf{spine}[k]$; the partial frame may thus be considered as a frame on the simplex $[k]$ (i.e. a bijection $\mathbf{spine}[k] \cong \underline{k}$), together with a (necessarily ordered) affine face map $\mathbf{spine}[m] \hookrightarrow \mathbf{spine}[k]$. There is a unique simplicial degeneracy $[m] \twoheadrightarrow [k]$ whose affine kernel is the affine cokernel of that affine face map; therefore finally, the partial frame may equivalently be considered as a simplicial degeneracy $[m] \twoheadrightarrow [k]$ together with a frame on $[k]$.

A partial frame on a non-standard, i.e. an unordered simplex, may now be characterized similarly, as follows.

DEFINITION 1.1.34 (Partial frame on a simplex). A k -**partial frame on an unordered m -simplex** S is a degeneracy $S \twoheadrightarrow [k]$, together with a frame \mathcal{F} on that simplex $[k]$. \square

⁴Motivation paragraphs in this chapter recall the relevant linear algebraic notions, as context for the subsequent combinatorial definitions.

⁵In Section A.1.2, the projection split by the partial frame is referred to as a ‘partial trivialization’; here in the main text, we suppress the terminological distinction between frames and trivializations, and use ‘frame’ as the headline designation and lexical context for all such structures, whatever their variance, in both the linear algebraic and affine combinatorial cases.

Note that in an m -partial frame $(S \twoheadrightarrow [m], \mathcal{F})$ of an m -simplex S , the degeneracy $S \twoheadrightarrow [m]$ must be an isomorphism, and so m -partial frames on m -simplices are simply frames on m -simplices.

TERMINOLOGY 1.1.35 (Unframed subspace of a partially framed simplex). The ‘unframed subspace’ of a k -partially framed simplex $(S \twoheadrightarrow [k], \mathcal{F})$ is the kernel $\ker(S \twoheadrightarrow [k])$. Note that this ‘subspace’ is a subset of the nondegenerate simplicial vectors of the simplex S . —

EXAMPLE 1.1.36 (Partial frames on simplices). In Figure 1.6 we illustrate the two distinct 1-partially framed 2-simplices, and the three distinct 1-partially framed 3-simplices. Similarly, in Figure 1.7 we illustrate three of the six distinct 2-partial framings of the 3-simplex; the other three are obtained by exchanging all the 1 and 2 frame labels. We depict the degeneracies $S \twoheadrightarrow [k]$ by highlighting their unframed subspace (in green) and illustrate the target framed simplices $([k], \mathcal{F})$ as in Example 1.1.25. Note that the partial frame may also be recorded by labeling a vector v in S with $i \in \underline{k}$ (or with that many arrowheads) whenever its image $w := (S \twoheadrightarrow [k])(v) \in \mathbf{spine}[k]$ has frame label $\mathcal{F}(w) = i$. —

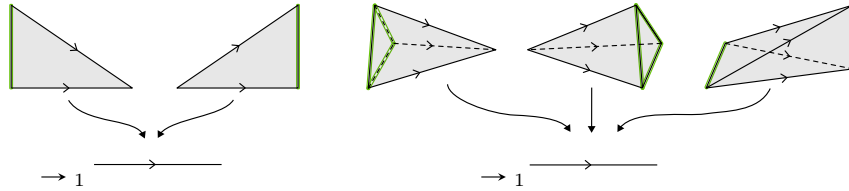

FIGURE 1.6. The 1-partially framed 2-simplices and 3-simplices.

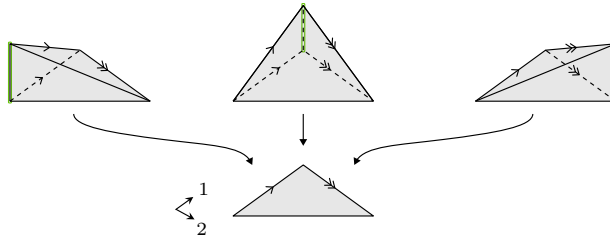

FIGURE 1.7. Half of the 2-partially framed 3-simplices.

A linear map of a partially framed simplex to euclidean space may preserve the frame structure in the following sense.

DEFINITION 1.1.37 (Framed realization of a partially framed simplex). Consider a k -partially framed m -simplex $(S \twoheadrightarrow [k], \mathcal{F})$, with unframed subspace $U := \ker(S \twoheadrightarrow [k])$. A **framed realization** of the partially framed simplex $(S \twoheadrightarrow [k], \mathcal{F})$ is a linear map $r_{\mathcal{F}} : |S| \rightarrow \mathbb{R}^k$ such that:

- › for all $v \notin U$ with image $w := (S \twoheadrightarrow [k])(v) \in \text{spine}[k]$ and $\mathcal{F}(w) = i$, the translation vector $\vec{v} := v(1) - v(0)$ is mapped into the i th positive standard component $\epsilon_i^+ \subset \mathbb{R}^k$, and
- › for all $v \in U$, the translation vector \vec{v} is mapped to $0 \in \mathbb{R}^k$. —

EXAMPLE 1.1.38 (Framed realization of partially framed simplices). In Figure 1.8 we illustrate framed realizations of a 1-partially framed 2-simplex and of a 2-partially framed 3-simplex. —

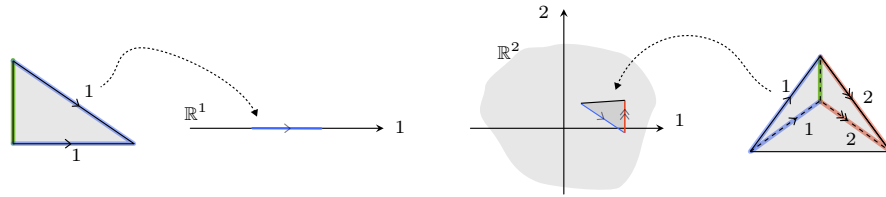

FIGURE 1.8. Framed realization of partially framed simplices.

1.1.1.4. Embedded frames.

MOTIVATION 1.1.39 (Linear redundant and embedded frames). A redundant frame on an m -dimensional vector space V is a projection $V \leftarrow \mathbb{R}^n$, or more concretely an ordered list of n vectors spanning V ; we consider a redundant frame to be witnessed by an injection $V \hookrightarrow \mathbb{R}^n$ which splits that projection.⁶ The information contained in the redundant frame may be compressed somewhat: from the ordered list of n vectors, set to zero those vectors that are in the span of the preceding vectors; the resulting ordered list of n vectors, exactly m of which are nonzero, and the nonzero vectors of which are linearly independent, is called an embedded frame of the vector space. —

As before, a frame of a standard m -simplex is an assignment of a numeral frame label in $\underline{m} = \{1, 2, \dots, m\}$ to each vector of the standard spine $\text{spine}[m]$, or equivalently a bijection from that spine to that numeral set. We may instead consider a kind of frame defined by the assignment, to spine vectors, of frame labels in \underline{n} , for $n > m$, or equivalently by an injection from the spine to a numeral set.

DEFINITION 1.1.40 (Embedded frame on the standard simplex). An n -embedded frame \mathcal{F} of the standard m -simplex $[m]$ is an injection $\mathcal{F} : \text{spine}[m] \hookrightarrow \underline{n}$ from the spine of the simplex to the set of numerals $\underline{n} = \{1, 2, \dots, n\}$. —

⁶In Section A.1.2, the injection splitting the redundant frame is referred to as an ‘embedded trivialization’, but here, as in the partial case, we elide the difference between frames and trivializations.

We may reconsider an n -embedded frame $\mathcal{F} : \mathbf{spine}[m] \hookrightarrow \underline{n}$ in terms of the partial inverse function $\mathcal{F}^{-1} : \underline{n} \rightarrow \mathbf{spine}[m]_+$ from the set of numerals to the ‘augmented spine’ $\mathbf{spine}[m]_+ := \mathbf{spine}[m] \sqcup \{0\}$ (i.e. the function \mathcal{F}^{-1} inverting \mathcal{F} on its image and sending the complement of that image to 0). Furthermore, that partial inverse function may be tangibly encoded as an ordered list (v_1, v_2, \dots, v_n) of augmented spine vectors exactly m of which are nonzero; namely, by setting $v_i := \mathcal{F}^{-1}(i) \in \mathbf{spine}[m]$ when $i \in \underline{n}$ is in the image of the frame $\mathcal{F} : \mathbf{spine}[m] \hookrightarrow \underline{n}$, and setting $v_i := 0 \in \mathbf{spine}[m]_+$ otherwise. That last formulation, then, makes explicit contact with the corresponding linear algebraic notion of embedded frames on a vector space.

An embedded frame on a non-standard simplex is characterized similarly, as follows.

DEFINITION 1.1.41 (Embedded frame on a simplex). An n -**embedded frame of an unordered m -simplex** S is an isomorphism $S \cong [m]$, together with an n -embedded frame \mathcal{F} on that simplex $[m]$. —

Note that an m -embedded framed m -simplex is simply a framed m -simplex as previously defined. We usually denoted n -embedded framed m -simplices by pairs $(S \cong [m], \mathcal{F})$, though we may also leave the isomorphism implicit. As in the case of non-embedded frames, the choice of isomorphism is the same as a choice of spine for S (and thus a correspondence of that chosen spine with the standard spine of the standard simplex); we thus often think of an embedded frame of S as a choice of spine together with an injective assignment of numeral labels (in \underline{n}) to those spine vectors.

REMARK 1.1.42 (Embedded frames via affine faces). Note that the aforementioned interpretation of an embedded frame on a simplex S as a choice of spine $\mathbf{spine} S$ together with an injection $\mathbf{spine} S \hookrightarrow \underline{n}$, may be reexpressed as an affine face $S \hookrightarrow [n]$ (i.e. a choice of spine and an order-preserving injection $\mathbf{spine} S \hookrightarrow \mathbf{spine}[n] \cong \underline{n}$) together with an ordering on $\mathbf{spine} S$; that last formulation was the one displayed in [Figure 1.2](#). —

EXAMPLE 1.1.43 (Embedded frames on simplices). In [Figure 1.9](#) we illustrate a few n -embedded framed m -simplices $(S \cong [m], \mathcal{F})$. As before, the frame $\mathcal{F} : \mathbf{spine}[m] \hookrightarrow \underline{n}$ is indicated in three ways: the spine vector $v \in \mathbf{spine}[m]$ is labeled by its numeral value $\mathcal{F}(v) \in \underline{n}$, that numeral value is the number of arrowheads along the vector, and the labeled spine vectors are translated into a labeled coordinate frame. In that coordinate frame, we also depict the numerals that are not in the image of the frame $\mathcal{F} : \mathbf{spine}[m] \hookrightarrow \underline{n}$ as infinitesimal ‘curled-up’ dimensions; this evokes the partial inverse function $\mathcal{F}^{-1} : \underline{n} \rightarrow \mathbf{spine}[m] \sqcup \{0\}$ which sends those numerals to zero in the augmented spine. —

A linear embedding of an embedded framed simplex into euclidean space may preserve the frame structure in the following sense.

DEFINITION 1.1.44 (Framed realization of an embedded framed simplex). A **framed realization** of an n -embedded framed m -simplex $(S \cong [m], \mathcal{F})$,

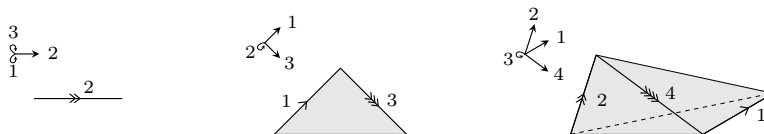

FIGURE 1.9. Embedded framed simplices.

with nondegenerate frame vectors $v_i = \mathcal{F}^{-1}(i)$, for $i \in \text{im}(\mathcal{F})$, is a linear embedding $r_{\mathcal{F}} : |S| \hookrightarrow \mathbb{R}^n$ of the geometric simplex $|S|$ into \mathbb{R}^n such that the translation vectors $\vec{v}_i := v_i(1) - v_i(0)$ are mapped into the i th positive standard component $\epsilon_i^+ \subset \mathbb{R}^n$, for all $i \in \text{im}(\mathcal{F})$. \square

EXAMPLE 1.1.45 (Framed realization of embedded framed simplices). In Figure 1.10 we illustrate framed realizations of the three 3-embedded framed 1-simplices. The framed realization of the vector with frame label 3 must be an affine vector whose associated linear vector (i.e. after translating its basepoint to the origin) is in ϵ_3^+ , which is to say a positive multiple of the basis vector e_3 . The framed realization of the vector with frame label 2 must be an affine vector whose associated linear vector is in ϵ_2^+ , that is the open half of the plane $\langle e_2, e_3 \rangle$ with positive e_2 coordinate. Finally, the framed realization of the vector with frame label 1 has associated linear vector in ϵ_1^+ , the open half of 3-space $\langle e_1, e_2, e_3 \rangle$ with positive e_1 coordinate.

Similarly, in Figure 1.11 we illustrate framed realizations of the six 3-embedded framed 2-simplices. We abuse notation slightly by only depicting the images of the simplices, and labeling the image vectors by the frame labels of the implicit corresponding source 2-simplex. As for the 3-embedded framed 1-simplices in the previous figure, all the vectors with frame label 3 point strictly in the positive e_3 direction, all the vectors with frame label 2 point in a positive e_2 direction inside the $\langle e_2, e_3 \rangle$ plane, and all the vectors with frame label 1 point in some positive e_1 direction in 3-space. \square

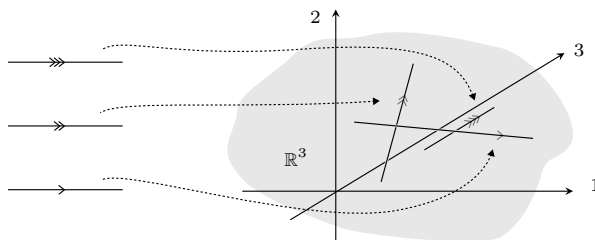

FIGURE 1.10. Framed realization of the 3-embedded framed 1-simplices.

Though in practice we will care only about embedded non-partial frames, we mention briefly the generalization of embedded frames to embedded partial

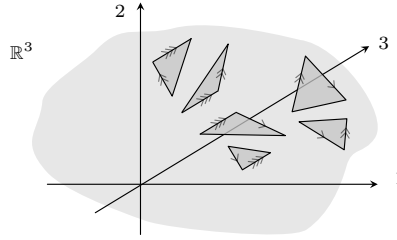

FIGURE 1.11. Framed realization of the 3-embedded framed 2-simplices.

frames. Partial frames provide frame labels on just some of the vectors of a simplex, and embedded frames allow frame labels in a higher numeral set; naturally embedded partial frames provide frame labels in a higher numeral set on just some of the vectors. We skip straight to the formulation for an arbitrary simplex, as follows.

DEFINITION 1.1.46 (Embedded partial frame on a simplex). An n -**embedded k -partial frame on an unordered m -simplex** S is a degeneracy $S \twoheadrightarrow T$ together with an n -embedded frame $(T \cong [k], \mathcal{F})$ on the target unordered k -simplex T . \square

Since the intermediate simplex T has, as part of the data of its embedded frame, a given isomorphism to the standard simplex, we usually omit the simplex T entirely and consider n -embedded k -partially framed simplices S to be pairs $(S \twoheadrightarrow [k], \mathcal{F})$, where \mathcal{F} is an n -embedded frame of the standard simplex $[k]$.

REMARK 1.1.47 (Embedded partial frames via affine maps). Note that the given definition of embedded partial frame on a simplex S may be yet again reconsidered as a degeneracy $S \twoheadrightarrow T$ to an ordered simplex T , together with an affine face $T \hookrightarrow [n]$ and an ordering of the spine of T ; that was the formulation displayed in Figure 1.2. \square

TERMINOLOGY 1.1.48 (Unframed subspace of an embedded partially framed simplex). The ‘unframed subspace’ of an n -embedded partially framed simplex $(S \twoheadrightarrow [k], \mathcal{F})$ is the kernel $\ker(S \twoheadrightarrow [k])$. As before this ‘subspace’ is actually a subset of the nondegenerate vectors of the simplex S . \square

EXAMPLE 1.1.49 (Embedded partial frames on simplices). In Figure 1.12 we illustrate a few n -embedded k -partially framed m -simplices $(S \twoheadrightarrow [k], \mathcal{F})$. We depict degeneracies $S \twoheadrightarrow [k]$ by highlighting their unframed subspace (in green) and illustrate the embedded framed simplices $([k], \mathcal{F})$ as in Example 1.1.43. Note that the embedded partial frame \mathcal{F} may also be recorded by labeling a vector v in S with $i \in \underline{n}$ (or with that many arrowheads) whenever its image $w := (S \twoheadrightarrow [k])(v) \in \text{spine}[k]$ has frame label $\mathcal{F}(w) = i$. \square

A linear map of an embedded partially framed simplex to euclidean space may preserve the frame structure in the following sense.

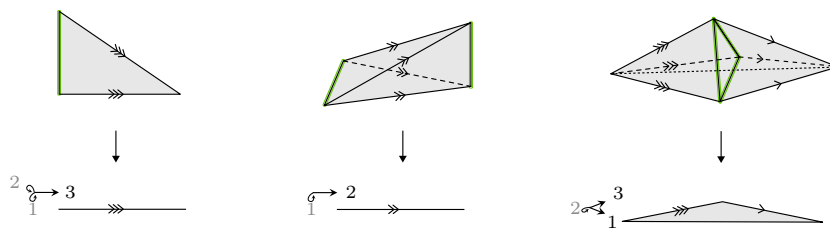

FIGURE 1.12. Embedded partially framed simplices.

DEFINITION 1.1.50 (Framed realization of an embedded partially framed simplex). Consider an n -embedded k -partially framed m -simplex $(S \twoheadrightarrow [k], \mathcal{F})$, with unframed subspace $U := \ker(S \twoheadrightarrow [k])$. A **framed realization** of the embedded partially framed simplex $(S \twoheadrightarrow [k], \mathcal{F})$ is a linear map $r_{\mathcal{F}} : |S| \rightarrow \mathbb{R}^n$ such that:

- > for all $v \notin U$ with image $w := (S \twoheadrightarrow [k])(v) \in \text{spine}[k]$ and $\mathcal{F}(w) = i$, the translation vector $\vec{v} := v(1) - v(0)$ is mapped into $\epsilon_i^+ \subset \mathbb{R}^n$, and
- > for all $v \in U$, the translation vector is mapped to $0 \in \mathbb{R}^n$. —

EXAMPLE 1.1.51 (Framed realization of embedded partially framed simplices). In Figure 1.13 we illustrate framed realizations of a 3-embedded 1-partial frame of the 3-simplex and of a 3-embedded 2-partial frame of the 4-simplex. —

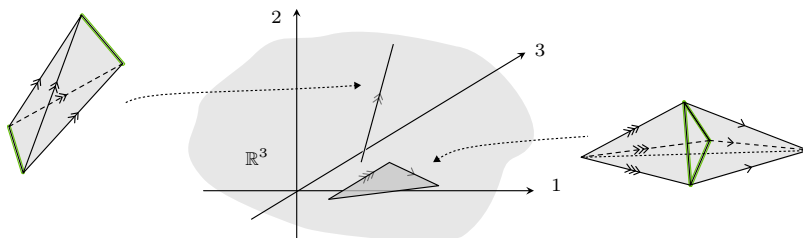

FIGURE 1.13. Framed realization of embedded partially framed simplices.

1.1.2. Framed maps.

SYNOPSIS. We explain how to restrict a frame on a simplex to a vector of the simplex, and then more generally to a simplicial face of the simplex. We define framed maps of framed simplices, as those simplicial maps that preserve the frame of every vector that is not degenerated; we conclude by discussing the class of subframed maps, in which a non-degenerated vector may have its frame either preserved or specialized.

1.1.2.1. Restricting frames.

MOTIVATION 1.1.52 (Restricting linear frames). Given a frame of a vector space V , conceived of classically as an ordered list of vectors (v_1, v_2, \dots, v_n) , one cannot naively restrict the frame to a subspace $W \hookrightarrow V$, which after all might contain none of the vectors whatsoever. Reinterpreting the frame as a linear isomorphism $V \xrightarrow{\sim} \mathbb{R}^n$, we obtain by restriction a linear embedding $W \hookrightarrow \mathbb{R}^n$. That embedding does not provide an ordinary frame, but, as in Motivation 1.1.39, we may consider a redundant frame $W \leftarrow \mathbb{R}^n$ split by that embedding, and then compress that redundant frame to an embedded frame of vectors in the subspace W . Of course, the same procedure works if instead of starting with a linear isomorphism $V \xrightarrow{\sim} \mathbb{R}^n$, we had started merely with a linear embedding $V \hookrightarrow \mathbb{R}^n$. \square

We present the simplicial analog of this process, namely restricting a frame, or more generally an embedded frame, on a simplex, to obtain an embedded frame on a simplicial face. This simplicial procedure has a concise geometric description, echoing the linear algebraic case, as follows.

REMARK 1.1.53 (Restricting frames via framed realization). Consider an n -embedded framed m -simplex $(S \cong [m], \mathcal{F})$, with a framed realization $r_{\mathcal{F}} : |S| \hookrightarrow \mathbb{R}^n$. The ‘restriction’ of the n -embedded frame of the simplex S , to a simplicial face $f : T \hookrightarrow S$, is the unique n -embedded frame of the simplex T , for which the linear embedding $r_{\mathcal{F}} \circ |f| : |T| \hookrightarrow |S| \hookrightarrow \mathbb{R}^n$ is a framed realization. \square

We now describe that frame restriction in purely combinatorial terms.

TERMINOLOGY 1.1.54 (Component spine vectors). A nondegenerate vector of an ordered simplex has a unique decomposition as a composite of spine vectors, called its ‘component spine vectors’. For instance, when the simplex is standard and the vector is $(a \rightarrow b)$, the component spine vectors are the vectors $(i \rightarrow i + 1)$ for $a \leq i < b$.⁷ \square

CONSTRUCTION 1.1.55 (Frame restriction to vectors of the standard simplex). Let $\mathcal{F} : \mathbf{spine}[m] \hookrightarrow \underline{n}$ be an n -embedded frame of the simplex $[m]$, and let $v := (a \rightarrow b) : [1] \rightarrow [m]$ be a vector of that simplex. The restriction $\mathcal{F}|_v : \mathbf{spine}[1] \hookrightarrow \underline{n}$ of the frame to that vector is the n -embedded frame of the

⁷The decomposition of simplicial vectors into component spine vectors allows us to define the following relation: two simplicial vectors (of the standard simplex) are ‘akin’, denoted $v \pm w$, when they share at least one component spine vector. This ‘kinship’ relation among simplicial vectors is a convenient combinatorial analog of euclidean vectors being non-orthogonal. Here we illustrate the kinship of vectors in the 3-simplex; vectors are akin exactly when they share a color highlight.

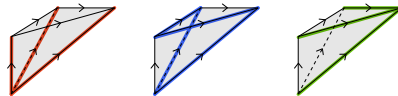

simplex $[1]$, whose single frame label is the minimum frame label among the component spine vectors of v , i.e.

$$\mathcal{F}|_v(0 \rightarrow 1) = \min\{\mathcal{F}((i \rightarrow i + 1)) \mid a \leq i < b\} \in \underline{n}. \quad \text{—}$$

Note that this combinatorial description aligns with the geometric description of Remark 1.1.53, as follows. For a vector v of the simplex $[m]$, the translation vector $\vec{v} := v(1) - v(0)$ is the sum $\sum_w \vec{w}$ of the translation vectors $\vec{w} := w(1) - w(0)$ of the component spine vectors w . In a framed realization $r_{\mathcal{F}} : |[m]| \rightarrow \mathbb{R}^n$ of the embedded framed simplex $([m], \mathcal{F})$, the translation vector \vec{w} is sent to a vector in the positive standard component $\epsilon_{\mathcal{F}(w)}^+$, i.e. with lowest nonzero and lowest positive coordinate being the $\mathcal{F}(w)$ coordinate; thus the sum $\sum_w \vec{w} = \vec{v}$ is sent to a vector in ϵ_i^+ for $i = \min_w \mathcal{F}(w)$, as required by the combinatorial description of the frame label.

This frame restriction procedure produces a plethora of combinatorial arrangements of framed vectors, quite distinct from any permutation of the restriction of the standard frame on the simplex.

EXAMPLE 1.1.56 (Frame restriction to simplicial vectors). In Figure 1.14 we illustrate various embedded framed 3-simplices, along with the framed restrictions to all their vectors. In Figure 1.15 we similarly illustrate the frame restrictions to the vectors of some framed 4-simplices. —

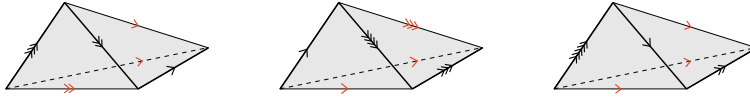

FIGURE 1.14. Restriction of embedded frames to vectors of 3-simplices.

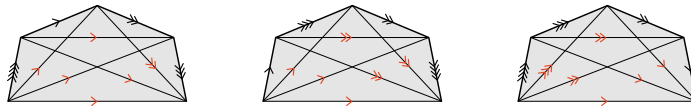

FIGURE 1.15. Restriction of frames to vectors of 4-simplices.

The restriction of an embedded frame to any simplicial face of an embedded framed simplex is determined directly by the restriction to the vectors, as follows.

CONSTRUCTION 1.1.57 (Frame restriction to simplicial faces of the standard simplex). Let $\mathcal{F} : \text{spine}[m] \hookrightarrow \underline{n}$ be an n -embedded frame of the simplex $[m]$, and let $f : [j] \hookrightarrow [m]$ be a simplicial face of that simplex. The restriction $\mathcal{F}|_f : \text{spine}[j] \hookrightarrow \underline{n}$ of the frame to that face is the n -embedded frame, whose frame label on each spine vector $v : [1] \rightarrow [j]$ is the numeral $\mathcal{F}|_{f \circ v}(0 \rightarrow 1) \in \underline{n}$,

i.e. the frame label of the restriction to that vector considered in the ambient simplex. ┌

The restriction of an embedded frame of a non-standard simplex is obtained by translation (along an ordering isomorphism) from the restriction for the standard simplex, as follows. We interject notation relevant for translation not just along isomorphisms but also degeneracies.

NOTATION 1.1.58 (Restriction of simplicial degeneracies along faces). Given a simplicial degeneracy $\alpha : S \twoheadrightarrow [k]$ (often for our purposes an isomorphism) from an m -simplex S to the standard simplex $[k]$, and a simplicial face $f : T \hookrightarrow S$, consider the image factorization of the composite $\alpha \circ f : T \rightarrow [k]$, as in the diagram

$$\begin{array}{ccc} T & \xrightarrow{f} & S \\ \alpha|_f \downarrow & & \downarrow \alpha \\ [l] & \xrightarrow{\alpha_! f} & [k] \end{array}$$

We refer to the left map $\alpha|_f : T \twoheadrightarrow [l]$ as the ‘restricted degeneracy’, i.e. the restriction of the degeneracy α along the face f , and to the bottom map $\alpha_! f : [l] \hookrightarrow [k]$ as the ‘induced face’, i.e. the induction of the face f along the degeneracy α . ┌

CONSTRUCTION 1.1.59 (Frame restriction to simplicial faces of a simplex). Let $(\alpha : S \cong [m], \mathcal{F})$ be an n -embedded frame of the m -simplex S , and let $f : T \hookrightarrow S$ be a simplicial l -face of that simplex. The ‘restriction’ $(\alpha|_f : T \cong [l], \mathcal{F}|_f)$ of the frame to that face is the n -embedded frame of the simplex T , consisting of the restricted isomorphism $\alpha|_f$ and the frame $\mathcal{F}|_f := \mathcal{F}|_{\alpha_! f}$, i.e. the restriction of the frame \mathcal{F} to the induced face $\alpha_! f : [l] \hookrightarrow [m]$. ┌

EXAMPLE 1.1.60 (Frame restriction to simplicial faces). In Figure 1.16 we depict a framed 4-simplex, along with the restriction of its frame to two simplicial faces. ┌

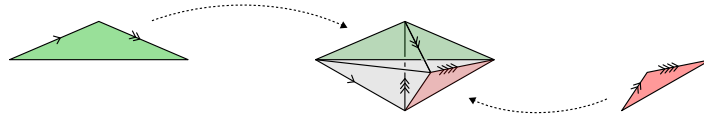

FIGURE 1.16. Restriction of a frame to faces of a simplex.

One may of course similarly define restrictions of embedded partial frames of simplices, as follows.

CONSTRUCTION 1.1.61 (Partial frame restriction to simplicial faces of a simplex). Let $(\alpha : S \twoheadrightarrow [k], \mathcal{F})$ be an n -embedded k -partial frame of the

m -simplex S , and let $f : T \hookrightarrow S$ be a simplicial face of that simplex. The ‘restriction’ ($\alpha|_f : T \twoheadrightarrow [l], \mathcal{F}|_f$) of the frame to that face is the n -embedded partial frame of the simplex T , consisting of the restricted degeneracy $\alpha|_f$ and the frame $\mathcal{F}|_f := \mathcal{F}|_{\alpha|_f}$, i.e. the restriction of the frame \mathcal{F} to the induced face $\alpha|_f : [l] \hookrightarrow [k]$. \square

REMARK 1.1.62 (Restricting partial frames via framed realization). As in the case of embedded frame restriction in Remark 1.1.53, the embedded partial frame restriction can be characterized geometrically, as follows. Consider an n -embedded k -partial frame $(S \twoheadrightarrow [k], \mathcal{F})$, with a framed realization $r_{\mathcal{F}} : |S| \rightarrow \mathbb{R}^n$. The restriction of the embedded partial frame, to a simplicial face $f : T \hookrightarrow S$, is the unique n -embedded partial frame of the simplex T , for which the linear map $r_{\mathcal{F}} \circ |f| : |T| \hookrightarrow |S| \rightarrow \mathbb{R}^n$ is a framed realization. \square

1.1.2.2. The definition of framed maps.

MOTIVATION 1.1.63 (Linear framed maps). Given two framed vector spaces $V \xrightarrow{\sim} \mathbb{R}^n$ and $W \xrightarrow{\sim} \mathbb{R}^n$, there is of course a unique map $V \xrightarrow{\sim} W$ strictly commuting with the frame isomorphisms. However, we may consider a map $V \rightarrow W$ to be compatible with the framings when, more generally, for each vector $v \in V$, either the map $V \rightarrow W$ commutes with the framings at that vector, or the map $V \rightarrow W$ sends that vector to zero. Similarly, for linear embeddings $V \hookrightarrow \mathbb{R}^n$ and $W \hookrightarrow \mathbb{R}^n$, there is at best one map $V \rightarrow W$ strictly commuting with the embeddings; but we consider a map $V \rightarrow W$ compatible (with the framings witnessed by those embeddings) when at every vector it either commutes with the embeddings or is zero. \square

We present the analogous combinatorial notion of framed maps of embedded framed simplices: a simplicial map is framed when it preserves the frame of every vector that is not degenerated.

DEFINITION 1.1.64 (Framed map of framed simplices). Consider n -embedded framed simplices $(S \cong [l], \mathcal{F})$ and $(T \cong [m], \mathcal{G})$. A **framed map** $F : (S \cong [l], \mathcal{F}) \rightarrow (T \cong [m], \mathcal{G})$ is a simplicial map $F : [l] \rightarrow [m]$ such that, for every vector $v : [1] \rightarrow [l]$ in the simplex $[l]$, either its frame label is preserved, i.e. $\mathcal{F}|_v = \mathcal{G}|_{F \circ v}$, or the vector is degenerated, i.e. $F \circ v : [1] \rightarrow [m]$ is constant. \square

(We could of course have formulated the definition instead in terms of a simplicial map $F : S \rightarrow T$ that is order preserving for the orders inherited from the respective frames.)

There are two subclasses of framed maps worth distinguishing, namely those whose simplicial map is injective or surjective.

TERMINOLOGY 1.1.65 (Framed faces). A ‘framed face’ is a framed map $F : (S \cong [l], \mathcal{F}) \hookrightarrow (T \cong [m], \mathcal{G})$ whose underlying simplicial map $F : [l] \hookrightarrow [m]$ is face map. Note that in this case the frame \mathcal{F} is the restriction $\mathcal{G}|_F$ of the frame \mathcal{G} along the simplicial map. \square

TERMINOLOGY 1.1.66 (Framed degeneracies). A ‘framed degeneracy’ is a framed map $F : (S \cong [l], \mathcal{F}) \twoheadrightarrow (T \cong [m], \mathcal{G})$ whose underlying simplicial map $F : [l] \twoheadrightarrow [m]$ is a degeneracy. —

NOTATION 1.1.67 (Category of embedded framed simplices). We will denote the category of n -embedded framed simplices and their framed maps by FrSimp_n . (Note that the objects of this category have underlying simplices of dimension at most n .) —

OBSERVATION 1.1.68 (Epi–mono factorization of framed maps). Any framed map of embedded framed simplices factors as a framed degeneracy followed by a framed face, as follows. Let $F : ([l], \mathcal{F}) \rightarrow ([m], \mathcal{G})$ be a framed map of n -embedded framed simplices. The underlying simplicial map $F : [l] \rightarrow [m]$ factors as a degeneracy $g : [l] \twoheadrightarrow [j]$ followed by a face $f : [j] \hookrightarrow [m]$. Consider the restriction of the frame \mathcal{G} to the face f as a frame $\mathcal{H} := \mathcal{G}|_f$ of the intermediate simplex $[j]$; certainly the map $f : ([j], \mathcal{H}) \rightarrow ([m], \mathcal{G})$ is a framed face. Since the face f is injective, the degeneracy g degenerates a vector $v : [1] \rightarrow [l]$ exactly when the composite $F = f \circ g$ degenerates that vector; and when the maps g and F do not degenerate v , the frame label is preserved: $\mathcal{H}|_{g \circ v} = \mathcal{G}|_{f \circ g \circ v} = \mathcal{G}|_{F \circ v} = \mathcal{F}|_v$. Thus the map g is a framed degeneracy $([l], \mathcal{F}) \twoheadrightarrow ([j], \mathcal{H})$, as required. —

EXAMPLE 1.1.69 (Framed and non-framed maps). In Figure 1.17 we illustrate three framed maps between 2-embedded framed simplices. The left one is a simplicial face map (with highlighted image), the middle one is a simplicial degeneracy (with highlighted affine kernel), the right one is a general simplicial map (with indicated image and affine kernel). These maps are framed since all the frame labels on nondegenerated vectors are preserved.

In Figure 1.18, by contrast, we illustrate three non-framed maps. The first is again a simplicial face, the second a simplicial degeneracy, and now the third is an unordered simplicial isomorphism. These are not framed maps: in the first two maps, some frame label of a nondegenerated vector is not preserved, and the third map is not even ordered. Note that in the second case, the map is not framed even though all spine vectors are either degenerated or have their frame label preserved, because the non-spine vector frame label is not preserved; framed maps cannot be naively detected by their frame behavior on spines. —

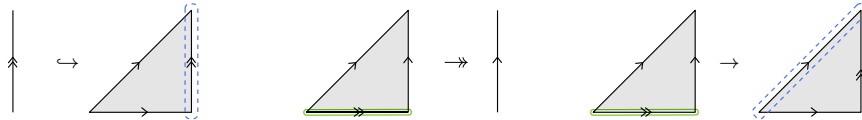

FIGURE 1.17. Framed maps of framed simplices.

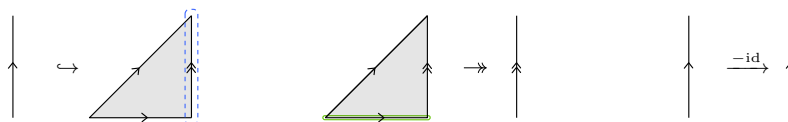

FIGURE 1.18. Non-framed maps of framed simplices.

REMARK 1.1.70 (Framed maps via framed realization). Framed maps may also be characterized more geometrically, in terms of framed realization, as follows. Consider n -embedded framed simplices $(S \cong [l], \mathcal{F})$ and $(T \cong [m], \mathcal{G})$, with framed realizations $r_{\mathcal{F}} : |S| \hookrightarrow \mathbb{R}^n$ and $r_{\mathcal{G}} : |T| \hookrightarrow \mathbb{R}^n$. A simplicial map $F : S \rightarrow T$ is framed exactly when, for any vector v whose translation vector is mapped into ϵ_i^+ by $r_{\mathcal{F}}$, its image $w := F(v)$ has translation vector mapped into $\epsilon_i^+ \cup \{0\}$ by $r_{\mathcal{G}}$. \square

EXAMPLE 1.1.71 (Framed maps via framed realization). For each of the three framed maps from Figure 1.17, we illustrate, in Figure 1.19, a framed realization of the source and target, together with an indication of the associated geometric map of subspaces of euclidean space, showing that the frame type of each of the simplicial vectors is preserved (or degenerated). \square

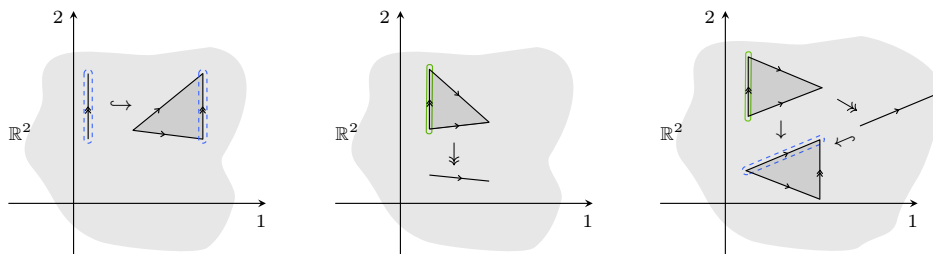

FIGURE 1.19. Framed maps via framed realization.

Note that the geometric characterization of framed maps from Remark 1.1.70 generalizes to maps of embedded partially framed simplices, by simply replacing the isomorphisms and linear embeddings by degeneracies and linear maps. The corresponding combinatorial formulation is as follows.

DEFINITION 1.1.72 (Framed maps of embedded partially framed simplices). Consider n -embedded partially framed simplices $(S \twoheadrightarrow [j], \mathcal{F})$ and $(T \twoheadrightarrow [k], \mathcal{G})$. A **framed map** $F : (S \twoheadrightarrow [j], \mathcal{F}) \rightarrow (T \twoheadrightarrow [k], \mathcal{G})$ is an (unordered) simplicial map $F : S \rightarrow T$ that descends to a simplicial map $\overline{F} : [j] \rightarrow [k]$ which is a framed map $\overline{F} : ([j], \mathcal{F}) \rightarrow ([k], \mathcal{G})$ of n -embedded framed simplices. \square

NOTATION 1.1.73 (Category of embedded partially framed simplices). We will denote the category of n -embedded partially framed simplices and their framed maps by $\mathbf{PartFrSimp}_n$. —

Framed maps either preserve the frame label of a vector or degenerate that vector to a zero vector. There is a more general notion of ‘subframed maps’, in which vectors may degenerate not just to a zero vector but to any vector with a more specialized frame label. These maps have an especially natural geometric description, as follows.

REMARK 1.1.74 (Subframed maps via framed realization). Consider n -embedded framed simplices $(S \cong [l], \mathcal{F})$ and $(T \cong [m], \mathcal{G})$, with framed realizations $r_{\mathcal{F}} : |S| \hookrightarrow \mathbb{R}^n$ and $r_{\mathcal{G}} : |T| \hookrightarrow \mathbb{R}^n$. A simplicial map $F : S \rightarrow T$ is ‘subframed’ exactly when, for any vector v whose translation vector is mapped into ϵ_i^+ by $r_{\mathcal{F}}$, its image $w := F(v)$ has translation vector mapped into the closure $\bar{\epsilon}_i^+$ by $r_{\mathcal{G}}$. —

Note that subframed maps may in particular send vectors with realization in a positive component ϵ_i^+ into vectors with a realization in a negative component $\epsilon_j^- \subset \bar{\epsilon}_i^+$ (with $j > i$).

Of course we can also define subframed maps in purely combinatorial terms.

DEFINITION 1.1.75 (Subframed map of framed simplices). Consider n -embedded framed simplices $(S \cong [l], \mathcal{F})$ and $(T \cong [m], \mathcal{G})$. A **subframed map** $F : (S \cong [l], \mathcal{F}) \rightarrow (T \cong [m], \mathcal{G})$ is an (unordered) simplicial map $F : S \rightarrow T$ such that, for every ordered vector $v : [1] \hookrightarrow S \cong [l]$, one of the following holds:

- (1) The frame label of v is *preserved*: $F \circ v : [1] \rightarrow T \cong [m]$ is an ordered vector with $\mathcal{F}|_v = \mathcal{G}|_{F \circ v}$.
- (2) The frame label of v is *specialized*: $F \circ v : [1] \rightarrow T \cong [m]$ is a possibly unordered vector with $\mathcal{F}|_v < \mathcal{G}|_{\pm(F \circ v)}$, where \pm denotes the sign choice making $\pm(F \circ v)$ an ordered vector.
- (3) The vector v is *degenerated*: $F \circ v : [1] \rightarrow T \cong [m]$ is constant. —

The definition of subframed maps extends to the embedded partially framed case, by insisting that any vector without a frame label is mapped either to a vector without a frame label or to zero.

EXAMPLE 1.1.76 (Subframed maps). The first two maps in Figure 1.18, though not framed, are subframed. In the first, the vector with frame label 1 is mapped to the vector with the (more specialized) frame label 2. Similarly in the second, the non-spine vector with frame label 1 is mapped to the target vector with frame label 2. The third simplicial map in that figure is not even subframed, because the source vector with frame label 1 is mapped to an antiorordered vector with the same, rather than strictly more specialized, frame label. If we modified that example so that the target framed 1-simplex had

the more specialized frame label 2, the resulting map of framed simplices would be subframed.

In Figure 1.20 we illustrate the framed realizations of those first two maps, along with the framed realization of the aforementioned modification of the third map. In these geometric depictions, we see that a vector with a positive coordinate in the 1-axial direction may specialize to a 2-axial vector, with either a positive or negative coordinate, since the closure of the halfplane ϵ_1^+ contains both the halflines ϵ_2^+ and ϵ_2^- . —┘

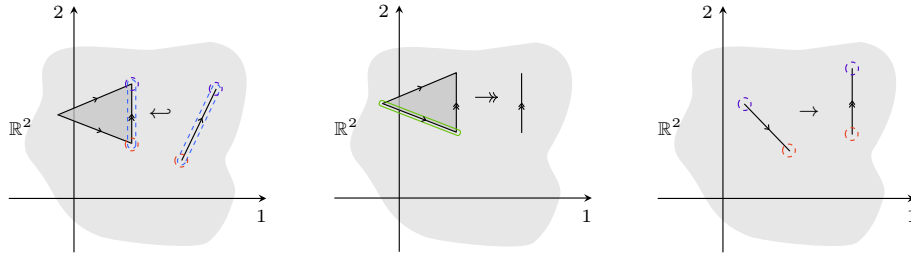

FIGURE 1.20. Subframed maps via their framed realizations.

1.2. Framed simplicial complexes

As elaborated in the previous section, our guiding analogy between linear algebra and affine combinatorics transmogrifies vector spaces and framed vector spaces into simplices and framed simplices. Patching together vector spaces yields manifolds, and patching together framed vector spaces yields framed manifolds; similarly, gluing simplices gives of course simplicial complexes, and gluing framed simplices will give *framed simplicial complexes*. An example of a framed simplicial complex is illustrated on the top left in Figure 1.21; in this complex, each of the 2-simplices is framed, in such a way that each shared 1-simplex inherits, by restriction, a well-defined 2-embedded framing.

Patching framed vector spaces along open subspaces ensures a smooth local triviality of the resulting global framing; by contrast, gluing framed simplices along boundary faces allows for singularities in the resulting global combinatorial framing. When no such singularities occur, the framed simplicial complex is called *framed collapsible*; that term is apt because framed collapsible complexes admit a sequence of elementary collapses degenerating all the vectors of the complex in weakly descending frame label order (and in a canonical progression within the vectors of a fixed frame label). For example, the right half of the complex in the figure is framed collapsible: both the 1-frame and 2-frame vectors sweep out an uninterrupted and non-degenerating pattern of frame directions on the complex; and indeed the indicated projection to \mathbb{R}^2 is a non-singular embedding. By contrast, the left half of that complex is not framed collapsible: the 2-frame vectors of the left three 2-simplices alternate directions, conveying a degeneration of the framing along the intervening 1-simplices; and indeed the indicated projection to \mathbb{R}^2 (which is characterized by restricting to a framed realization of each component framed simplex) has a locus of combinatorial fold singularities.

The corresponding smooth situation, depicted in the bottom row of the figure, is a generic map from a 2-disc to \mathbb{R}^2 , having a 1-dimensional locus of fold singularities and a single point cusp singularity. Away from the differential singular locus, the tangential 2-framing of \mathbb{R}^2 lifts to a 2-framing of the 2-disc, but that 2-framing degenerates to a 1-framing on the fold locus, and further degenerates to a 0-framing at the cusp point. Altogether the framed simplicial complex and its framed realization to euclidean space provide a faithful combinatorial model of this classical singularity.

OUTLINE. In Section 1.2.1, we introduce framings on simplicial complexes, as a compatible system of embedded framings of the constituent simplices. In Section 1.2.2, we define collapsible framed simplicial complexes to be those framed complexes that have a suitable sequence of elementary collapses, degenerating the vectors in descending order of their frame labels; we then mention progressive framed complexes as those that are locally collapsible.

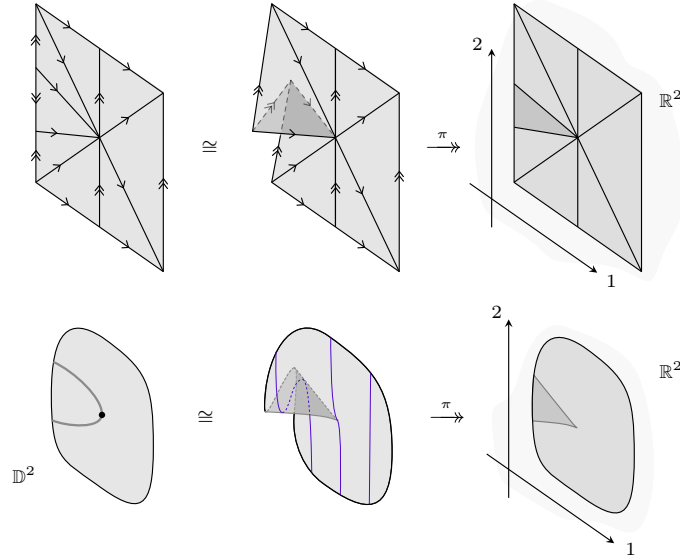

FIGURE 1.21. A framed simplicial complex and a differential singularity.

1.2.1. Framings on simplicial complexes.

SYNOPSIS. We review the notions of unordered and ordered simplicial complexes and their simplicial maps. We define a framing on a simplicial complex to be a choice of embedded framing on each constituent simplex, which are compatible under restriction to faces; we then introduce framed maps of framed simplicial complexes as simplicial maps whose restriction to each simplex is framed.

1.2.1.1. Unordered and ordered simplicial complexes.

TERMINOLOGY 1.2.1 (Simplicial complexes). A ‘simplicial complex’ K consists of a set of vertices $K(0)$ together with a subset $K(i) \subset \wp K(0)$ of the vertex powerset, for each $i \geq 1$, with every ‘ i -simplex’ $x \in K(i)$ having cardinality $i + 1$, such that any subset of an i -simplex $x \in K(i)$ is itself a j -simplex $y \in K(j)$, for the relevant $j \leq i$. —

Fluidly considering a simplicial complex as both containing and consisting of its simplices, we will write $x : S \hookrightarrow K$ (also just $S \hookrightarrow K$) to mean $x : S \hookrightarrow K(0)$ with $\text{im}(x) \in K(i)$, and in this case we will typically refer to the simplex as x or S rather than as $\text{im}(x)$ per se.

TERMINOLOGY 1.2.2 (Simplicial maps of simplicial complexes). For simplicial complexes K and L , a ‘simplicial map’ $K \rightarrow L$ is a map of vertex sets $f : K(0) \rightarrow L(0)$, such that for every i -simplex $x \in K(i)$, the image is a j -simplex $f(x) \in L(j)$, for some j .

We denote the category of simplicial complexes and their simplicial maps by SimpCplx . —

Of course the set of all subsets of a combinatorial simplex is a simplicial complex, and so in this sense simplices are simplicial complexes.

A simplex of a simplicial complex, as a bare subset of the vertex set, is unordered; as such, the above constitutes a notion of unordered simplicial complex. Orderings of unordered simplices were crucial in our discussion of framed simplices, and so orderings of unordered simplicial complexes will be essential for our definition of framed simplicial complexes.

TERMINOLOGY 1.2.3 (Ordered simplicial complexes). An ‘ordered simplicial complex’ K is a simplicial complex together with a choice of order on the vertices of each simplex, which are compatible with one another in the sense that the ordering of any simplex restricts to the ordering of any of its faces.⁸ —

TERMINOLOGY 1.2.4 (Simplicial maps of ordered simplicial complexes). For ordered simplicial complexes K and L , a ‘simplicial map’ $K \rightarrow L$ is a map of vertex sets $f : K(0) \rightarrow L(0)$, such that for every i -simplex $x \in K(i)$, the image is a j -simplex $f(x) \in L(j)$, and the map $f|_x : x \rightarrow f(x)$ is order preserving.

We denote the category of ordered simplicial complexes and their simplicial maps by $\mathbf{SimpCplx}^{\text{ord}}$. —

TERMINOLOGY 1.2.5 (Unordering simplicial complexes). The ‘unordering’ K^{un} of an ordered simplicial complex K is simply the underlying unordered simplicial complex, i.e. the one obtained by forgetting the order on each simplex. —

REMARK 1.2.6 (Unordered and ordered simplicial complexes as symmetric and simplicial sets). We mention the relationship between combinatorial simplicial complexes and presheaves on categories of simplices, though the presheaf perspective will not be needed and this remark may be safely skipped. Recall from **Notations 1.1.2** and **1.1.3** and **Terminology 1.1.4** the categories Δ and $\underline{\Delta}$ of ordered simplices and unordered simplices, respectively, and the unordering functor $u := (-)^{\text{un}} : \Delta \rightarrow \underline{\Delta}$ between them. Let $i : \Delta^{\text{inj}} \subset \Delta$ and $i : \underline{\Delta}^{\text{inj}} \subset \underline{\Delta}$ denote the wide subcategories containing the injective i.e. face maps. Presheaves of sets on these four simplex categories are more and less familiar as follows:

$$\begin{aligned} \mathbf{SSet} &= \mathbf{PSh}(\Delta) && \text{simplicial sets} \\ \mathbf{SSSet} &= \mathbf{PSh}(\Delta^{\text{inj}}) && \text{semi-simplicial sets} \\ \mathbf{SymSet} &= \mathbf{PSh}(\underline{\Delta}) && \text{symmetric sets} \\ \mathbf{SSymSet} &= \mathbf{PSh}(\underline{\Delta}^{\text{inj}}) && \text{semi-symmetric sets} \end{aligned}$$

We have the restriction functors $i^* : \mathbf{SSet} \rightarrow \mathbf{SSSet}$ and $i^* : \mathbf{SymSet} \rightarrow \mathbf{SSymSet}$ that forget degeneracies, and the restriction functors $u^* : \mathbf{SSymSet} \rightarrow \mathbf{SSSet}$ and $u^* : \mathbf{SymSet} \rightarrow \mathbf{SSet}$ that forget permutation actions; the left

⁸As given, we conceive of these complexes as ‘locally’ ordered; by contrast a ‘globally’ ordered simplicial complex would be a complex with an order on the set of all its vertices [**RS71**, §1].

adjoints $i_!$ freely adjoin degeneracies, and similarly the left adjoints $u_!$ freely generate permutation actions.

Ordered simplicial complexes embed (fully faithfully) into semi-simplicial sets: assign to the ordered complex K the presheaf whose value at the ordered simplex $[m]$ is the set of injections $[m] \hookrightarrow K(0)$ which order-preservingly delineate a simplex. Similarly, unordered simplicial complexes embed (fully faithfully) into semi-symmetric sets: assign to the unordered complex K the presheaf whose value at the simplex S is the set of injections $S \hookrightarrow K(0)$ which delineate a simplex. Altogether then, we have the following diagram in which the left square and the square of left adjoints commute.

$$\begin{array}{ccccc}
 \text{SimpCplx}^{\text{ord}} & \longrightarrow & \text{SSSet} & \begin{array}{c} \xrightarrow{i_!} \\ \xleftarrow{i^*} \end{array} & \text{SSet} \\
 \downarrow (-)^{\text{un}} & & \begin{array}{c} \uparrow u^* \\ \downarrow u_! \end{array} & & \begin{array}{c} \uparrow u^* \\ \downarrow u_! \end{array} \\
 \text{SimpCplx} & \longrightarrow & \text{SSymSet} & \begin{array}{c} \xrightarrow{i_!} \\ \xleftarrow{i^*} \end{array} & \text{SymSet}
 \end{array}$$

In particular the adjoints $u_!$ to the unordering of simplices u^* provide presheaf versions of the unordering functor $(-)^{\text{un}}$ on complexes. —

1.2.1.2. The definition of framed simplicial complexes. Recall from Definitions 1.1.40 and 1.1.41 that an embedded frame of an individual unordered simplex S is an isomorphism $\alpha : S \cong [m]$ that orders S , together with an embedded frame of the standard simplex $[m]$, which in turn is an injection $\mathcal{F} : \text{spine}[m] \hookrightarrow \underline{n}$ from the simplex spine into the numerals. Recall also from Constructions 1.1.57 and 1.1.59 that such an embedded frame of a simplex S restricts along a j -face $f : T \hookrightarrow S$, to an embedded frame of the face, given by the restricted isomorphism $\alpha|_f : T \cong [j]$ and the restricted embedded frame $\mathcal{F}|_f$.

DEFINITION 1.2.7 (Framings of simplicial complexes). An n -**framing of a simplicial complex** K is a choice of n -embedded frame $(\alpha_S : S \cong [m], \mathcal{F}_S)$ for each simplex $S \hookrightarrow K$ of the complex, which are compatible in the sense that for any face $f : T \hookrightarrow S$, the restriction of the chosen frame of S is the chosen frame of T , i.e. $\alpha_T = \alpha_S|_f$ and $\mathcal{F}_T = \mathcal{F}_S|_f$. —

The restriction of an actual n -frame of an n -simplex to a proper face is of course just an n -embedded frame. There is therefore no sensible notion of a non-embedded frame of a simplicial complex; thus the preferencing of the term ‘ n -framing’ to refer to a collection of compatible embedded frames, as above. Note that an n -framed simplicial complex has simplicies of dimension at most n .

OBSERVATION 1.2.8 (Framing provides an ordering). In a framing of a simplicial complex, by definition the collection of isomorphisms $\alpha_S : S \cong [m]$ is compatible under restriction to faces, and therefore constitutes an ordering of the simplicial complex. —

In light of that observation, we may mildly rephrase the notion of framing of a complex : a framing of a simplicial complex is an ordering of the complex together with a compatible choice of embedded frames on its ordered simplices. Similarly, if we have a complex already equipped with an ordering, the notion of framing simplifies as follows.

DEFINITION 1.2.9 (Framings of ordered simplicial complexes). An n -**framing of an ordered simplicial complex** K is a choice of n -embedded frame $\mathcal{F}_x : \text{spine}[m] \hookrightarrow \underline{n}$ of each ordered simplex $x : [m] \hookrightarrow K$ of the complex, which are compatible in the sense that for an ordered face $f : [l] \hookrightarrow [m]$, the restriction of the chosen frame of x is the chosen frame of $x \circ f$, i.e. $\mathcal{F}_{x \circ f} = \mathcal{F}_x|_f$. —

CONVENTION 1.2.10 (Keeping orderings implicit). In discussing framed simplicial complexes (K, α, \mathcal{F}) , consisting of a simplicial complex K , an ordering α of the complex K , and a framing \mathcal{F} of the ordered complex (K, α) , we will tend to suppress the ordering, denoting the framed complex by merely (K, \mathcal{F}) and considering the complex K , and so its component simplices, to be implicitly ordered as convenient. —

Recall that for an individual simplex, the frame labels of the spine determine the frame restriction to any simplicial vector, which in turn prescribe the frame restriction to any simplicial face. Since the frame of a complex is defined simplex-wise, a framed complex is similarly encoded by the frame labels of its vectors.

TERMINOLOGY 1.2.11 (Frame labels and frame vectors). As for individual framed simplices, the ‘frame label’ of a simplicial vector $v : [1] \hookrightarrow K$ in a framed simplicial complex (K, \mathcal{F}) is the numeral $\mathcal{F}|_v(0 \rightarrow 1) \in \underline{n}$. A ‘frame k -vector’ is a simplicial vector whose frame label is k . —

REMARK 1.2.12 (Frame vector notation caution). In drawing examples of framed simplicial complexes, of course we specify the frame by just providing the frame labels of the simplicial vectors of the complex. But note well that an arbitrary labeling of the simplicial vectors of a complex with numerals need not define a framing; one must check that the labeling determines a valid frame on each simplex separately. —

EXAMPLE 1.2.13 (Framings and non-framings on simplicial complexes). In [Figure 1.22](#), we depict two 2-framed simplicial complexes. The framing is indicated by the notation wherein edges with frame label 1, that is frame 1-vectors, have a single arrow, and edges with frame label 2, that is frame 2-vectors, have a double arrow. The left complex is a 2-sphere (in fact the minimal triangulation thereof), and the right complex is a 2-torus (again the minimal triangulation). (Notice that a manifold need not have a tangential framing in the classical sense in order to have a combinatorial framing in our sense; the point being that our more general notion of framing allows various singularities of the framing. The notion of progressive framing described later

is more closely analogous to the classical notion of (nonsingular) tangential framing.)

In Figure 1.23, we depict on the left an unordered simplicial complex that admits no 2-framing whatsoever. (As it happens, this is the minimal triangulation of the real projective plane.) On the right, we have an ordered simplicial complex that admits no 2-framing. (This one is a minimal triangulation of the Klein bottle.)

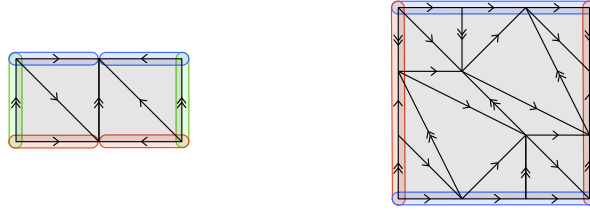

FIGURE 1.22. Simplicial complexes with a 2-framing.

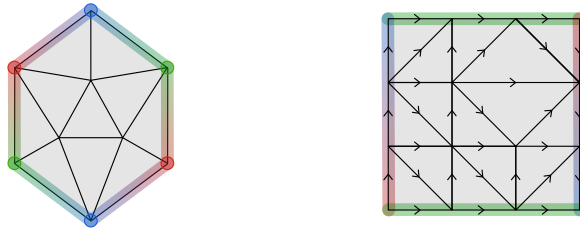

FIGURE 1.23. Simplicial complexes with no 2-framing.

Framed realizations into euclidean space are a convenient method for visualizing framed simplicial complexes, as they were for individual framed simplices. Recall from Definition 1.1.44 that a framed realization of an embedded framed simplex is a linear embedding for which each frame i -vector is mapped to a translation in the i th positive standard component.

DEFINITION 1.2.14 (Framed realization of a framed simplicial complex). A **framed realization** of an n -framed simplicial complex (K, α, \mathcal{F}) is a linear map $r : |K| \rightarrow \mathbb{R}^n$ (that is, a map that is linear on each simplex) such that, for each simplex $S \hookrightarrow K$, the restriction $r|_{|S|} : |S| \rightarrow \mathbb{R}^n$ is a framed realization of the framing $(\alpha_S, \mathcal{F}_S)$ of the simplex S .

EXAMPLE 1.2.15 (Framed realizations of framed simplicial complexes). In Figure 1.24 we illustrate various 2-framings of a square simplicial complex, along with corresponding framed realizations.

Note that not all framed simplicial complexes admit framed realizations in \mathbb{R}^n . (For instance, the circular framing of the boundary of a 2-simplex is a non-realizable 1-framed simplicial complex.)

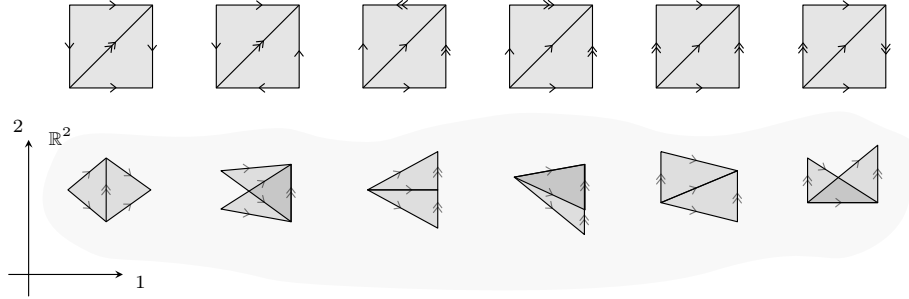

FIGURE 1.24. Simplicial complexes with 2-framings and their framed realizations.

Recall the notion of framed maps of framed simplices from Definition 1.1.64. Maps of framed simplicial complexes are simply maps that are framed on each simplex, as follows.

DEFINITION 1.2.16 (Framed maps of framed simplicial complexes). Consider n -framed simplicial complexes (K, \mathcal{F}) and (L, \mathcal{G}) . A **framed simplicial map** $F : (K, \mathcal{F}) \rightarrow (L, \mathcal{G})$ is a simplicial map $F : K \rightarrow L$, such that for every (ordered) simplex $x : [k] \hookrightarrow K$, the restriction $F|_x : ([k], \mathcal{F}_x) \rightarrow ([l], \mathcal{G}_y)$ is a framed map, where $y := \text{im}(F \circ x) : [l] \hookrightarrow L$ is the image of the composite $F \circ x$. —

We tend to refer to framed simplicial maps simply as ‘framed maps’. Note that framed maps of simplicial complexes are order preserving (since their constituent framed maps on simplices are order preserving by definition).

NOTATION 1.2.17 (The category of framed simplicial complexes). We will denote the category of n -framed simplicial complexes and framed simplicial maps by FrSimpCplx_n . —

NOTATION 1.2.18 (Unframing framed simplicial complexes). We will denote by $\text{Unframe} : \text{FrSimpCplx}_n \rightarrow \text{SimpCplx}$ the forgetful ‘unframing’ functor, taking framed simplicial complexes and framed maps to their underlying simplicial complexes and simplicial maps. —

TERMINOLOGY 1.2.19 (Frame restriction to simplicial subcomplexes). Let \mathcal{F} be an n -framing of a simplicial complex K , and let $f : L \hookrightarrow K$ be a subcomplex. The ‘restriction’ $\mathcal{F}|_L$ of the framing \mathcal{F} to the subcomplex L is the n -framing obtained by restricting the ordering of the complex K to the subcomplex L , and restricting the framing itself to each simplex of the subcomplex, i.e. $(\mathcal{F}|_L)_x := \mathcal{F}_{f \circ x}$ for $x : [k] \hookrightarrow L$. —

Of course, given such a frame restriction, there is a framed simplicial map $(L, \mathcal{F}|_L) \hookrightarrow (K, \mathcal{F})$ from the restricted framed complex to the ambient framed complex.

REMARK 1.2.20 (Subframed maps of framed simplicial complexes). Recall from Definition 1.1.75 that subframed maps of simplices, unlike framed maps, may specialize frame labels. A ‘subframed map of framed simplicial complexes’ $F : (K, \mathcal{F}) \rightarrow (L, \mathcal{G})$ is a simplicial map $F : K \rightarrow L$, such that for every ordered simplex $x : [k] \hookrightarrow K$, the restriction $F|_x : ([k]^{\text{un}} \cong [k], \mathcal{F}_x) \rightarrow ([l]^{\text{un}} \cong [l], \mathcal{G}_y)$ is a subframed map, where $y := \text{im}(F \circ x) : [l] \hookrightarrow L$ is the image of the composite $F \circ x$. Note that, unlike framed maps, subframed maps need not be order preserving. \square

Our discussion of framings on simplicial complexes would not be quite complete without mentioning the generalization to partial framings, as follows.

DEFINITION 1.2.21 (Partial framings of simplicial complexes). A **partial n -framing of a simplicial complex K** is a choice of n -embedded partial frame $(\alpha_S : S \twoheadrightarrow [k], \mathcal{F}_S)$ for each simplex $S \hookrightarrow K$, which are compatible in the sense that for any face $f : T \hookrightarrow S$, the restriction of the chosen frame of S is the chosen frame of T . \square

Note that a partially n -framed simplicial complex may have simplicies of any dimension. Also note that, unlike Observation 1.2.8 for framings, a partial framing typically does not determine an ordering on the simplicial complex.

EXAMPLE 1.2.22 (Partially framed simplicial complex). In the figure at the beginning of the Introduction, we depicted a partial 1-framing of a 2-dimensional simplicial complex. Each of the eight 2-simplices has a 1-partial frame with two 1-framed 1-simplex faces and one unframed 1-simplex face. Indeed those partial frames are specified by the indicated degeneracy maps to the respective 1-framed 1-simplices on the right. As the figure suggests, this partially framed simplicial complex provides a combinatorial model of the classical differential Morse singularity of index 1. \square

We will be concerned almost exclusively with the situation of non-partial embedded framings, and henceforth for the most part forgo the routine of describing the partial variations; nevertheless, the subsequent definitions in this chapter may be suitably generalized to the partial case, as desired.

1.2.2. Collapsible framings.

SYNOPSIS. We defined collapsible framed simplicial complexes as those admitting a sequence of elementary collapses, consecutively degenerating all vectors in weakly descending order of their frame labels, with every collapse along the way satisfying a simplicial lifting condition and with every complex along the way satisfying a unique framed simplicial extension property. We then introduce progressive framed simplicial complexes as those framed complexes that are locally collapsible.

1.2.2.1. The definition of framed collapse. Recall that classically, an elementary collapse of a simplicial complex is the simultaneous removal of an open simplex and a free open face of that simplex; a complex is collapsible when it admits a sequence of elementary collapses ending in a point. Each elementary collapse is a simple homotopy equivalence and so certainly a collapsible complex is contractible. Furthermore, a complex is contractible precisely when it can be reduced to a point by a sequence of both elementary collapses and elementary expansions (that is, the inverse operation) [Whi39, Coh73]. We adopt a different approach to constructive collapsibility, where instead of successively removing free simplices, one successively contracts edges whose local combinatorial topology is suitably trivial (cf. also the related but distinct approach of discrete Morse theory [For98, For02]). We will coopt the classical terminology and refer instead to such edge contractions as elementary collapses. Note a crucial technical distinction between these viewpoints is that classical elementary collapses are not simplicial maps (but their inverse expansions are), while our elementary collapses are simplicial maps (but their inverse expansions are not).

We proceed to develop a framed analog of collapsibility. The component operation of ‘framed elementary collapse’ will be the contraction of a ‘highest frame vector’ (that is, a frame vector whose frame label is maximal across the whole complex). A framed complex is framed collapsible when it admits a sequence of framed elementary collapses ending in a point, with each component collapse satisfying a simplicial lifting condition and each intermediate complex satisfying a framed simplicial extension condition. Because such a sequence of collapses degenerates frame vectors in order, from highest to lowest, a framed collapsible simplicial complex obtains a rigid moral geometry: there are unique combinatorial ‘flow’ lines traversing the highest frame vectors, and furthermore there are flow lines traversing the next highest frame direction, which though are only determined up to discrete deformation by the highest frame vectors, and so forth—altogether there is a hierarchy of combinatorial flow lines in every frame direction, each of which is specified up to alteration by higher frame vectors.⁹

Given a simplex of an ordinary unordered simplicial complex, one may form a naive quotient complex, by simply identifying the vertices of the simplex, as follows.

CONSTRUCTION 1.2.23 (Quotient simplicial complexes). Consider a simplicial complex K , and a chosen simplex $x : S \hookrightarrow K$. The ‘quotient simplicial complex’ K/x has vertex set $K(0)/S$, together with those simplices $T \subset K(0)/S$ that are images of simplices of K (under the quotient $K(0) \rightarrow K(0)/S$). The vertex set quotient defines a simplicial map $q_x : K \rightarrow K/x$ from the complex to its quotient complex. \square

⁹This hierarchy can be made precise as a complete flag of combinatorial foliations of the simplicial complex.

Such a quotient is naive in the sense that it indiscriminately identifies simplices in the complex that may not be homotopically related; in particular, this quotient typically does not preserve the homotopy type of the geometric realization. However, there is a convenient combinatorial condition that ensures the quotient is better behaved; we restrict attention to quotients by 1-simplices.

TERMINOLOGY 1.2.24 (Admissible 1-simplex). A 1-simplex $v = \{a, b\}$ of a simplicial complex K is ‘admissible’ when the link $\text{link}(v)$ is the intersection $\text{link}(a) \cap \text{link}(b)$ of its two vertex links. (The link $\text{link}(s) \subset K$ of a simplex s is the subcomplex consisting of simplices $t \in K$ that are disjoint from s and for which the union $s \cup t$ is a simplex of K .) —

TERMINOLOGY 1.2.25 (Elementary collapse). An ‘elementary collapse’ of a simplicial complex K is a quotient $q_v : K \rightarrow K/v$ by an admissible 1-simplex $v \in K$. —

Note that an elementary collapse is in particular a simple homotopy equivalence.

We can now introduce a framed version of elementary collapse, by insisting on collapsing frame vectors with maximal frame labels, as follows.

TERMINOLOGY 1.2.26 (Highest frame vector). For an n -embedded framed m -simplex $(S \cong [m], \mathcal{F})$, ‘the highest frame vector’ is the unique vector $h^{\mathcal{F}} : [1] \rightarrow S$ whose frame label k is maximal among all the frame labels of the simplex.

For a framed simplicial complex (K, \mathcal{F}) , the ‘highest frame number’ is the maximal frame label k among all the simplicial vectors of the complex. For a complex with highest frame number k , ‘a highest frame vector’ is a simplicial vector with frame label k . —

EXAMPLE 1.2.27 (Highest frame vectors of framed simplices). In Figure 1.25, we depict a 4-embedded framed 3-simplex and a framed 4-simplex, highlighting in each case the highest frame vector. —

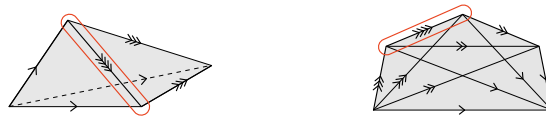

FIGURE 1.25. Highest frame vectors of framed simplices.

TERMINOLOGY 1.2.28 (Framed elementary collapse). Consider an n -framed simplicial complex (K, \mathcal{F}) . A ‘framed elementary collapse’ is an elementary collapse $K \rightarrow K/v$ of a highest frame vector v of the framed complex (K, \mathcal{F}) . —

We should check that last claim [See argument below.]

For specificity, when the highest frame number of the complex is k , we may refer to the collapse of a frame k -vector as a ‘framed elementary k -collapse’.

Framings descend along framed elementary collapses, as follows.

LEMMA 1.2.29 (Framed elementary collapses are framed maps). *When $q_v : K \rightarrow K'$ is a framed elementary collapse of a framed simplicial complex (K, \mathcal{F}) , there is a unique framing \mathcal{F}' on the complex K' , such that the quotient q_v is a framed simplicial map.*

PROOF. For each simplex $x : S \hookrightarrow K'$ of the quotient, choose a lift $\tilde{x} : S \hookrightarrow K$; set the frame $(S \cong [m], \mathcal{F}'_x)$ to be simply the frame $(S \cong [m], \mathcal{F}_{\tilde{x}})$ of the lift. The only potential ambiguity occurs when there are two lifts \tilde{x} and \hat{x} , which differ at exactly one point and exactly by the highest frame vector v . Since the frame label of v is maximal, the framings $\mathcal{F}_{\tilde{x}}$ and $\mathcal{F}_{\hat{x}}$ are identical. Given that framing on the target complex K' , the quotient $K \rightarrow K'$ is framed by construction. \square

EXAMPLE 1.2.30 (Collapse of highest frame vectors). In Figure 1.26 we illustrate four 2-framed simplicial complexes K with highest frame number 2, and indicate a highest frame vector v in each of them. In each case, we depict the quotient simplicial map $q_v : K \rightarrow K/v$. The first three cases are framed elementary collapses, but the last case is not, because there the highest frame vector is not admissible. $\text{—}\perp$

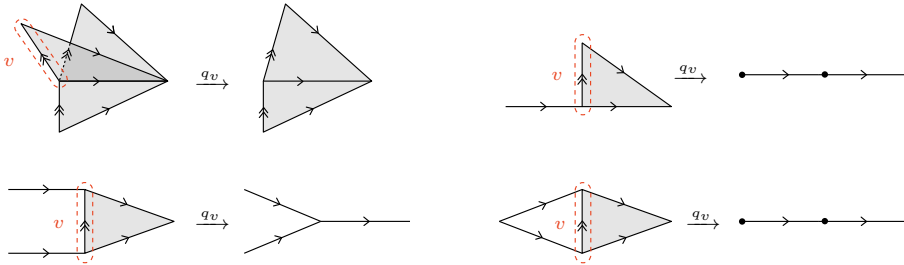

FIGURE 1.26. Collapse of highest frame vectors.

Equipped with the notion of framed elementary collapse, we may define framed collapsible complexes as those admitting a suitable sequence of framed elementary collapses, eventually ending in a trivial complex, as follows.

DEFINITION 1.2.31 (Framed collapsible complex). A framed simplicial complex (K, \mathcal{F}) is **framed collapsible** when, either its highest frame number is zero and the complex is a point, or its highest frame number k is positive and the following conditions are satisfied:

- (1) *Inductive collapsibility.* The complex (K, \mathcal{F}) admits a sequence of framed elementary k -collapses resulting in a framed collapsible complex (K', \mathcal{F}') with highest frame number strictly less than k . (We refer to the composite $q_k : (K, \mathcal{F}) \rightarrow (K', \mathcal{F}')$ of such a sequence as a ‘framed k -collapse’.)

- (2) *Flow existence.* For any m -simplex $x : [m] \hookrightarrow K'$, and any vertex $a \in K$ with collapse image $q_k(a) \in \text{im}(x) \subset K'$, there exists a ‘flow section’ simplex $\tilde{x} : [m] \hookrightarrow K$ (i.e. with $q_k \circ \tilde{x} = x$), containing the vertex a .
- (3) *Flow uniqueness.* For any simplex $y : [m] \hookrightarrow K$ not containing a highest frame vector $[1] \hookrightarrow K$, there exists at most one ‘positive flow spacer’ simplex $y^+ : [m+1] \hookrightarrow K$, containing both y and a highest frame vector $v : [1] \hookrightarrow K$ with initial vertex $v(0) \in \text{im}(x)$, and there exists at most one ‘negative flow spacer’ simplex $y^- : [m+1] \hookrightarrow K$, containing both y and a highest frame vector $v : [1] \hookrightarrow K$ with final vertex $v(1) \in \text{im}(x)$. —

We say a framing of a simplicial complex is ‘collapsible’ when that framed simplicial complex is framed collapsible, and we refer to a framed collapsible framed simplicial complex simply as a ‘collapsible framed simplicial complex’.

EXAMPLE 1.2.32 (Collapsible framings). In Figure 1.27, we depict four collapsible 1-framed simplicial complexes. These are all linear directed graphs because indeed those are the only such complexes.

In Figure 1.28, we depict four collapsible 2-framed simplicial complexes with highest frame number 2; in each case we show the framed 2-collapse to a collapsible 2-framed simplicial complex with highest frame number 1. —



FIGURE 1.27. Collapsible 1-framed simplicial complexes.

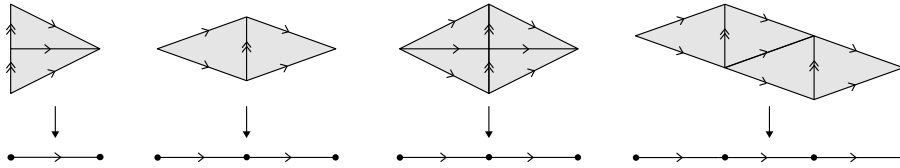

FIGURE 1.28. Collapsible 2-framed simplicial complexes with their framed 2-collapse maps.

EXAMPLE 1.2.33 (Non-collapsible framings). In Figure 1.29, we depict four 1-framed simplicial complexes which are not collapsible. In the first case, the highest frame number is 0, but the complex is not a point. In the second case, the framed 1-collapse is two points, and so the complex is not inductively collapsible. In the third and fourth cases, the complex does framed 1-collapse to a point, but fails the flow uniqueness condition.

Similarly, none of the 2-framed complexes in Figure 1.26 are collapsible: the first complex fails the flow uniqueness condition; the second fails the flow existence condition; the third is not inductively collapsible (it admits

a framed elementary 2-collapse to a complex with highest frame number 1, but that complex is not frame collapsible); and the fourth admits no framed elementary 2-collapse.

In Figure 1.30, we show two more framed 2-complexes which are not collapsible. The first complex fails flow uniqueness: the circled 1-simplex is a face of two distinct 2-simplices, each having a 2-frame vector with initial vertex in the 1-simplex. The second complex admits no framed elementary 2-collapse. In fact, these two 2-framed complexes have a common unordered simplicial complex, which admits no collapsible 2-framing at all. \square

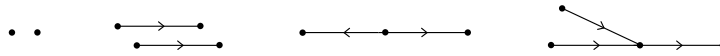

FIGURE 1.29. Non-collapsible 1-framed simplicial complexes.



FIGURE 1.30. Non-collapsible 2-framed simplicial complexes.

NOTATION 1.2.34 (Category of collapsible framings). We will denote by CollFrSimpCplx_n the full subcategory of FrSimpCplx_n , consisting of collapsible framed simplicial complexes and their framed simplicial maps. \square

REMARK 1.2.35 (Contractibility of collapsible framed complexes). Framed collapsible framed simplicial complexes are contractible. Indeed, by definition such a complex admits a sequence of framed elementary collapses eventually ending in a point, and each such elementary collapse is a simple homotopy equivalence. \square

1.2.2.2. Progressive framings. Though our primary attention will be on framed complexes that are altogether collapsible, we briefly mention the class of framed complexes that are just locally collapsible. The resulting notion of *framed progressivity* is a combinatorial analog of classical tangential frameability.

TERMINOLOGY 1.2.36 (Stars). In a simplicial complex K , the ‘star of a vertex’ p , denoted $\text{star}(p)$, is the minimal subcomplex containing all the simplices that have p as a vertex. \square

DEFINITION 1.2.37 (Framed progressive complex). A framed simplicial complex (K, \mathcal{F}) is **framed progressive** if, for each vertex $p \in K(0)$, the restricted framing $\mathcal{F}|_{\text{star}(p)}$ on $\text{star}(p)$ is collapsible. \square

REMARK 1.2.38 (Collapsibility implies progressivity). Every framed collapsible simplicial complex is framed progressive; one might imagine this is the triviality of a global property implying a local one, but that is far from the case. The implication follows from the later complete constructive combinatorial classification of collapsible complexes in [Theorem 3.1.2](#). \square

EXAMPLE 1.2.39 (Progressive framed manifolds). In [Figure 1.31](#), we depict two progressive framings on simplicial complexes, both of which happen to be manifolds. On the left is a progressive framing on the annulus, and on the right is a progressive framing on the torus. Note that the earlier framing of the torus in [Figure 1.22](#) was not progressive, and had no progressive sub-annulus. \square

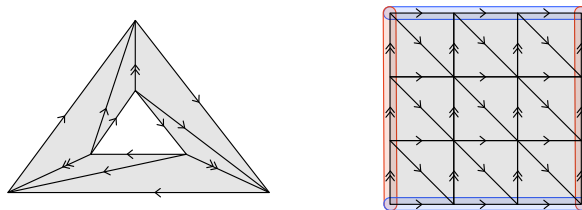

FIGURE 1.31. Progressive framed simplicial manifolds.

EXAMPLE 1.2.40 (Non-progressive framed manifolds). In [Figure 1.32](#), we depict two non-progressive framings, one on the circle and one on the Möbius band. In fact, the Möbius band admits no triangulation that has a progressive 2-framing. Another example of a non-progressive framing was the one on the 2-sphere in [Figure 1.22](#). Indeed, that complex contains as a star subcomplex the left complex in [Figure 1.30](#), which we observed was not collapsible. Again, in fact, no triangulation of the 2-sphere will have a progressive 2-framing. \square

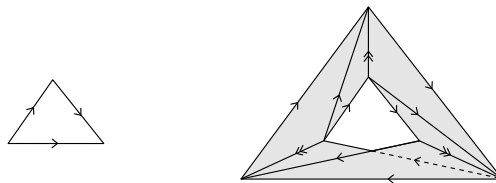

FIGURE 1.32. Non-progressive framed simplicial manifolds.

1.3. Framed regular cell complexes

Simplices are the most elementary and restrictive class of shapes from which we might assemble topological complexes. At an opposite extreme, cells, glued by arbitrary boundary maps, provide in a sense the most flexible and generalized class of shapes for constructing complexes. However, the cell boundary structures in such general cell complexes can be rather wild, and no matter their homotopical convenience, these shapes are uncombinatorializable and therefore a complete nonstarter for a computable topological theory. The minimal sane restriction is to the class of regular cells complexes, i.e. those cell complexes for which all the attaching maps are injective; regular cell complexes admit a completely combinatorial model as posets for which the links of cells are spherical.

Similarly, framed simplices provide the smallest class of shapes for a theory of framed topological complexes, and by contrast framed cells will provide the largest reasonable class of shapes for such a theory. As we saw in the previous section, a framed simplicial complex is of course a simplicial complex with compatible framings on each of its simplices. Those framings amount to a suitable positioning of the simplices with respect to the frame structure of an implicit ambient euclidean space, and consequently induce a local combinatorial flow in all the frame directions. Analogously, a *framed regular cell complex* will be a regular cell complex with compatible framings on each of its cells. Those framings provide, informally, a positioning of each cell in a framed euclidean space, and hence a locally foliating flow in each frame direction. An example of a framed regular cell complex is illustrated on the left in [Figure 1.33](#); each cell is equipped with a single central arrow indicating (by the number of arrowheads) the dominant frame direction of the cell.

The notion of framing of a regular cell complex is made precise via the notion of framing of a simplicial complex, as follows. A regular cell complex has an associated simplicial complex, namely the unordering of the nerve of the face poset of the cell complex. For example, in the figure, the associated simplicial complex of the given cell complex is illustrated on the right. The simplices of the simplicial complex are naturally grouped according to which cell of the cell complex they assemble into. For a framing of the simplicial complex to constitute a framing of the cell complex, we need to insist the framings of the simplices within a cell are suitably uniform; that uniformity is ensured by a local collapsibility condition. By definition then, a framing of a regular cell complex is a framing of the associated simplicial complex, that is collapsible on each cell. For instance, in the figure, the simplicial framing indicated on the right is indeed collapsible on each simplicial subcomplex associated to a cell, and altogether corresponds to the cellular framing indicated on the left.

OUTLINE. In [Section 1.3.1](#), we reconsider classical regular cell complexes as cellularly stratified spaces, and recall an attendant combinatorial model

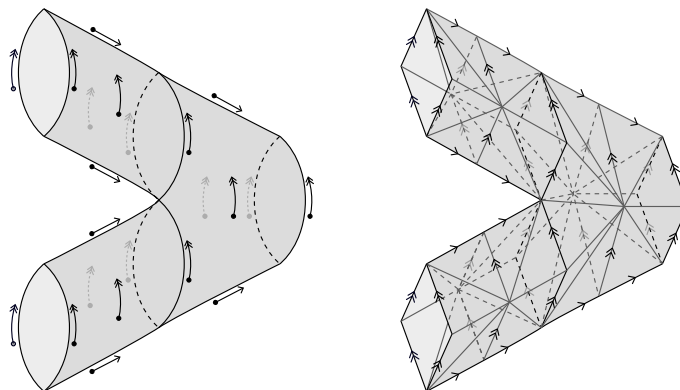

FIGURE 1.33. A framed regular cell complex and its corresponding framed simplicial complex.

of regular cell complexes as cellular posets. In Section 1.3.2, we define framed regular cell complexes as combinatorial regular cell complexes with a framing on an underlying simplicial complex, that is collapsible on each cell; we illustrate such framed cell complexes, introduce their framed cellular maps, observe they generalize framed simplicial complexes, and discuss their attractive computability properties.

1.3.1. Regular cell complexes.

SYNOPSIS. We reconsider the classical notion of regular cell complexes from the perspective of stratified spaces, and recall the corresponding combinatorial notion of cellular posets, which we will pointedly refer to as combinatorial regular cell complexes. We then describe cellular maps of regular cell complexes and of combinatorial regular cell complexes, and mention the functors taking a combinatorial regular cell complex to the underlying simplicial complex, and conversely taking a simplicial complex to the face poset combinatorial regular cell complex.

1.3.1.1. Regular cell complexes as cellular posets. Traditionally, a regular cell complex is defined as a CW complex for which the attaching maps are injective [LW69]. We adopt a somewhat different perspective, in terms of the resulting cellular stratifications, in anticipation of the attendant purely combinatorial model of cellular posets.

Recall, a stratified space, also called simply a stratification, is a space equipped with a suitable decomposition into disjoint subspaces called strata (see Definition B.1.8 and surroundings). For any stratified space, there is an associated poset (namely the fundamental poset) encoding the boundary relationships among the strata, as follows.

TERMINOLOGY 1.3.1 (Fundamental posets of stratifications). Each stratified space has an associated ‘fundamental poset’, whose elements are its strata and which has a generating arrow $s \rightarrow t$ whenever the closure of

the stratum s intersects the stratum t . (The definition of a stratified space includes the assumption that there are no cycles in that closure–intersection relation.) —

Conversely, for any poset, there is an associated stratified space (namely the stratified realization) encoding the poset arrows as boundary relationships of strata, as follows.

TERMINOLOGY 1.3.2 (Upper and strict upper closures). Given a poset P and an element $x \in P$, the ‘upper closure’ $P^{\geq x}$ is the full subposet of objects $y \in P$ with $y \geq x$; similarly, the ‘strict upper closure’ $P^{>x}$ is the full subposet of objects $y \in P$ with $y > x$. —

TERMINOLOGY 1.3.3 (Nerve and realizations of posets). Recall the ‘nerve’ NP of a poset P is the ordered simplicial complex whose k -simplices are the chains of arrows of length k in the poset. The ‘geometric realization’ $|P|$ of a poset P is the usual geometric realization of the nerve NP . —

CONSTRUCTION 1.3.4 (Stratified realizations of posets). Given a poset P , the **stratified realization** $\|P\|$ is the stratification of the geometric realization $|P|$, whose strata are the complements $\text{str}(x) := |P^{\geq x}| \setminus |P^{>x}|$ of the strict upper closures in the upper closures, for every element $x \in P$. —

The strata of the stratified realization of the poset P may alternatively be described in terms of the ordered simplicial complex NP , as follows: for each 0-simplex $x \in NP$, the stratum $\text{str}(x)$ is the union of the interiors of the geometric realizations of those simplices whose minimal vertex is x ; that union is called the ‘open star’ of the vertex.

Recall that a stratified map of stratified spaces is a map of underlying spaces that sends strata of the domain into strata of the codomain. Of course, for any stratified map, there is an associated a map of fundamental posets. Conversely, a map of posets has an associated stratified map of stratified realizations.

CONSTRUCTION 1.3.5 (Stratified realizations of poset maps). Given a poset map $F : P \rightarrow Q$, the **stratified map realization** $\|F\| : \|P\| \rightarrow \|Q\|$ is the stratified map sending each 0-simplex $x \in |P|$ to the 0-simplex $F(x) \in |Q|$, and extending linearly to all other simplices. —

Note that as a map of spaces, the stratified map realization $\|F\|$ is simply the usual geometric realization map $|F|$. (See [Constructions B.1.52](#) and [B.2.14](#) for an alternative description of stratified realizations and stratified map realizations, in terms of convex combinations of poset elements.)

We will have immediate need of the following two mild reasonableness assumptions on stratifications.

TERMINOLOGY 1.3.6 (Local finiteness; see [Definition B.1.22](#)). A stratification is ‘locally finite’ when every stratum has an open neighborhood that is the union of finitely many strata. —

TERMINOLOGY 1.3.7 (Frontier-constructibility; see Definition B.1.25). A stratification is ‘frontier-constructible’ when the closure of every stratum is a union of strata. \square

With the notions of stratified spaces at hand, we can introduce regular cell complexes, as follows.

DEFINITION 1.3.8 (Regular cell complexes). A **regular cell complex** is a locally finite, frontier-constructible stratified space, in which every stratum is an open disk and in which the closure of every stratum is a closed disk. \square

The strata of a regular cell complex are referred to as the ‘open cells’ of the complex, and the closures of the strata are referred to as the ‘closed cells’ of the complex.

EXAMPLE 1.3.9 (Regular cells). In Figure 1.34 we illustrate a few 2-dimensional and 3-dimensional regular cell complexes; these happen to be regular cells in the sense that they each have exactly one cell of maximal dimension. \square

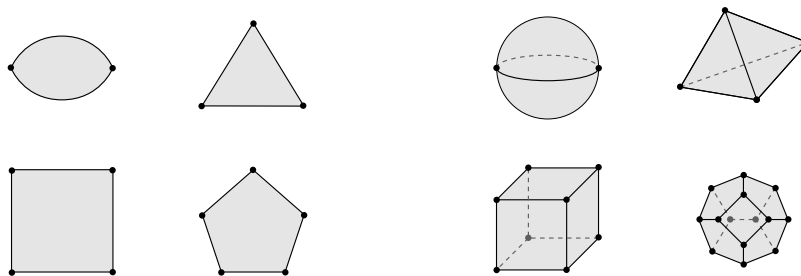

FIGURE 1.34. Regular 2-cells and regular 3-cells.

NOTATION 1.3.10 (Fundamental posets of regular cell complexes). The fundamental poset $\sqcap X$ of a regular cell complex X has an object x for each open cell of the complex, and an arrow $x \rightarrow y$ whenever the closed cell \bar{x} contains the cell y . \square

The fundamental poset is the *opposite* category of the classical ‘face poset’ of a regular cell complex, cf. [Bjö84, Bjö95]. (See Remark B.1.15 for an explanation of our choice of variance here.) Every fundamental poset $\sqcap X$ of a regular cell complex X is graded by dimension, in the sense that there is a functor $\dim : \sqcap X \rightarrow \mathbb{N}^{\text{op}}$, with discrete preimages, sending each cell to its dimension.

TERMINOLOGY 1.3.11 (Maps of regular cell complexes). A ‘map of regular cell complexes’ is simply a map of stratified spaces; in particular the image of every open cell is contained in an open cell. \square

REMARK 1.3.12 (Functoriality of fundamental posets). For regular cell complexes X and Y , and any map of regular cell complexes $F : X \rightarrow Y$, there is a functorially associated poset map $\mathbb{N}(F) : \mathbb{N}(X) \rightarrow \mathbb{N}(Y)$, taking each open cell $x \subset X$ to the open cell $y \subset Y$ containing the image $F(x)$. \square

We now describe the class of posets that can be obtained as fundamental posets of regular cell complexes. (See Terminology B.1.23 for the notion of local finiteness for posets.)

DEFINITION 1.3.13 (Cellular posets). A **cellular poset** is a locally finite poset (X, \leq) , for which the geometric realization $|X^{>x}|$ of the strict upper closure of any element $x \in X$ is homeomorphic to a sphere. \square

EXAMPLE 1.3.14 (Cellular and non-cellular posets). In Figure 1.35 we depict three cellular posets, while in Figure 1.36 we depict three posets that fail to be cellular. (For simplicity, we only draw the generating arrows of the posets.) Note that even when the upper closures $P^{\geq x}$ realize to topological balls, it need not be the case that the strict upper closures $P^{>x}$ realize to topological spheres. \square

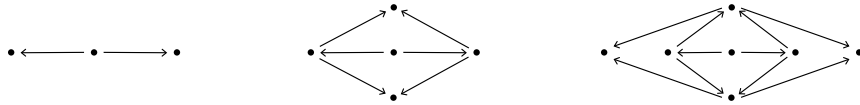

FIGURE 1.35. Cellular posets.

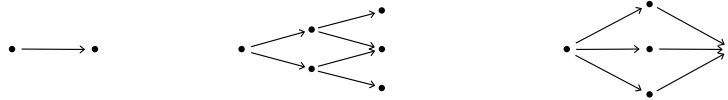

FIGURE 1.36. Non-cellular posets.

PROPOSITION 1.3.15 (Correspondence of regular cell complexes and cellular posets). *The fundamental poset and stratified realization constructions provide a precise correspondence between regular cell complexes and cellular posets, in the following sense:*

- (1) *The fundamental poset of a regular cell complex is a cellular poset.*
- (2) *The stratified realization of a cellular poset is a regular cell complex.*
- (3) *Every regular cell complex X is stratified homeomorphic to the stratified realization of its fundamental poset, i.e. $X \cong \|\mathbb{N}X\|$.¹⁰*
- (4) *Every cellular poset X is canonically isomorphic to the fundamental poset of its stratified realization, i.e. $X \cong \mathbb{N}\|X\|$.*

¹⁰The isomorphism is canonical up to stratified homotopy.

PROOF. Note that the fundamental poset of a locally finite stratification is a locally finite poset, and the stratified realization of a locally finite poset is a locally finite, frontier-constructible stratification. That the regularity condition on a cell complex implies the cellularity condition on its fundamental poset, and that the cellularity condition on a poset implies the regularity condition on its stratified realization, and that stratified realization and fundamental poset are inverse operations in the indicated sense, are all discussed in [Bjö84, §3]. \square

We conceive of this correspondence between regular cell complexes (up to stratified homeomorphism) and cellular posets, as a *combinatorialization* of regular cell complexes by cellular posets. We emphasize this viewpoint by introducing the following terminology.

TERMINOLOGY 1.3.16 (Combinatorial complexes). Henceforth, we use the term ‘combinatorial regular cell complex’ as an unequivocal synonym for ‘cellular poset’. \square

When contrasting ordinary regular cell complexes with combinatorial regular cell complexes, we may refer to the former as ‘geometric regular cell complexes’. However, eventually we will entirely elide the distinction and use ‘regular cell complex’ to mean either combinatorial regular cell complex or geometric regular cell complex, as context and perspective warrants.

Recall that the depth of an object x in a poset is the maximal length m of a chain $x = x_0 \rightarrow x_1 \rightarrow \cdots \rightarrow x_m$ beginning at that object. In light of the above complex–poset correspondence, we adopt the following geometric terminology in the combinatorial context.

TERMINOLOGY 1.3.17 (Combinatorial cells, dimension, closures, boundaries). An element x of a cellular poset X is called an ‘ m -cell’ or a cell ‘of dimension m ’, when it is of depth m . The upper closure $X^{\geq x}$ is called simply the ‘closure’ of the cell x , and the strict upper closure $X^{>x}$ is called the ‘boundary’ of the cell x .

When the cellular poset X has an initial object \perp_X , which is an m -cell, the whole complex is called a ‘combinatorial regular m -cell’ (or even just a ‘regular m -cell’ when no material confusion will arise). \square

1.3.1.2. Cellular maps of regular cell complexes. We consider a suitable class of maps of regular cell complexes, as follows.

TERMINOLOGY 1.3.18 (Closure preserving maps of stratified spaces). A stratified map is ‘closure preserving’ when it sends the closure of each stratum *onto* the closure of a stratum. \square

DEFINITION 1.3.19 (Cellular maps of regular cell complexes). A **cellular map of regular cell complexes** is a stratified map between (geometric) regular cell complexes that is closure preserving.¹¹ \square

¹¹Cellular maps in this sense have also been called ‘regular cellular maps’ in the context of not necessarily regular cell complexes [LW69]. We omit the specification ‘regular’

NOTATION 1.3.20 (The category of geometric regular cell complexes). We will denote the category of (geometric) regular cell complexes and their cellular maps by $\text{CellCplx}^{\mathcal{S}}$. —

The decoration \mathcal{S} serves to indicate the objects are in fact stratified spaces, and will be omitted in a moment when we shift attention to the corresponding combinatorial category.

We may now extend the combinatorialization of regular cell complexes to cellular maps.

TERMINOLOGY 1.3.21 (Closure preserving maps of posets). A map of posets $F : P \rightarrow Q$ is ‘upper-closure preserving’ when it sends each upper closure $P^{\geq x}$ onto the upper closure $F(P^{\geq x}) = Q^{\geq F(x)}$. —

DEFINITION 1.3.22 (Cellular maps of cellular posets). A **cellular map of cellular posets** is a poset map between cellular posets that is upper-closure preserving. —

NOTATION 1.3.23 (The category of combinatorial regular cell complexes). We will denote the category of combinatorial regular cell complexes (i.e. cellular posets) and their cellular maps by CellCplx . —

EXAMPLE 1.3.24 (Cellular and non-cellular maps). In Figure 1.37 we depict (on the left) two cellular maps of regular cells, along with (on the right) the corresponding maps of cellular posets. In each case we indicate the map by coloring images and preimages in the same color.

In Figure 1.38, we depict two maps of regular cells that are cellular maps of cell complexes in the classical sense but are not cellular maps of regular cell complexes in our present sense; alongside each is the corresponding non-cellular map of cellular posets. —

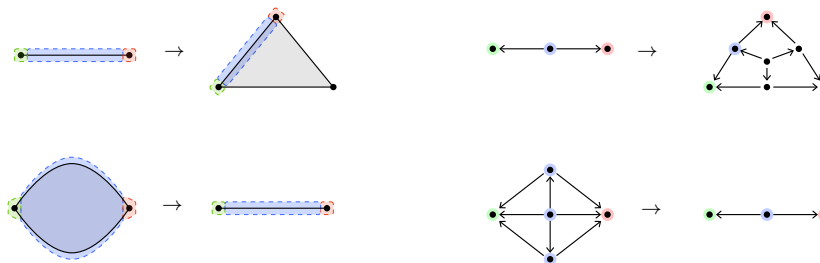

FIGURE 1.37. Cellular maps of regular cells.

because we are restricting attention to maps of regular cell complexes; note then that our notion of cellular maps of regular cell complexes is much more restrictive than the classical notion of cellular maps of cell complexes.

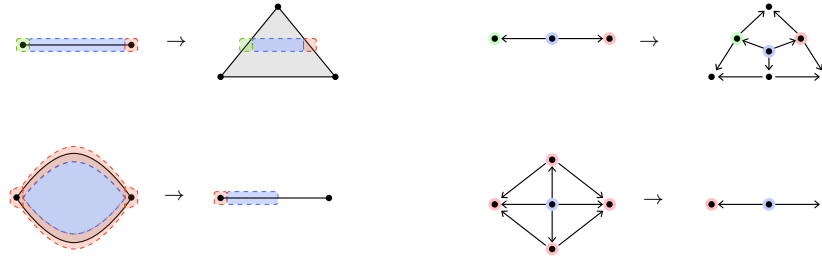

FIGURE 1.38. Non-cellular maps of regular cells.

OBSERVATION 1.3.25 (Translation functors for regular cell complexes). The fundamental poset construction (see Notation 1.3.10 and Remark 1.3.12), and the stratified realization construction (see Construction 1.3.4 and Construction 1.3.5), provide functors

$$\text{CellCplx}^{\mathcal{S}} \begin{array}{c} \xrightarrow{\sqcap} \\ \xleftarrow{\|\cdot\|} \end{array} \text{CellCplx} \quad \text{—} \sqcup$$

REMARK 1.3.26 (The equivalence of geometric and combinatorial regular cell complexes). One may just accept cellular posets as a reasonable, faithful combinatorial substitution for regular cell complexes, or to make precise a comparison between the geometric and combinatorial notions of regular cell complexes, proceed as follows.

Restricting attention to locally finite stratifications and locally finite posets, the fundamental poset construction yields a functor of *topologically enriched* categories $\sqcap : \text{Strat}_{\text{lf}} \rightarrow \mathcal{P}os_{\text{lf}}$ (see Construction B.2.20). Denote by $\text{CellCplx}^{\mathcal{S}}$ the topologically enriched subcategory of Strat_{lf} , given by geometric regular cell complexes and their cellular maps. Similarly consider the (a priori topologically enriched) subcategory of $\mathcal{P}os_{\text{lf}}$, given by combinatorial regular cell complexes and their cellular maps; due to the cellularly condition on maps, that subcategory has discrete hom-spaces, and so is identical to the ordinary category CellCplx .

The fundamental poset functor $\sqcap : \text{CellCplx}^{\mathcal{S}} \rightarrow \text{CellCplx}$ is a *weak equivalence* of topologically enriched categories; we leave that assertion without proof (and will not rely upon it). In particular, the space of cellular maps between any two geometric regular cell complexes is homotopically discrete. $\text{—} \sqcup$

Recall the stratified realization $\|\cdot\|$ of a cellular poset P is the stratification of the geometric realization of the nerve NP (considered as an ordered simplicial complex), by the open stars of the vertices. In light of the functorial correspondence between regular cell complexes and cellular posets, via the fundamental poset and the stratified realization, we now have in fact three interchangeable representations of any given cellular poset, namely as the

poset P , the ordered simplicial complex NP , and the stratified space $\|P\|$. We therefore shift freely between these perspectives, and permit the following stark abuse of notation.

NOTATION 1.3.27 (Regular cell complexes). We will conceive of, refer to, and illustrate a combinatorial regular cell complex variously as follows:

- > As a cellular poset $X \in \text{CellCplx}$.
- > As an ordered simplicial complex $NX \in \text{SimpCplx}^{\text{ord}}$.
- > As a regular cell complex $X \in \text{CellCplx}^{\mathcal{S}}$.

In particular, we actively suppress the stratified realization notation by writing $\|X\| \in \text{CellCplx}^{\mathcal{S}}$ as simply X . We tend to flag the ordered simplicial complex representation as the nerve NX , but even there we may drop the nerve designation and call it simply X . These abuses apply similarly to maps of combinatorial regular cell complexes, wherein the notation $F : X \rightarrow Y$ may refer to a map of cellular posets, of ordered simplicial complexes, or of regular cell complexes, as context entails. —

EXAMPLE 1.3.28 (Representations of regular cell complexes). In Figure 1.39 we illustrate a geometric regular cell complex X (on the left), together with its corresponding cellular poset X (in the middle), and its ordered simplicial complex NX (on the right). We represent the ordering on that simplicial complex by small blue arrows emanating from the vertices, in order to make room for later framing notations. —

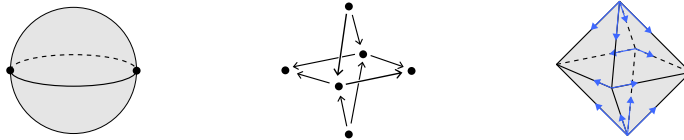

FIGURE 1.39. A geometric regular cell complex and its corresponding cellular poset and ordered simplicial complex.

TERMINOLOGY 1.3.29 (Underlying simplicial complexes of regular cell complexes). Given a combinatorial regular cell complex i.e. cellular poset X , the nerve NX is an ordered simplicial complex, and the unordering $(NX)^{\text{un}}$ is of course an unordered simplicial complex. We call that last complex the ‘underlying simplicial complex’ of the combinatorial regular cell complex. Of course, this association $(N-)^{\text{un}} : \text{CellCplx} \rightarrow \text{SimpCplx}$, of the underlying simplicial complex to a combinatorial regular cell complex, is functorial. We may further abuse notation by referring to the underlying simplicial complex $(NX)^{\text{un}}$ simply as X , as convenient. —

A combinatorial regular cell complex has an underlying simplicial complex; conversely, a simplicial complex may be interpreted as a combinatorial regular cell complex, as follows.

CONSTRUCTION 1.3.30 (Simplicial complexes as combinatorial regular cell complexes). For a simplicial complex K , define its ‘face poset’ $\mathbb{F}K$ to be the poset whose objects are the simplices x of the complex, with a morphism $x \rightarrow y$ whenever the simplex y is a face of the simplex x .¹² For a simplicial map of simplicial complexes $F : K \rightarrow L$, define a map of face posets $\mathbb{F}F : \mathbb{F}K \rightarrow \mathbb{F}L$ by sending a simplex $x \in K$ to the simplex $F(x) \in L$. Together these associations yield a ‘face poset functor’, in fact a fully faithful embedding, from simplicial complexes to combinatorial regular cell complexes:¹³

$$\mathbb{F} : \text{SimpCplx} \hookrightarrow \text{CellCplx} \quad \text{—}$$

This inclusion of combinatorial simplicial complexes in combinatorial regular cell complexes has an obvious geometric counterpart: geometric simplicial complexes are certainly geometric regular cell complexes, whose closed cells happen to be closed simplices.

Note well that considering a simplicial complex as a cell complex, via its face poset, is by no means inverse to considering the underlying simplicial complex of a cell complex; indeed the composite of those processes is a subdivision, as follows.

TERMINOLOGY 1.3.31 (Barycentric subdivision of regular cell complexes). Given a combinatorial regular cell complex X , its ‘barycentric subdivision’ is the combinatorial regular cell complex $\mathbb{F}((NX)^{\text{un}})$, obtained as the face poset of the unordering of the nerve of the cellular poset X . There is a map of posets $\mathbb{F}((NX)^{\text{un}}) \rightarrow X$ sending an object $(x_0 \rightarrow \cdots \rightarrow x_k) \in \mathbb{F}((NX)^{\text{un}})$ to the object $x_0 \in X$. The stratified realization of that map is a stratified map $\|\mathbb{F}((NX)^{\text{un}})\| \rightarrow \|X\|$ of regular cell complexes from the geometric barycentric subdivision to the original geometric complex; though not a homeomorphism of spaces, that map is stratified homotopic to a coarsening (see Definition B.2.4), which we regard as a ‘geometric barycentric subdivision’. —

Recall that in the definition of regular cell complexes appears the innocuous sounding but actually rather treacherous condition that the strata are, i.e. are homeomorphic to, disks; correspondingly in the definition of cellular posets appears the condition that the realizations of the strict upper closures are homeomorphic to spheres. The appearance of those homeomorphism conditions compels us to distinguish ‘topological cellular’ structures from ‘piecewise linear cellular’ structures (whether geometrically or combinatorially considered), as follows.

¹²The variance here is chosen to align with our conventions for fundamental posets.

¹³Notice that if we enlarged the target to allow non-cellular maps of cellular posets, this functor would no longer be fully faithful.

DEFINITION 1.3.32 (PL cellular posets). A **PL cellular poset** is a locally finite poset (X, \leq) , for which the geometric realization $|X^{>x}|$ of the strict upper closure of any element $x \in X$ is piecewise linearly homeomorphic to the standard piecewise linear sphere [Hud69, §I.5]. \square

This distinction is material, as the following remark emphasizes.

REMARK 1.3.33 (Cellular complexes need not be PL cellular). Though of course a PL cellular poset is a cellular poset, the converse is not the case, i.e. there are regular cells whose boundary is not a standard piecewise linear sphere. Indeed, there are triangulations of spheres that are not piecewise linearly homeomorphic to standard piecewise linear spheres (see [Edw80], [Bry02, Thm. 9.1]); adjoining a minimal element to the fundamental poset of such a triangulation yields a poset that is cellular but not PL cellular. By contrast, eventually we will find that framed cellular complexes are necessarily framed PL cellular. \square

1.3.2. Framings on regular cell complexes.

SYNOPSIS. We define framed regular cell complexes as combinatorial regular cell complexes with a framing on the underlying simplicial complex that is collapsible on each cell. We then provide various examples of framed regular cells, utilizing a trio of illustrative notations, namely as ordered framed simplicial complexes, as ordered realized simplicial complexes, and as realized cell complexes. We observe that the highest frame vectors of a framed regular cell form a single axel vector, and define framed cellular maps as those cellular maps preserving or degenerating every axel vector. Next we mention that framed simplicial complexes can be interpreted as framed regular cell complexes via a framed face poset construction. Finally, we discuss the computable tractibility, specifically the enumerability, recognizability, and piecewise linearity, of framed regular cells, and conclude by introducing the notion of n -directed acyclic graphs as those n -framed regular cell complexes that admit a framed realization to euclidean space.

1.3.2.1. The definition of framed regular cell complexes. A combinatorial regular cell complex can be represented by its ordered simplicial complex (obtained as the nerve of the cellular poset); the ordering keeps track of which groups of simplices fit together into each cell of the cell complex. Conceptually, a framing of a combinatorial regular cell complex should consist of a frame structure on each cell (compatible with boundaries, of course). Definitionally, that frame of a cell will be specified as a framing of the underlying simplicial complex of the cell; we ensure that the framing is suitably uniform across the simplices within a cell, by insisting the framing of each cell is collapsible.

Though framed combinatorial regular cell complexes may be considered as gluings of their individual framed combinatorial regular cells, there is no economy in defining framings cell by cell rather than all at once, as follows.

DEFINITION 1.3.34 (Framed regular cell complex). An n -framing \mathcal{F} of a combinatorial regular cell complex X is an n -framing \mathcal{F} of the underlying simplicial complex, such that, for each cell $x \in X$, the restriction $\mathcal{F}|_{X^{\geq x}}$ is a collapsible framing on the closed cell $X^{\geq x}$. \square

We refer to a combinatorial regular cell complex X together with an n -framing \mathcal{F} as an ‘ n -framed regular cell complex’ (X, \mathcal{F}) ; that is, in the framed context we expressly drop the word ‘combinatorial’ from the terminology. Similarly, we refer to a combinatorial regular cell with a framing as a ‘framed regular cell’. Furthermore, we refer to the underlying simplicial complex together with the framing (i.e. having forgotten the nerve order coming from the cellular poset) as the ‘underlying framed simplicial complex’.

REMARK 1.3.35 (The two orders of a framed regular cell complex). To forestall confusion, we emphasize that the underlying simplicial complex of a framed regular cell complex has two distinct orders, namely the one obtained by taking the nerve of the cellular poset, and the one induced by the framing of the underlying simplicial complex. \square

EXAMPLE 1.3.36 (A 2-framed regular cell complex). In Figure 1.40 we depict the data of a framed regular cell complex (X, \mathcal{F}) , as follows. On the left, we show a combinatorial regular cell complex X , represented as its ordered simplicial complex NX ; as in Example 1.3.28, the order is indicated by blue arrows with solid heads. On the right, we show a framing \mathcal{F} of the underlying simplicial complex $(NX)^{un}$; as in Example 1.1.25, the frame labels are record by a multi-headed arrow notation. In the middle, the structures are merged into a single picture containing all the data of the framed cell complex.

In Figure 1.41 we illustrate the verification that this particular combination of order and framing indeed provides a framed regular cell complex. In the middle, we highlight four cells $x \in X$ (two 1-dimensional and two 2-dimensional), and on the left and right depict the framed simplicial subcomplexes obtained by restricting the framing \mathcal{F} to the closed cells $X^{\geq x} \hookrightarrow X$. In each case, the framing is collapsible, as required. \square

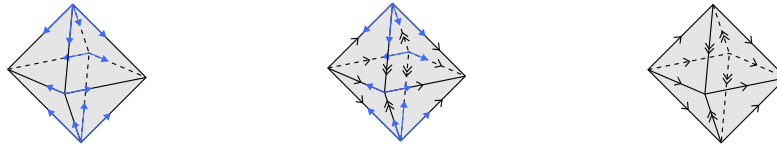

FIGURE 1.40. A 2-framed regular cell complex.

TERMINOLOGY 1.3.37 (Framed realizations of framed regular cell complexes). A ‘framed realization’ of an n -framed regular cell complex (X, \mathcal{F}) is a framed realization $|X| \rightarrow \mathbb{R}^n$ of the underlying framed simplicial complex

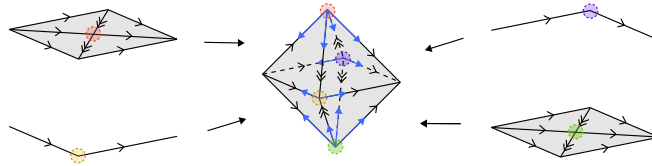

FIGURE 1.41. Collapsible subcomplexes of a 2-framed regular cell complex.

(in the sense of Definition 1.2.14), which restricts to an embedding on each cell. —

Framed realizations provide a convenient way to illustrate framings on regular cell complexes, as follows.

EXAMPLE 1.3.38 (Framed realization of a framed regular cell complex). In Figure 1.42, on the left, we re-illustrate the framed simplicial complex from Example 1.3.36, together with a framed realization to \mathbb{R}^2 . Recall that the framing of a framed simplex is determined by a framed realization, in the sense that the frame label of a vector is the index of the positive standard component containing the corresponding translation vector; similarly the framing of a whole simplicial or cell complex is determined by a realization. Thus we could omit from the picture all the black frame arrowheads. Indeed, on the right we depict a map from the corresponding geometric regular cell complex to \mathbb{R}^2 , with no specific indication of frame vectors, but nevertheless with the understanding that this map conveys the structure of the framing; this illustration (and this method of illustration henceforth) can be considered an informal relaxation of the corresponding formal simplicial depiction.¹⁴ —

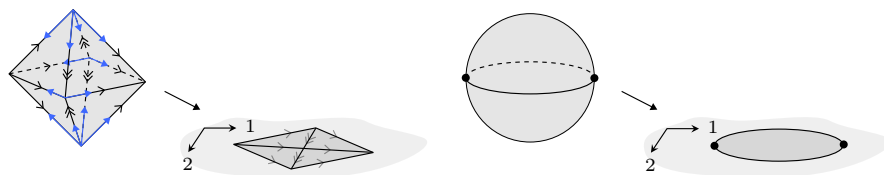

FIGURE 1.42. A 2-framed regular cell complex with a framed realization.

EXAMPLE 1.3.39 (Framed regular cell complexes via the framed realization image). When a framed realization of a framed simplicial complex is a global embedding, then the image of the realization, as a bare simplicial complex in euclidean space, contains all the framing data of the complex. Thus, when a

¹⁴In fact, the linear simplicial realization map can be reconstructed, up to contractible choice of homotopy, from the relaxed nonlinear map.

framed realization of a framed cell complex is a global embedding, to capture the framed complex we need only record the simplicial complex realization image together with the relevant grouping of those simplices into cells.

For instance, consider the front halves of the cell complex and the underlying simplicial complex in Figure 1.33. Those (half) complexes project homeomorphically into the plane of the paper; the projection of the simplicial complex provides a framed realization, and the projection of the cell complex provides a corresponding informal realization. In Figure 1.43 we depict the images of those two maps. The right image by itself encodes an underlying framed simplicial complex; the left image indicates the grouping of simplices into cells and therefore completes the encoding of a framed cell complex. However, note that the right image can be reconstructed from the left by linear barycentric subdivision; thus finally the left cell picture by itself represents a framed cell complex. —

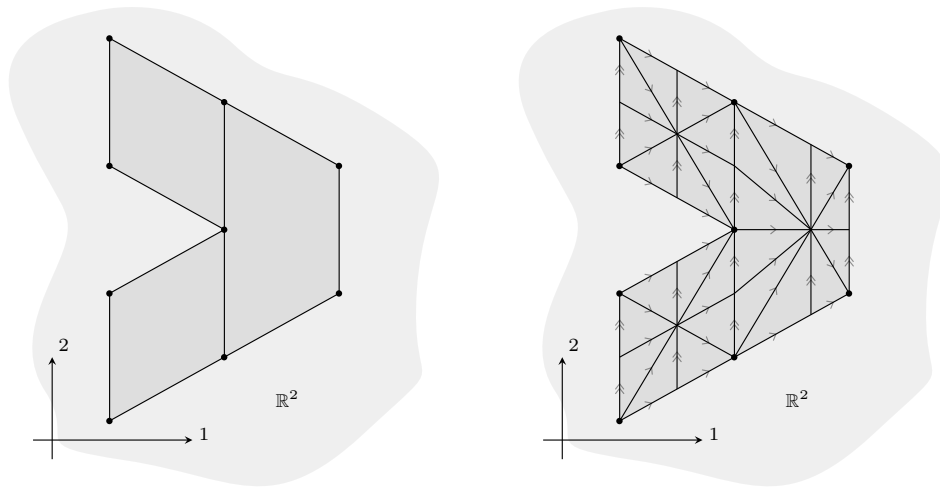

FIGURE 1.43. Framed realization of a framed regular cell complex.

By definition, a framing of a regular cell complex is a framing of the underlying simplicial complex that is framed collapsible on every closed cell subcomplex; we will be mostly concerned with framed regular cell complexes that are not just locally but in fact globally collapsible, as follows.

TERMINOLOGY 1.3.40 (Collapsible and progressive framed regular cell complexes). A framed regular cell complex (X, \mathcal{F}) is ‘framed collapsible’ when the framing \mathcal{F} of the underlying simplicial complex is framed collapsible in the sense of Definition 1.2.31. Similarly, a framed regular cell complex is ‘framed progressive’ when the framing of the simplicial complex is framed progressive in the sense of Definition 1.2.37. Usually we abbreviate these terms to simply ‘collapsible’ and ‘progressive’. —

EXAMPLE 1.3.41 (Collapsible and non-collapsible framed regular cell complexes). In Figure 1.44 we illustrate two framings of the same regular cell complex. For the left framed complex, ignoring for a moment the red arrows, the framing is determined by its framed realization, as described in Example 1.3.39. Observe that this framing is collapsible. Later, we will introduce the red arrows as ‘axel vectors’, encoding the direction of the highest frame vectors interior to the framed cells; for now we include them merely as a graphic indicator of the framed structure of some of the cells.

The right framed complex does not admit any framed realization embedding. We therefore proleptically rely on the axel vectors to convey the frame structure of all the cells. (Alternatively, consider the mutual underlying simplicial complex, take the framing from the left case, and flip the six 2-frame vectors occurring in the triangular closed 2-cell; that produces the framed simplicial complex for the right case.) Observe that this framing is not collapsible (and indeed not even progressive), since it fails the flow uniqueness condition around each of the circled 1-cells. Notice this framed regular cell complex is a coarsening of the framed simplicial complex shown in Figure 1.21. —

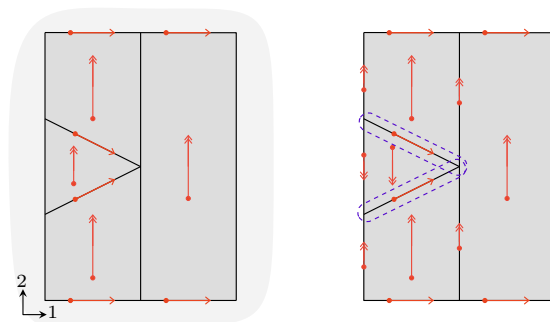

FIGURE 1.44. Collapsible and non-collapsible framed regular cell complexes.

1.3.2.2. Examples of framed regular cells.

EXAMPLE 1.3.42 (2-Framed regular 1-cells). In Figure 1.45 we illustrate two 2-framed regular 1-cells. In each case we give three distinct representations of the framed regular cell. Each picture of type ① employs the notation from Example 1.3.36, namely displaying the ordered simplicial complex (ordered by the blue arrows) along with the framing of the underlying simplicial complex (framed by the black arrowheads). Each picture of type ② displays a framed realization of the underlying framed simplicial complex, along with the ordering of that complex (encoding the grouping of simplices into cells). Each picture of type ③ displays the image of an embedding of the regular cell in euclidean space, as a schematic notation suggestive of the corresponding

second picture type. We will often depict framed regular cells simply by the third picture type, i.e. by a cell embedded in euclidean space. ┌

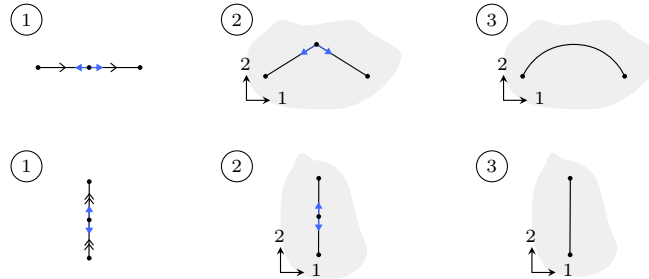

FIGURE 1.45. 2-Framed regular 1-cells.

EXAMPLE 1.3.43 (2-Framed regular 2-cells). In Figure 1.46 we illustrate four 2-framed regular 2-cells, using the same triple of picture types from the previous example. More examples of 2-framed regular 2-cells can be found in Figure C.1. ┌

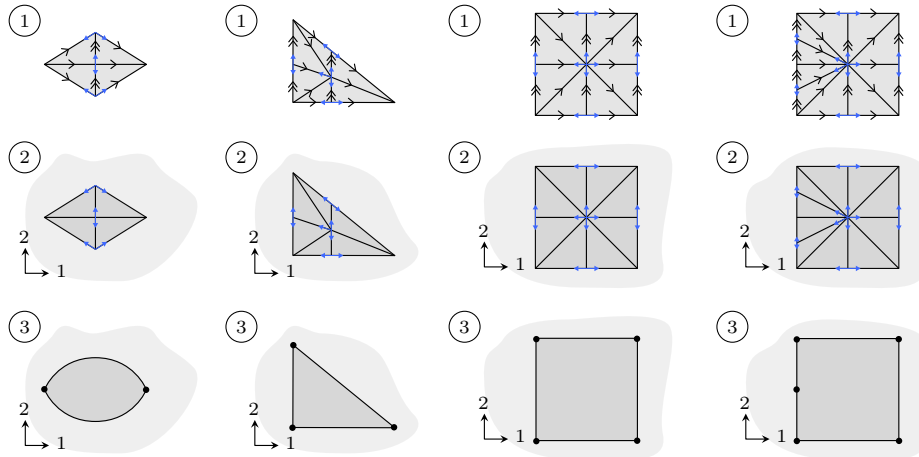

FIGURE 1.46. 2-Framed regular 2-cells.

EXAMPLE 1.3.44 (Not framed regular 1-cells). It is not the case that any picture more or less like those in the preceding examples determines a framed regular cell. In particular, one can have a regular cell, together with a framing of its underlying simplicial complex, that is not a framed regular cell, because it fails in one or another way to be collapsible on some closed subcell. For instance, in Figure 1.47 we depict two combinatorial regular 1-cells, with framings of their underlying simplicial complexes, which fail to be framed regular cells. As in the previous examples, each case is drawn in three distinct ways, and now also the location of the failure of collapsibility is circled. ┌

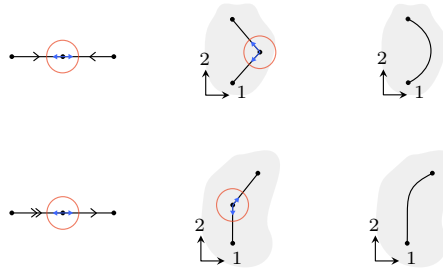

FIGURE 1.47. Framings of simplicial complexes underlying regular 1-cells that are not framed regular cells.

EXAMPLE 1.3.45 (Not framed regular 2-cells). Similarly, in Figure 1.48 we depict three combinatorial regular 2-cells, with framings of their underlying simplicial complexes, which again fail to be framed regular cells. Notice that in the first case, the framed simplicial complex of the entire closed 2-cell is collapsible, but nevertheless the restriction of the framing to each of the closed 1-cells is not collapsible. The second case is similar, in that the framing restricted to either the left or right boundary 1-cell is not collapsible. In the third case, the framed simplicial complex of the 2-cell itself is not collapsible. ┌

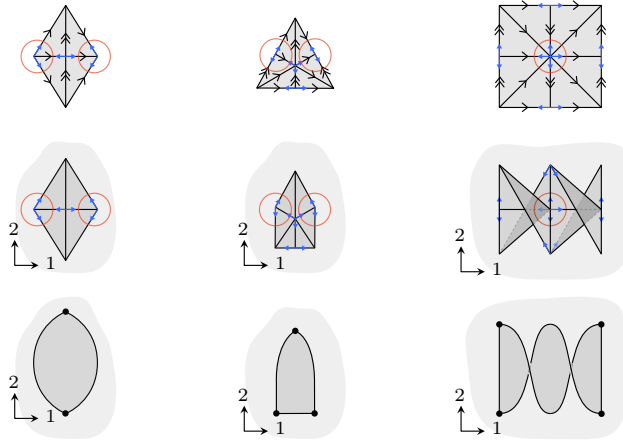

FIGURE 1.48. Framings of simplicial complexes underlying regular 2-cells that are not framed regular cells.

EXAMPLE 1.3.46 (The simplest 3-framed regular 3-cell). In Figure 1.49, we depict the 3-globe as a framed regular cell. As before, we use three parallel representations: first, as an ordered simplicial complex with a framing of the underlying simplicial complex; second, as a framed realization of the underlying simplicial complex, with an ordering; and third, as a schematic realization of the regular cell itself. ┌

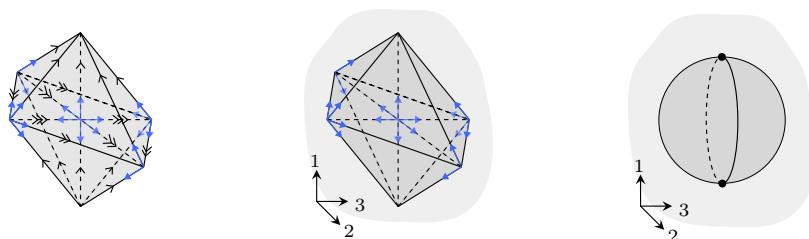

FIGURE 1.49. The simplest framed regular 3-cell.

EXAMPLE 1.3.47 (Not a framed regular 3-cell). In Figure 1.50, on the left we depict the combinatorial regular 3-cell corresponding to a 3-globe (as an ordered simplicial complex), with a framing of the underlying simplicial complex, which fails to be a framed regular 3-cell. Note well that the underlying framed simplicial complex here is identical to the underlying framed simplicial complex in Figure 1.49, but the ordering is crucially different. That ordering controls which simplices combine into the cells of the combinatorial regular cell complex, and thus how the framing interacts with those cells; though represented by tiny blue arrows, the ordering cannot be considered incidental. This framing, when restricted to any of the 1-cells or 2-cells, as indicated by the red circles, is not collapsible. On the right we depict a corresponding schematic realization of the regular cell itself, which is again essentially distinct from the schematic realization in Figure 1.49, and does not represent a framed cell. ┌

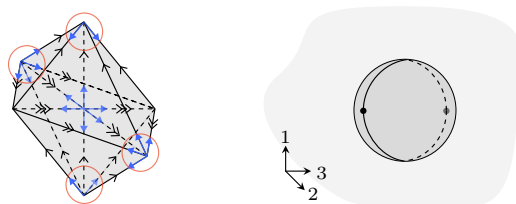

FIGURE 1.50. A framing of the simplicial complex underlying the regular 3-globe that is not a framed regular cell.

EXAMPLE 1.3.48 (Framed regular 3-cells). The previous Example 1.3.46 is of the simplest framed regular 3-cell; indeed its underlying regular cell complex is the simplest regular cell decomposition of the 3-ball. Needless to say, framed regular 3-cells can be of various other shapes. In Figure 1.51 we illustrate (using the method explained in Example 1.3.42) framings on three more regular 3-cells, namely the remaining three 3-cells previously shown in Figure 1.34. ┌

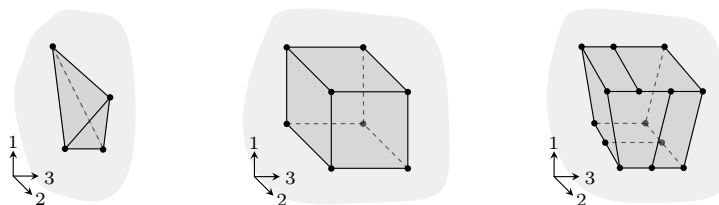

FIGURE 1.51. Simple framed regular 3-cells.

EXAMPLE 1.3.49 (Not framed regular 3-cells). In Figure 1.52 we depict two regular 3-cells, simplices in fact, embedded in euclidean space, which, though, are not the framed realizations of any framed regular cells. Consider any linear barycentric subdivision of either of these embedded cells; for the cell to be framed, the subdivided embedded simplicial complex would have to be the framed realization of a framed simplicial complex. However, notice that there is a 2-simplex of that subdivision all of whose edges have frame label 1; that is, of course, impossible for a framed 2-simplex. \square

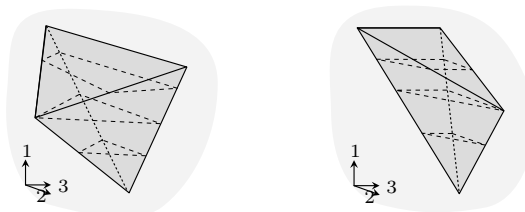

FIGURE 1.52. Realizations of regular 3-cells that are not framed regular cells.

EXAMPLE 1.3.50 (More 3-framed regular 3-cells). In Figure 1.53 we depict a few more framed regular 3-cells, and in Figure 1.54 we depict yet more, with increasingly exotic shapes. A larger and more systematic collection of framed regular 3-cells can be found in Figures C.2, C.3, C.4, and C.5. \square

EXAMPLE 1.3.51 (A more elaborate collapsible framed regular cell complex). In Figure 1.55 we depict a collapsible 3-framed regular cell complex, made up of four framed 3-cells, namely the first two framed regular 3-cells from Figure 1.54, together with a reflection of each. This complex is geometrically dual to the Hopf circle [GWZ86], as indicated by the blue curve traversing through the middle of each 3-cell, and as will be explained much later on in Example 5.2.36. \square

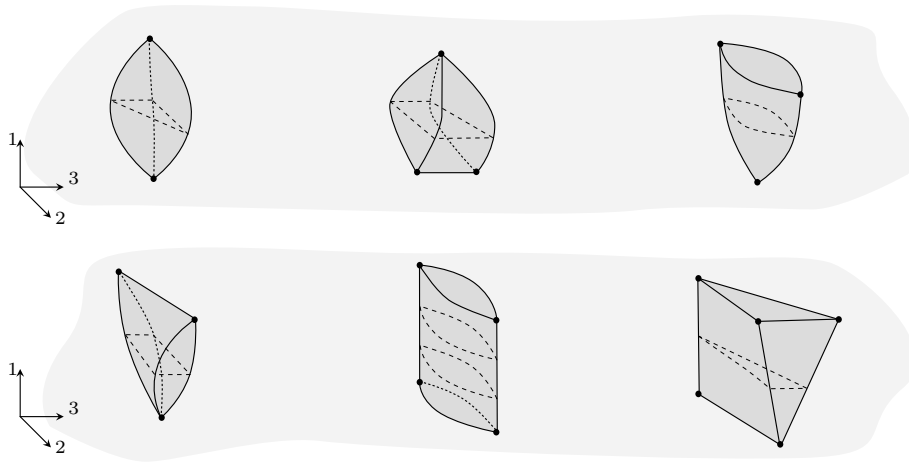

FIGURE 1.53. More framed regular 3-cells.

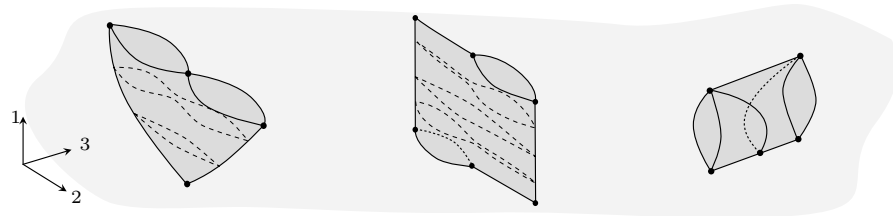

FIGURE 1.54. Yet more framed regular 3-cells.

1.3.2.3. Framed cellular maps. Recall that a framed map of a framed simplicial complex is a simplicial map that restricts to a framed map on each simplex; or, equivalently, it is a simplicial map such that, for every vector in the complex, either its frame label is preserved or the vector is degenerated. Since every vector is the highest frame vector of some simplex (if only the vector simplex itself), this notion can be rephrased yet again as a simplicial map such that, for the highest frame vector of every simplex, either its frame label is preserved or the vector is degenerated. That last formulation provides a template for the definition of framed cellular map of framed regular cell complexes, as a cellular map for which the highest frame vectors of each cell are either preserved or degenerated.

In preparing that definition, then, our first task is understanding the highest frame vectors of framed regular cells.

TERMINOLOGY 1.3.52 (Highest frame vectors of framed regular cells). Given an n -framed regular cell (X, \mathcal{F}) with initial object $x \in X$, the ‘highest frame vectors’ of the cell are those 1-simplices of the underlying framed

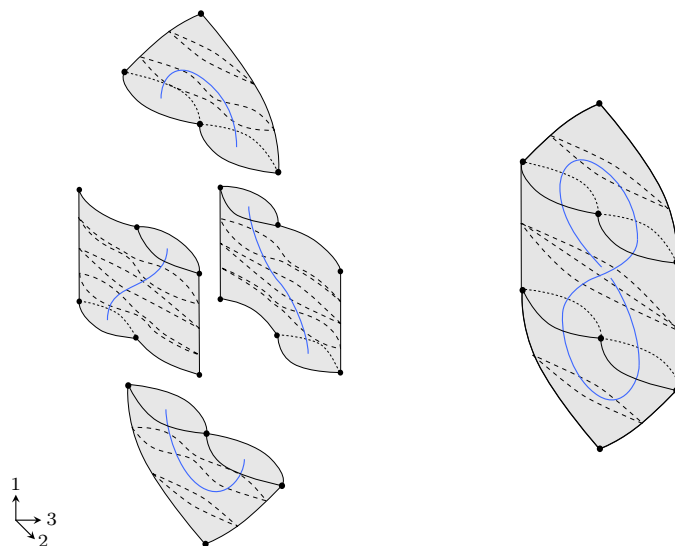

FIGURE 1.55. The framed regular cell complex dual to the Hopf circle.

simplicial complex, that contain x and whose framed labels are maximal among the frame labels of the complex.

The ‘highest frame subcomplex’ is the simplicial subcomplex consisting of the highest frame vectors. We refer to that subcomplex as the ‘axel’ or ‘axel vector’ of the cell (for reasons described presently), and denote it by $\text{axel } x$. —

REMARK 1.3.53 (The highest frame vectors form a vector). The highest frame subcomplex $\text{axel } x$ always contains exactly two vectors, and is isomorphic (with its frame order) to the linear simplicial complex $(\bullet \rightarrow \bullet \rightarrow \bullet)$; moreover, the poset order of the subcomplex is isomorphic to the 1-cell poset $(\bullet \leftarrow \bullet \rightarrow \bullet)$. In this sense, the highest frame vectors may be regarded as forming a single (cell) vector, justifying the aforementioned terminology ‘axel vector’. We will revisit and establish this claim in [Observation 3.3.16](#). —

EXAMPLE 1.3.54 (Highest frame vectors and axel vectors of framed regular cells). In [Figure 1.56](#) we illustrate the highest frame vectors and axel vectors of some framed regular 1-cells and 2-cells. In the first row, we depict the ordered framed simplicial complex (representation of the framed cell), and circle the highest frame vectors. Note that in every case, there are exactly two highest frame vectors, one ending in the initial element of the cell and one starting at the initial element of the cell. In the second row, we introduce a compact notation for this situation, by drawing a single red vector in the corresponding realized cell, representing the single axel vector of that cell. Note that the common framing label of the two highest frame vectors is indicated on the axel vector using the multi-arrowhead notation. —

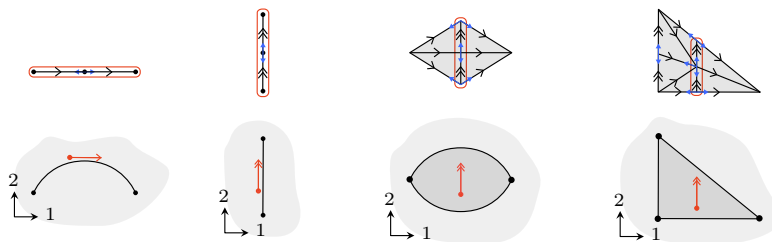

FIGURE 1.56. Highest frame vectors and axel vectors of framed regular 1-cells and 2-cells.

EXAMPLE 1.3.55 (Axel vectors of framed regular 3-cells). In Figure 1.57, we similarly depict the axel vectors of several framed regular 3-cells. We also indicate the axel vectors for selected cells on the boundary of these 3-cells. —

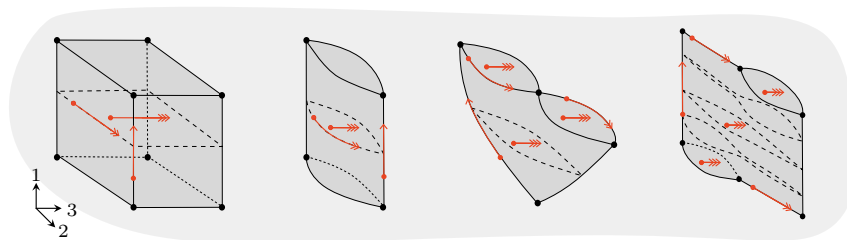

FIGURE 1.57. Axel vectors of framed regular 3-cells.

The definition of framed cellular maps of framed regular cell complexes now proceeds by analogy with that of framed simplicial maps of framed simplicial complexes, as follows.

DEFINITION 1.3.56 (Framed cellular maps of framed regular cell complexes). Consider n -framed regular cell complexes (X, \mathcal{F}) and (Y, \mathcal{G}) . A **framed cellular map** $F : (X, \mathcal{F}) \rightarrow (Y, \mathcal{G})$ is a cellular map of cellular posets $F : X \rightarrow Y$, such that for every cell $x \in X$, either its axel vector is preserved, i.e. the map restricts to a framed simplicial complex isomorphism $(\text{axel } x, \mathcal{F}|_{\text{axel } x}) \cong (F(\text{axel } x), \mathcal{G}|_{F(\text{axel } x)})$, or its axel vector is degenerated, i.e. $F(\text{axel } x)$ is a point. —

We often refer to ‘framed cellular maps’ simply as ‘framed maps’.

EXAMPLE 1.3.57 (Framed maps of framed regular cells). In Figure 1.58 we illustrate three framed maps of framed regular cells; the maps are indicated by highlighting image and preimage cells in the same color. On the left, each map is depicted via its schematic framed cellular realization; on the

right, each map is depicted as a map of ordered framed simplicial complexes. In each case, a pertinent axel vector is drawn in the relevant cell, and the corresponding highest frame vectors are circled in the corresponding simplicial complex. Notice these axel vectors are either preserved or degenerated, as required. ┌

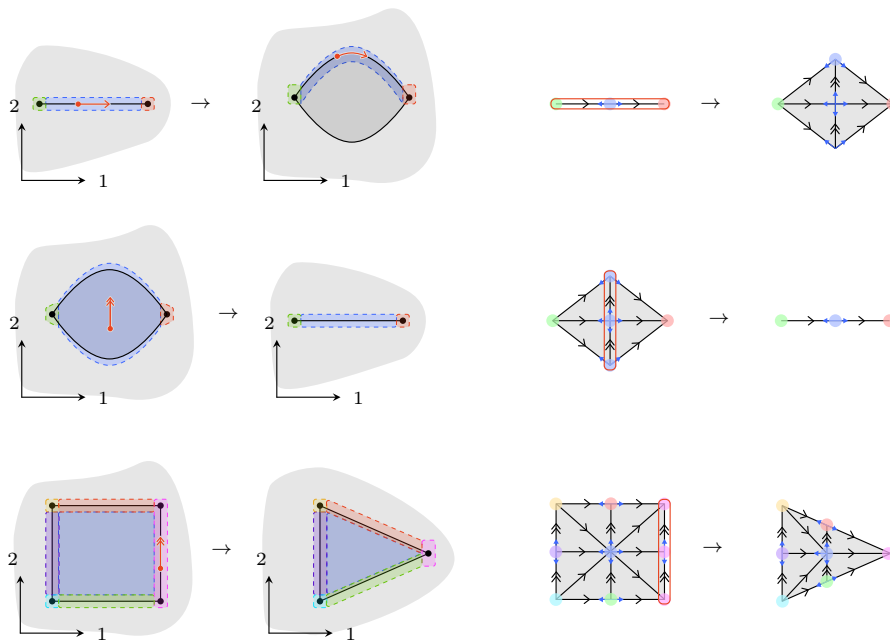

FIGURE 1.58. Framed cellular maps.

EXAMPLE 1.3.58 (Not framed maps of framed regular cells). In Figure 1.59 we similarly illustrate cellular maps of framed regular cells that are not framed maps. These maps fail to preserve the axel vector, in the required sense; in each case the failure is circled in the cell representation, as a discrepancy between the image of the axel vector of a source cell and the axel vector of a target cell. In the first case, the indicated axel 1-vector is sent to the inverse of the axel 2-vector; in the second case, the indicated axel 2-vector is sent to the inverse of the axel 2-vector; in the third case, the indicated axel 2-vector is sent to an axel 1-vector. ┌

REMARK 1.3.59 (Framed maps of cells are subframed on simplices). Note well that given a framed map of framed regular cell complexes, the underlying simplicial map is *not* a framed map of framed simplicial complexes. Instead, the natural structure of framed maps of framed cells produces *subframed* maps of the constituent framed simplices (see Remark 1.2.20); that is, the simplicial map need not preserve the frame order and it may specialize the

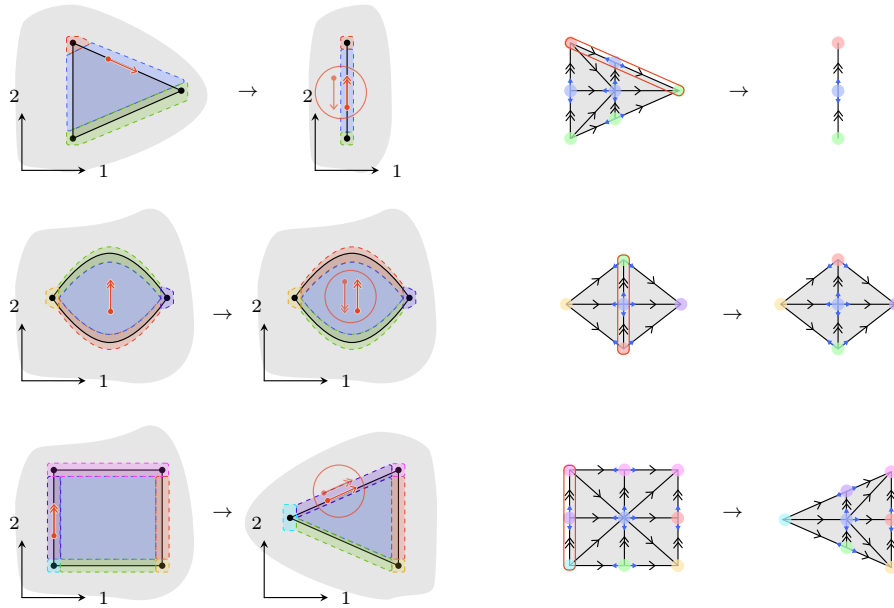

FIGURE 1.59. Cellular maps that are not framed.

frame labels. This situation is more or less the *raison d'être* for the notion of subframed simplicial maps.

In Figure 1.60 we illustrate an example of a framed map of framed cells, whose underlying simplicial map is not framed; the circled frame 1-vectors are sent to frame 2-vectors or inverse frame 2-vectors. ┌

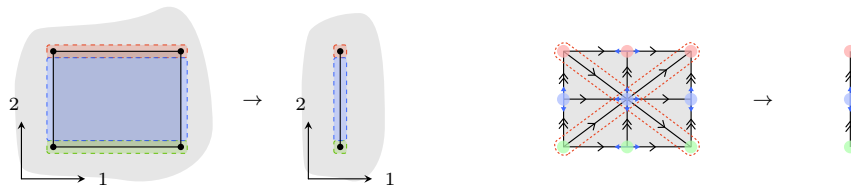

FIGURE 1.60. A framed cellular map that is subframed simplicial.

NOTATION 1.3.60 (Categories of framed regular cell complexes). We will denote the category of n -framed regular cell complexes and their framed maps by FrCellCplx_n . The full subcategory of framed collapsible n -framed regular cell complexes is CollFrCellCplx_n , and the fully subcategory of n -framed regular cells is FrCell_n . ┌

1.3.2.4. Framed simplicial complexes as framed regular cell complexes. As mentioned previously, geometric simplicial complexes may of course be considered as geometric regular cell complexes. Recall from [Construction 1.3.30](#) the combinatorial analog of that consideration, namely the fully faithful embedding $\mathbb{F} : \mathbf{SimpCplx} \hookrightarrow \mathbf{CellCplx}$, taking a simplicial complex K to its face poset $\mathbb{F}K$. We now describe the framed version of this embedding, from framed simplicial complexes into framed regular cell complexes.

TERMINOLOGY 1.3.61 (Barycentric subdivision of simplicial complexes). Given a simplicial complex K , its ‘barycentric subdivision’ is the simplicial complex $(N(\mathbb{F}K))^{\text{un}}$, obtained as the unordering of the nerve of the face poset of the simplicial complex K .¹⁵ There is no simplicial map from the subdivision to the original complex (or vice versa) whose geometric realization is a homeomorphism. Instead, we directly consider a homeomorphism $|N(\mathbb{F}K)^{\text{un}}| \cong |K|$ to be a ‘geometric barycentric subdivision’ when it takes every geometric simplex $|(x_0 \rightarrow \cdots \rightarrow x_k)^{\text{un}}|$, for simplices $x_i \in K$ each with face x_{i+1} , into the geometric simplex $|x_0|$. —

CONSTRUCTION 1.3.62 (Framed face posets). For an n -framed simplicial complex (K, \mathcal{F}) , define its ‘framed face poset’ to be the framed regular cell complex $(\mathbb{F}K, \mathbb{F}\mathcal{F})$, whose cellular poset $\mathbb{F}K$ is the face poset (from [Construction 1.3.30](#)), and whose framing $\mathbb{F}\mathcal{F}$ specified as follows.

Suppose that the framed simplicial complex is a single m -simplex K with an n -embedded framing \mathcal{F} . Consider any framed realization $|K| \hookrightarrow \mathbb{R}^n$, and pick any geometric barycentric subdivision $|N(\mathbb{F}K)^{\text{un}}| \cong |K|$. The framing $\mathbb{F}\mathcal{F}$ is the unique framing of the underlying simplicial complex of $\mathbb{F}K$, i.e. of $(N(\mathbb{F}K))^{\text{un}}$, such that the composite map $|N(\mathbb{F}K)^{\text{un}}| \cong |K| \hookrightarrow \mathbb{R}^n$ is a framed realization.

Then for a general simplicial complex K with n -framing \mathcal{F} , the framing $\mathbb{F}\mathcal{F}$ on the cellular poset $\mathbb{F}K$ is determined by the framing (give as above) on the cellular subposets $\mathbb{F}L \hookrightarrow \mathbb{F}K$ for each separate simplex $L \hookrightarrow K$. —

NOTATION 1.3.63 (Framed face poset functor). To a framed simplicial complex (K, \mathcal{F}) , we can associate the framed face poset $(\mathbb{F}K, \mathbb{F}\mathcal{F})$ as in the preceding construction; to a framed simplicial map $F : (K, \mathcal{F}) \rightarrow (L, \mathcal{G})$, we can associate the framed cellular map whose underlying cellular map of cellular posets is the face poset map $\mathbb{F}F : \mathbb{F}K \rightarrow \mathbb{F}L$. Together these provide a fully faithful ‘framed face poset functor’:

$$\mathbb{F} : \mathbf{FrSimpCplx}_n \hookrightarrow \mathbf{FrCellCplx}_n$$

By construction, this functor descends, along the forgetful functors to simplicial complexes and regular cell complexes, to the ordinary face poset functor. —

¹⁵This procedure should be contrasted with the barycentric subdivision of combinatorial regular cell complexes in [Terminology 1.3.31](#), which is instead obtained as the face poset of the unordering of the nerve.

EXAMPLE 1.3.64 (Framed regular cell complexes of framed simplicial complexes). In Figure 1.61, we depict two framed simplicial complexes and their associated framed cell complexes (obtained as framed face posets). On the left we show the two framed simplicial complexes along with their framed realizations. On the right we show the two associated framed cell complexes (via their ordered framed simplicial complexes) along with their schematic framed cellular realizations. Notice that the cells of the framed cell complex correspond exactly to the simplices of the framed simplicial complex; in the realization, the cells are depicted with curved boundary to remind us that they are being considered as cells not simplices (so a priori need not be realized by a map linear on every boundary cell). \square

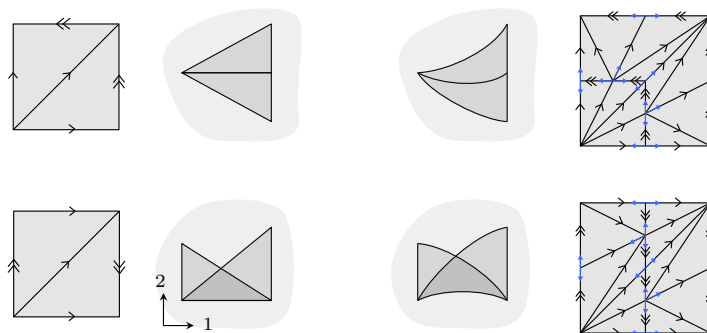

FIGURE 1.61. Framed simplicial complexes and their associated framed cell complexes.

1.3.2.5. Tractability of framed regular cells. The zoo of framed regular cells illustrated in Section 1.3.2.2, and especially the more extensive menagerie in Chapter C, raises the question of whether framed regular cells are a tractible class of basic shapes upon which to develop a computable combinatorial theory. We remark, with reference to later results, that framed cells are indeed tractible at least in the algorithmic sense that they are decidable enumerable.

TERMINOLOGY 1.3.65 (Decidably enumerable). We will say a subset $S \subset T$ is ‘decidably enumerable’ if the set S is computably enumerable, and the problem of whether an element of the ambient set T is in the subset S is decidable. \square

REMARK 1.3.66 (Decidable enumerability from monotonic enumerability). A computable enumeration of a set S (i.e. a finite algorithm listing all elements of the set) is less useful, theoretically and practically, than it may sound. Indeed, given some element of a larger set $T \supset S$, one cannot determine whether it is in the subset by, for instance, comparing it one by one to elements of the enumeration of the subset (since that procedure never halts

on elements of the complement $T \setminus S$); this issue remains even if the superset is itself computably enumerable and even if the comparison is finite algorithmic.

However, if one has enumerations of both the subset and the superset that are monotonic, in the sense that they are ordered with respect to some suitably related complexity measures, then the subset is certainly decidable: given an element of the ambient set, one only need compare to elements in the enumeration of the subset up to some a priori bounded complexity. In practice, we emphasize decidable enumerability, rather than enumerability and decidability independently, because we will infer decidability properties from sufficiently controlled enumerations. \square

CONVENTION 1.3.67 (Computability claims refer to finite objects). Whenever we will refer to an algorithmic property of a combinatorially defined class of objects, for instance enumerability, decidability, recognizability, or computability, we will be, completely without indication or comment, restricting attention to the subclass of finite such objects. \square

REMARK 1.3.68 (Combinatorial regular cells are enumerable but not decidable so). Recall a combinatorial regular cell is a cellular poset with an initial object, and a cellular poset is a locally finite poset whose upper links are triangulated standard spheres. Finite cellular posets can be enumerated;¹⁶ however, one manifestation of the computable intractibility of unframed regular cells is they are unrecognizable. Indeed, spheres are famously unrecognizable among simplicial complexes [VKF74, CL06], and in fact they are also among upper links in posets. Thus cellular posets are not recognizable among posets, and so in particular not decidable enumerable. (Hence, concretely, neither cellular posets nor specifically regular cells are monotonically enumerable: it is impossible to provide an algorithm for producing a list of all regular cells with, for instance, a given number of boundary cells.) \square

REMARK 1.3.69 (Framed regular cells are decidable enumerable). By marked contrast with the unframed situation, framed regular cells can be decidable enumerated (within the class of framed posets, that is posets with a framing of their underlying simplicial complex). Of course, enumerability is plausible, based on the enumerability of regular cells: one need only enumerate framings on the underlying simplicial complex and algorithmically check the cell-wise collapsibility condition. The novelty is the existence of a recognition algorithm for framed regular cells: the presence of a combinatorial framing (however singular) provides enough structure to computably decide whether the upper links are spheres. Thus altogether framed regular cells are decidable enumerable; that fact will eventually follow from the constructive combinatorial classification of framed regular cells (established in Theorem 3.1.1) by trusses (as developed in Chapter 2). \square

¹⁶Finite posets can be enumerated, and triangulations of the standard spheres can be enumerated; a suitable diagonal algorithm provides an enumeration of posets satisfying the link condition.

Beyond the intrinsic computability features, we might wonder about the complexity of our class of basic shapes. For instance, the class of convex polytopes is itself also decidably enumerable, but the enumeration is wildly inefficient, for instance doubly exponential by testing abstract complexes for convex geometric realizations using the Tarski–Seidenberg theorem [Grü03, §5.5].

REMARK 1.3.70 (Framed regular cells need not be convex). Note that framed regular cells typically do not have cellular realizations as convex polytopes (and so neither their enumerability nor recognizability follows from that classical case). For instance, in Figure 1.53, only the last of the six framed regular 3-cells is realized by a convex polytope. Even more starkly, in Figure 1.54, the first framed regular 3-cell is not even realized by a convex body, much less a convex polytope. —

REMARK 1.3.71 (Framed regular cells are efficiently enumerable). The aforementioned constructive classification of framed regular cells will have an inductive character, and thereby permit an enumeration that is not just decidable but practical and efficient, for instance polynomial in the complexity of the cell. —

Finally, recall from Remark 1.3.33 that another fundamental source of unmanagability for unframed regular cells is that cellular posets need not be PL cellular posets, i.e. their upper links, though topological spheres, need not be piecewise linear spheres. Again, the addition of a framing circumvents these impediments.

REMARK 1.3.72 (Framed cells are piecewise linear). If a combinatorial regular cell admits a framing, then it is necessarily a PL cellular poset; in particular its boundary is piecewise linearly homeomorphic to the standard piecewise linear sphere. (Thus the notion of framed regular cell is just identical to the notion of framed regular PL cell.) This fact will be recorded and proven in Corollary 3.3.31. —

We note that convex polytopes also have the virtue of being automatically PL cells (see [Bjö84, Prop. 4.5ff, Thm. 6.1]). In these various senses (enumerability, recognizability, piecewise linearity), both convex polytopes and framed regular cells provide sane computable classes of cells for combinatorial topology.

We have concentrated so far on the tractability of framed regular cells; we may consider more generally framed regular cell complexes. Indeed, we have already, albeit obliquely, encountered an especially well-behaved class of framed regular cell complexes, whose algorithmic tractability we will investigate much later. We introduce this class of ‘ n -directed acyclic graphs’ and preview its properties as follows.

TERMINOLOGY 1.3.73 (*n*-Directed graphs). We will use the term ***n*-directed graph** as a synonym for ‘*n*-framed regular cell complex’. This term is meant to evoke that such an object is a higher-dimensional graph, i.e. a complex, together with a suitably compatible choice of *n* directions on its cells. The terminology also implicitly claims that this notion is a robust higher-dimensional generalization of the classical notion of (1-)directed graphs.¹⁷ When directedness is sufficiently clear from context, we may abbreviate ‘*n*-directed graph’ to ‘*n*-graph’, but this latter term should not be confused with the notion of unframed regular *n*-dimensional cell complex. —

DEFINITION 1.3.74 (*n*-Directed acyclic graphs). An ***n*-directed acyclic graph** is an *n*-directed graph that admits a framed realization to *n*-dimensional euclidean space. —

Unpacking this definition via [Terminology 1.3.73](#) and [Terminology 1.3.37](#), with [Definition 1.2.14](#) and [Definition 1.1.44](#) yields: an *n*-directed acyclic graph is an *n*-framed regular cell complex (X, \mathcal{F}) that admits a map $|X| \rightarrow \mathbb{R}^n$ from the geometric realization to euclidean space, which is linear on each simplex, respects the frame vectors (by sending them into the corresponding positive standard components), and is an embedding on each cell.

TERMINOLOGY 1.3.75 (*n*-DAGs). We will further abbreviate ‘*n*-directed acyclic graph’ to ‘*n*-DAG’. Of course, the term ‘*n*-directed acyclic graph’ implicitly and boldly claims that this notion is itself a robust higher-dimensional generalization of the classical notion of (1-)directed acyclic graph.¹⁸ We will leave defending that claim to another time. —

EXAMPLE 1.3.76 (1-Directed and 1-directed acyclic graphs). In [Figure 1.62](#), we depict on the lower left a 1-directed graph and on the upper left a 1-directed acyclic graph. Their non-acyclicity and acyclicity, respectively, are witnessed by the non-existence and existence of a framed realization to \mathbb{R}^1 . For better visualizability, we may consider both 1-complexes as 2-directed graphs and consider whether they admit a framed realization to \mathbb{R}^2 . The \mathbb{R}^1 -realization of the upper graph lifts along the projection to an \mathbb{R}^2 -realization as shown. The lower graph, necessarily, also fails to have a 2-dimensional realization. —

REMARK 1.3.77 (*n*-DAGs have coarsest cell structures). A space that admits a regular cell complex structure has in no sense a minimal or coarsest such cell structure; equivalently, given a regular cell complex, there is no

¹⁷For convenience, we take the word ‘graph’ to allow multiple edges between the same pair of vertices, and to exclude loops; that choice avoids the proliferation of the modifiers ‘simple’ and ‘multi’. In the higher-dimensional case, of course, the notion of ‘*n*-directed graph’ similarly allows multiple cells with the same boundary, and excludes non-regular complexes.

¹⁸As in the previous footnote we have suppressed the modifier ‘multi’, but do allow parallel edges or more generally cells. If for some reason one really wanted to exclude such, one can simply add the condition that cells are determined by their boundaries.

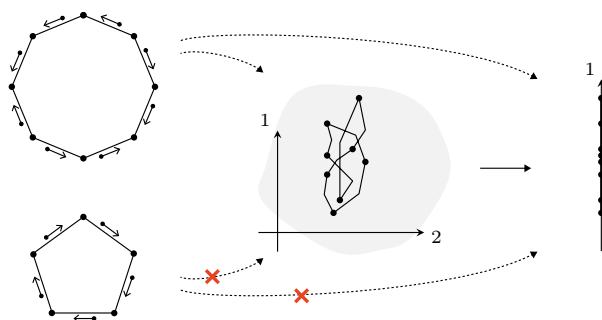

FIGURE 1.62. Acyclicity of 1-directed graphs via framed realization.

coarsest complex in that homeomorphism class. Adding directedness is not enough to improve the situation: given an n -directed graph, there is no coarsest n -directed graph in its framed homeomorphism class. Remarkably though, adding both directedness and acyclicity affects a qualitative change: every n -directed acyclic graph is framed homeomorphic to a unique coarsest such graph. We will revisit and establish this result toward the end of Section 5.3, leveraging finally the techniques developed in Chapter 3 and Chapter 4. \square

REMARK 1.3.78 (Framed homeomorphism of n -DAGs is decidable). As a consequence of the existence of coarsest cell structures for n -DAGs, and (as we will eventually find) the computable combinatorializability of those cell structures, we show it is algorithmically decidable whether two n -DAGs are framed homeomorphic. That result will come as the final proof of the main text, in Section 5.3. \square

CHAPTER 2

Constructible framed combinatorics: trusses

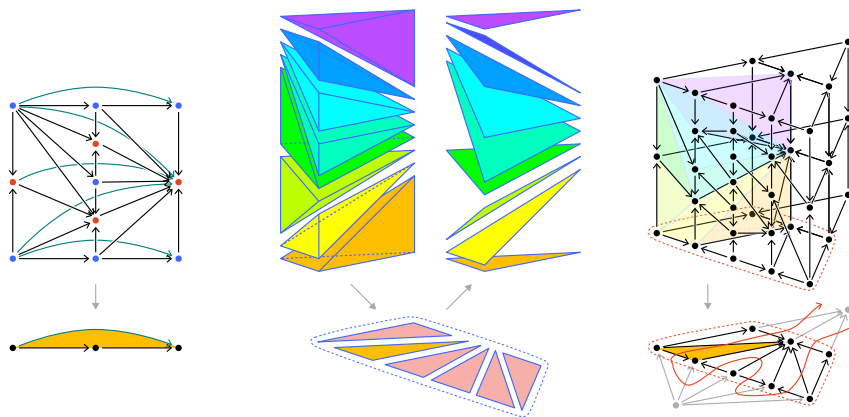

In this chapter, we develop the theory of trusses.¹⁹ Trusses are iterated constructible combinatorial bundles of framed fence posets. In [Chapter 3](#), we will prove that trusses yield a tractable, computable combinatorial classification of the framed regular cell complexes introduced in [Chapter 1](#). Furthermore, the stratified geometric realizations of trusses are iterated constructible bundles of framed stratified intervals, called meshes, and conversely the stratified fundamental posets of meshes are trusses. The theory of meshes will be developed in [Chapter 4](#), and trusses will provide, via an equivalence with meshes, a concrete combinatorial model of all possible local structures of constructible framed stratified topological spaces.

We begin this chapter, in [Section 2.1](#), by introducing 1-trusses, 1-truss bordisms and their composition, and 1-truss bundles. We then, in [Section 2.2](#), define a scaffold order on section and spacer simplices, and thus establish the method of truss induction for reasoning about simplices in the total posets of 1-truss bundles. Finally, in [Section 2.3](#), we define n -trusses as iterated 1-truss bundles, describe the combinatorial category of n -truss blocks, and present block sets as presheaves on truss blocks.

¹⁹The substantial foundational components of the theory of trusses were first formulated in [\[Dor18\]](#) under the name ‘singular cubes’.

2.1. 1-Trusses, bordisms, and bundles

For a typical stratified space, the fundamental poset of its strata and their incidence relations is a coarse representation of the space, at best. But when the strata are contractible and arranged in a sufficiently nice way, the fundamental poset can be, in fact, a faithful encoding. The simplest such case is that of stratified 1-manifolds: a stratified 1-manifold (say with at least three strata to avoid degenerate cases) is actually homeomorphic to the geometric realization of its fundamental poset. The fundamental posets so arising are fences, that is, roughly speaking, linear or circular posets with no composable arrows. In fact, we care in the first instance about framed stratified 1-manifolds, and will restrict attention to contractible such, i.e. intervals, for simplicity; a framing of a stratified interval provides its fundamental poset fence with a total ‘frame’ order. A fence with a framing is the essence of our combinatorial notion of a *1-truss*. An example 1-truss is illustrated on the left in Figure 2.1, where the framing direction is indicated by a small purple arrow and the blue and red dots indicate strata with 1- and 0-dimensional realizations, respectively.

The entertainments and intricacies of framed stratified intervals, and their combinatorial encoding by 1-trusses, begin to emerge when considered in stratified families. The simplest such case is of a stratified bundle of framed stratified intervals over the standard stratified 1-simplex. In such a family there is a generic fiber (over the open bulk of the 1-simplex), and a special fiber (over the closed endpoint of the 1-simplex), and some kind of transformation from the generic to special fiber. A sufficiently nice such stratified bundle of framed stratified intervals is, like the intervals themselves, faithfully encoded by its fundamental poset bundle over the standard stratified combinatorial 1-simplex $0 \rightarrow 1$. A triple of a generic fiber 1-truss and a special fiber 1-truss and a suitable transformation between them, will be called a *1-truss bordism*; here ‘suitable’ will mean satisfying a collection of combinatorial conditions (namely ‘bimonotone bifunctional functorial relation’) ensuring, eventually, that the bordism arises as the fundamental poset of a corresponding stratified bundle. An example 1-truss bordism is illustrated in the middle of Figure 2.1, where the generic fiber 1-truss is depicted on the left, the special fiber 1-truss is depicted on the right, and the transformation relation between them is depicted by the intermediate arrows.

Two bundles over unstratified 1-simplices may be composed by concatenation to form another bundle over a 1-simplex. However, the concatenation of two stratified intervals is not another stratified interval; it is therefore not immediately evident how one should or can go about composing stratified bundles over 1-simplices. By contrast, a striking, transparent property of the combinatorial encoding here is that *1-truss bordisms compose* simply as their underlying relations. An example 1-truss bordism composition is illustrated on the right in Figure 2.1, where the two composable 1-truss bordisms are depicted in gray, and their composite bordism is depicted in black. As is

discernible in the illustration, this situation of two composable bordisms may equivalently be considered as a *1-truss bundle* over the standard stratified combinatorial 2-simplex $0 \rightarrow 1 \rightarrow 2$. Of course, as the dimension of the base poset grows, it becomes increasingly difficult to depict or decipher the whole poset of a 1-truss bundle over the base. Precisely because the composite bordisms are combinatorially determined by their factors, it will always suffice to provide the 1-truss bordisms covering a collection of generating morphisms of the base poset; for instance, Figure 2.2 depicts (everything we need to encode) the total poset of a 4-dimensional 1-truss bundle over the 3-simplex.

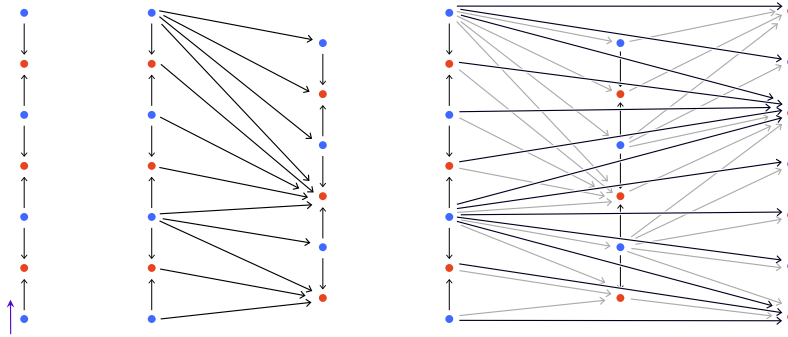

FIGURE 2.1. A 1-truss, a 1-truss bordism, and a 1-truss bordism composition.

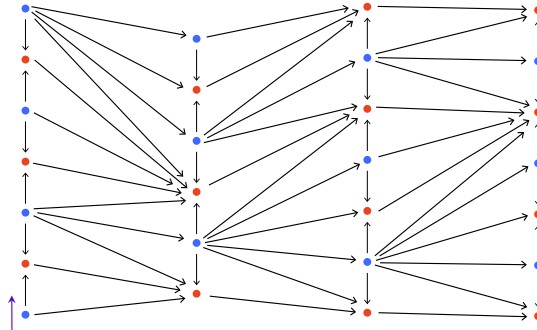

FIGURE 2.2. The total poset of a 1-truss bundle.

OUTLINE. In Section 2.1.1, we introduce 1-trusses as framed fences and maps of 1-trusses as those preserving both the framing and the fence order. In Section 2.1.2, we define 1-truss bordisms as functorial relations that are singular functional, regular cofunctional, and frame-order bimonotone, describe and illustrate assorted local behaviors of 1-truss bordisms, and observe that 1-truss bordisms compose. Finally, in Section 2.1.3, we describe 1-truss bundles as collections of 1-truss bordisms, and show that a category of 1-trusses and their bordisms is a classifying category for 1-truss bundles.

2.1.1. 1-Trusses.

SYNOPSIS. We introduce 1-trusses as framed fences, differentiate trivial, linear, and circular 1-trusses, reformulate the notion of linear 1-trusses in terms of a set with two interacting order relations, and distinguish singular and regular elements. We then introduce maps of 1-trusses as those preserving both orders, delineate the notions of singular, regular, and balanced maps, and classify the balanced isomorphism classes of 1-trusses according to the singularity and regularity of their endpoints. Finally we observe that there is an involutive dualization functor swapping singular and regular elements and interchanging open and closed 1-trusses.

2.1.1.1. 1-Trusses as framed fences. Recall the classical combinatorial notion of fences [Sta12]; 1-trusses will be finite fences with the additional structure of a suitable choice of dimension for objects and a consistent choice of framing for morphisms.

DEFINITION 2.1.1 (Fence). A **fence** is a connected category with countably many objects and morphisms, such that there are no composable (non-identity) morphisms, and such that there are at most two (non-identity) morphisms with source or target at any given object. \square

TERMINOLOGY 2.1.2 (Types of fences). Fences fall neatly into three types based on the topology of their geometric realization. Recall that the geometric realization of a category is the topological space associated to the simplicial set obtained by taking the nerve of the category. Notice that the geometric realization of any fence is either a connected 0-manifold or a connected 1-manifold.

- > When the geometric realization is a point, we say the fence is ‘trivial’.
- > When the geometric realization is an interval, we say the fence is ‘linear’.
- > When the geometric realization is a circle, we say the fence is ‘circular’.

We call a fence ‘finite’ if it has finitely many objects and finitely many morphisms. \square

EXAMPLE 2.1.3 (Fences). In Figure 2.3, we illustrate fences of different types. Each fence is depicted by its geometric realization, and the direction of morphisms in the fence is indicated by directing the edges of the geometric realization. \square

OBSERVATION 2.1.4 (Dimension functor). Every non-trivial fence T has a unique functor $T \rightarrow [1]^{\text{op}}$ whose preimages are discrete categories; this functor ‘folds the fence onto a single fence post’. We refer to such a functor as a ‘dimension’ functor, because the value of the functor on an object will be the dimension of a corresponding stratum in an associated stratified interval. Note that for a trivial fence, there are two distinct discrete-preimage functors $T \rightarrow [1]^{\text{op}}$, and so an ambiguity regarding the dimension of the object. \square

The notion of 1-truss strengthens the notion of fence in two ways: firstly, a 1-truss includes the data of a ‘progressive framing’ of the edges of its

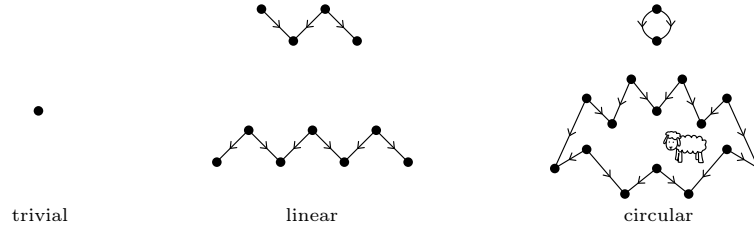

FIGURE 2.3. Fences of different types.

geometric realization; secondly, a 1-truss comes equipped with a specified dimension functor, resolving the dimension ambiguity for trivial fences.

TERMINOLOGY 2.1.5 (Progressive framing of a fence). A ‘progressive framing’ of a fence is a choice of direction of each edge of the geometric realization of the fence such that every vertex has at most one edge directed towards it and at most one edge directed away from it. └─

DEFINITION 2.1.6 (General 1-trusses). A **1-truss** (T, \dim, \mathcal{F}) is a finite fence T , together with a dimension functor $\dim : T \rightarrow [1]^{\text{op}}$ and a progressive framing \mathcal{F} . └─

TERMINOLOGY 2.1.7 (Types of general 1-trusses). A 1-truss is ‘trivial’ whenever its underlying fence is. A 1-truss is ‘linear’ whenever its underlying fence is either linear or trivial; in the latter case we refer to it as a ‘trivial linear’ 1-truss. (This terminology is convenient because the two trivial linear 1-trusses will correspond to the trivially stratified linear interval and the degenerate interval.) Similarly, a 1-truss is ‘circular’ whenever its underlying fence is either circular or trivial; in the latter case we refer to it as a ‘trivial circular’ 1-truss.²⁰ (Again this is convenient because, in the context of circular trusses, the two trivial circular 1-trusses will correspond to the trivially stratified circle and the degenerate circle.) Note that this means that trivial 1-trusses are both linear and circular. └─

EXAMPLE 2.1.8 (General 1-trusses). In Figure 2.4, we illustrate 1-trusses of the different types. In each case we depict the underlying fence; we indicate the dimension map by coloring preimages of 0 in red, and preimages of 1 in blue, and record the progressive framing by purple frame vectors adjacent to each edge. └─

Henceforth we will focus exclusively on the case of linear trusses. Much of the theory developed here, including the higher-dimensional notion of n -trusses, does generalize to the case of general (particularly circular) 1-trusses, but our main interest and applications will be in the linear case. Simplicity and brevity of exposition thus dictate the following convention.

²⁰Circular truss \rightsquigarrow **circus**.

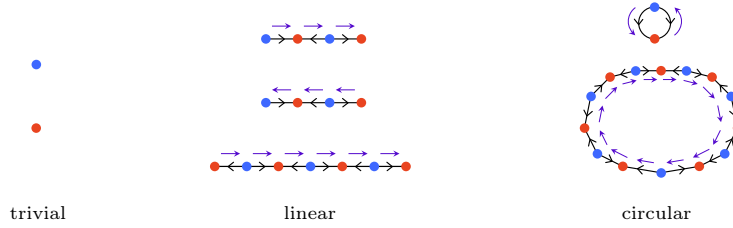

FIGURE 2.4. 1-Trusses of different types.

CONVENTION 2.1.9 (Linear 1-trusses by default). We will use the term ‘1-truss’ to mean ‘linear 1-truss’ unless otherwise noted. —

We may reformulate the definition of (linear) 1-trusses, without reference to fences, in terms of a set with two interacting order relations. First, note that any linear or trivial fence is a poset.²¹ We usually denote the poset order of linear (or trivial) fences by (T, \trianglelefteq) , though in illustrations we exclusively use the arrow notation (T, \rightarrow) inspired by the categorical, rather than partial order, interpretation. (The order notation \trianglelefteq will be convenient for expressing strictly less or strictly greater relations with the symbols \triangleleft and \triangleright .) Second, a progressive framing \mathcal{F} of a linear fence T may be equivalently encoded by a total order on the objects; we usually denote this order by \preceq . Together these orders provide the basis of our canonical definition, as follows.

DEFINITION 2.1.10 (1-Trusses). A (linear) **1-truss** $(T, \trianglelefteq, \dim, \preceq)$ is a finite nonempty set T together with the following structures:

- (1) a partial order \trianglelefteq , called the ‘face order’ of T ;
- (2) a poset map $\dim : (T, \trianglelefteq) \rightarrow [1]^{\text{op}}$, called the ‘dimension map’ of T ;
- (3) a total order (T, \preceq) , called the ‘frame order’ of T , for which either a succeeds b or b succeeds a if and only if either $a \triangleleft b$ or $a \triangleright b$. —

NOTATION 2.1.11 (1-Trusses). We will usually keep the face orders, dimension maps, and frame orders implicit, abbreviating the 1-truss $(T, \trianglelefteq, \dim, \preceq)$ simply by T . —

The terminology ‘face order’ for the partial order \trianglelefteq reflects the relationship between 1-trusses and stratified intervals: elements a of a 1-truss will correspond to strata of dimension $\dim(a)$ in a corresponding stratified interval, and the existence of an arrow $a \triangleleft b$ of the 1-truss will correspond to the stratum b being a face of the stratum a . This motivational relationship of 1-trusses and stratified intervals is illustrated in the following example.²²

²¹Every preorder, in particular every poset, (X, \leq) can be considered a category with object set X and a single morphism $x \rightarrow y$ whenever $x \leq y$. Every map of preorders can be considered as a functor of the corresponding categories.

²²Note that the correspondence of 1-trusses and stratified intervals is fundamentally different from the earlier depiction in [Example 2.1.8](#) of fences via their geometric realization as regular cell complexes.

EXAMPLE 2.1.12 (1-trusses and corresponding stratified intervals). In Figure 2.5, we depict two 1-trusses and two stratified intervals. For the 1-trusses, we color blue the elements whose dimension map value is 1 and we color red the elements whose dimension map value is 0; we depict the face order by black arrows; and we indicate the overall direction of increasing frame order by a single purple vector. For the stratified intervals, the 0-strata are indicated by small black dots, and the 1-strata are indicated by black open intervals. Each 1-truss and its adjacent stratified interval correspond in the sense that the face order of the 1-truss is the fundamental poset of the stratified interval. Note that each object of the truss corresponds to a stratum of the same dimension. (The frame order of the truss corresponds to a framing of the stratified interval provided by an implicit embedding in the real line.) —



FIGURE 2.5. 1-Trusses and their corresponding stratified intervals.

Inspired by much later applications to singularity theory, we adopt the following terminology.

TERMINOLOGY 2.1.13 (Singular and regular elements). An element $a \in T$ of a 1-truss T is called ‘singular’ if $\dim(a) = 0$, and ‘regular’ if $\dim(a) = 1$. We denote the subset of singular elements of T by $\text{sing}(T)$, and the subset of regular elements of T by $\text{reg}(T)$. —

REMARK 2.1.14 (Orders on singular and regular elements). Note that, considered with the face order, the singular set $(\text{sing}(T), \trianglelefteq)$ and regular set $(\text{reg}(T), \trianglelefteq)$ are discrete orders, while, considered with the frame order, the singular set $(\text{sing}(T), \preceq)$ and regular set $(\text{reg}(T), \preceq)$ are total orders. —

Since 1-trusses may be considered as fence categories or as sets with partial face orders, going forward we will refer interchangeably to either ‘elements’ or ‘objects’ of 1-trusses.

2.1.1.2. Maps of 1-trusses. We next define maps of 1-trusses and distinguish certain specific classes of maps based on their behavior on singular and regular objects. As 1-trusses have two partial orders, the face and frame orders, maps thereof are conveniently and succinctly expressed in terms of diposets as follows.

DEFINITION 2.1.15 (Diposets and their maps). A **diposet** $(X, \trianglelefteq, \preceq)$ is a set X with two partial orders \trianglelefteq and \preceq . A **diposet map** $F : (X, \trianglelefteq, \preceq) \rightarrow$

$(Y, \trianglelefteq, \preceq)$ is a map of sets $F : X \rightarrow Y$ that independently respects both orders, i.e. induces poset maps $F : (X, \trianglelefteq) \rightarrow (Y, \trianglelefteq)$ and $F : (X, \preceq) \rightarrow (Y, \preceq)$. ---

DEFINITION 2.1.16 (1-Truss maps). A **map of 1-trusses** $T \rightarrow S$ is a diposet map $(T, \trianglelefteq, \preceq) \rightarrow (S, \trianglelefteq, \preceq)$. ---

Note that the definition of a 1-truss map does not impose any conditions on how the map interacts with the dimension maps of the trusses. Indeed, there are several distinct such potential interactions, depending on the map's behavior on singular and regular objects.

DEFINITION 2.1.17 (Singular, regular, and balanced maps). Let $F : T \rightarrow S$ be a map of 1-trusses.

- > The map F is **singular** if it sends singular objects of T to singular objects of S . In other words, for all $a \in T$, $\dim(a) \geq \dim(Fa)$.
- > The map F is **regular** if it sends regular objects of T to regular objects of S . In other words, for all $a \in T$, $\dim(a) \leq \dim(Fa)$.
- > The map F is **balanced** if it is both singular and regular. In other words, for all $a \in T$, $\dim(a) = \dim(Fa)$. ---

EXAMPLE 2.1.18 (Maps of 1-trusses). In Figure 2.6, we depict a singular, a regular, and a balanced map of 1-trusses, and one that is neither singular nor regular. ---

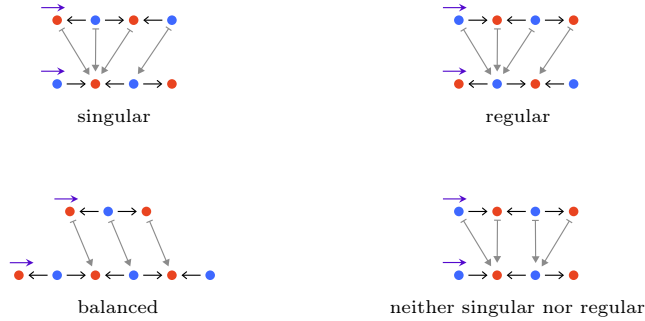

FIGURE 2.6. Types of maps of 1-trusses.

NOTATION 2.1.19 (Category of 1-trusses). The category of 1-trusses and their maps is denoted Tr_1 . The wide subcategory containing only singular, respectively regular, respectively balanced maps will be denoted Tr_1^s , respectively Tr_1^r , respectively Tr_1^{fs} . ---

Since a map of 1-trusses that is neither singular nor regular does not abide any condition on the dimension map, a priori in the category of 1-trusses, the trivial truss of dimension 0 (i.e. with one element $a \in T$ having $\dim(a) = 0$) is isomorphic to the trivial truss of dimension 1 (i.e. with one element $a \in T$ having $\dim(a) = 1$); however as we typically want to distinguish these 1-trusses, we adopt the following convention.

CONVENTION 2.1.20 (Balanced isomorphism by default). The term ‘isomorphism of 1-trusses’ will refer, unless otherwise noted, to isomorphism in the category Tr_1^{fs} , that is, to balanced bijective 1-truss maps. (Note that balanced isomorphisms preserve all the structural data of 1-trusses, namely the face order, the frame order, and the dimension map.) \square

REMARK 2.1.21 (Balanced isomorphisms of 1-trusses are unique). If two 1-trusses are balanced isomorphic, there is a *unique* balanced isomorphism between them. There is therefore never any need to distinguish between distinct but balanced isomorphic 1-trusses. Also, in particular, there are no nontrivial balanced automorphisms of 1-trusses. (In fact, a not-necessarily-balanced isomorphism between 1-trusses is also unique, but by the previous convention we care about and concentrate on balanced isomorphism.) \square

As intervals are crucially distinguished by whether they are open, closed, half-open-half-closed, or degenerate, so too are stratified intervals and, correspondingly, 1-trusses. For 1-trusses, these distinctions are controlled by whether the endpoints are singular or regular.

TERMINOLOGY 2.1.22 (Endpoints of 1-trusses). For a 1-truss $(T, \trianglelefteq, \dim, \preceq)$, we refer to the minimal element of the frame order (T, \preceq) as the ‘lower endpoint’ and denote it by end_-T ; similarly we refer to the maximal element as the ‘upper endpoint’ and denote it by end_+T . \square

TERMINOLOGY 2.1.23 (Endpoint types of 1-trusses). There are six ‘endpoint types’ of balanced isomorphism classes of 1-trusses, distinguished and referred to as follows. Let T be a 1-truss.

- (1) If T has a single element and that element is regular, then T is the ‘trivial open’ 1-truss and is denoted by $\overset{\circ}{\mathbb{T}}_0$.
- (2) If T has a single element and that element is singular, then T is the ‘trivial closed’ 1-truss and is denoted by $\overline{\mathbb{T}}_0$.

For the remaining cases, assume the 1-truss T has more than one element.

- (3) If both endpoints $\text{end}_{\pm}T$ are regular, then T is ‘open’. When T has $2k + 1$ elements, it is denoted by $\overset{\circ}{\mathbb{T}}_k$.
- (4) If both endpoints $\text{end}_{\pm}T$ are singular, then T is ‘closed’. When T has $2k + 1$ elements, it is denoted by $\overline{\mathbb{T}}_k$.
- (5) If end_-T is regular and end_+T singular, then T is ‘left-open right-closed’. When T has $2k$ elements, it is denoted by $\overset{\circ}{\overline{\mathbb{T}}}_k$.
- (6) If end_-T is singular and end_+T regular, then T is ‘left-closed right-open’. When T has $2k$ elements, it is denoted by $\overline{\overset{\circ}{\mathbb{T}}}_k$.

The last two cases are both referred to as ‘half-open’ 1-trusses. \square

EXAMPLE 2.1.24 (Types of 1-trusses). In Figure 2.7 we depict an example of each of the six types of 1-trusses, distinguished by their endpoints. \square

We will mainly be concerned with the cases of entirely closed trusses and of entirely open trusses, as opposed to the half-open cases, and so we introduce notation for the following subcategories.

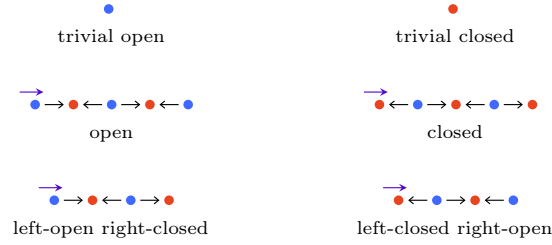

FIGURE 2.7. Endpoint types of 1-trusses.

NOTATION 2.1.25 (Open and closed 1-trusses). The subcategory of Tr_1 whose objects are open trusses (including the trivial open truss) and whose morphisms are regular maps, will be denoted by $\overset{\circ}{\text{Tr}}_1$. The subcategory of Tr_1 whose objects are closed trusses (including the trivial closed truss) and whose morphisms are singular maps, will be denoted by $\bar{\text{Tr}}_1$. ---

2.1.1.3. Dualization of 1-trusses. There is a natural *dualization* operation taking closed trusses to open trusses and vice versa.

CONSTRUCTION 2.1.26 (Dualization of 1-trusses). There is a covariant involutive functor, called the ‘dualization functor’, denoted

$$\dagger : \text{Tr}_1 \cong \text{Tr}_1$$

and defined as follows. Given a 1-truss $T = (T, \triangleleft, \dim, \preceq)$, its dual is the 1-truss $T^\dagger = (T, \triangleleft^{\text{op}}, \dim^{\text{op}}, \preceq)$. That is, the face order of T^\dagger is opposite to the face order of T ; the dimension map of T^\dagger is the opposite of the dimension map of T (post-composed with the identification $[1] \cong [1]^{\text{op}}$); and the frame order of T^\dagger is the same as the frame order of T . The dual $F^\dagger : T^\dagger \rightarrow S^\dagger$ of a 1-truss map $F : T \rightarrow S$ is the map whose underlying map of sets is equal to the underlying map of sets $T \rightarrow S$ of the map F . ---

EXAMPLE 2.1.27 (Dualization of 1-trusses and 1-truss maps). In Figure 2.7, the 1-trusses in the left column are dual, respectively, to the 1-trusses in the right column. In Figure 2.6, the singular map dualizes to the regular map. ---

OBSERVATION 2.1.28 (Singular and regular are dual). Given a 1-truss T , an element $a \in T$ is singular, respectively regular, if and only if the corresponding element $a \in T^\dagger$ is regular, respectively singular. Similarly, a map of 1-trusses $F : T \rightarrow S$ is singular, respectively regular, if and only if the dual $F^\dagger : T^\dagger \rightarrow S^\dagger$ is regular, respectively singular. ---

OBSERVATION 2.1.29 (Closed and open are dual). Since singular and regular elements are exchanged by dualization, the endpoint types are similarly exchanged. In particular open 1-trusses dualize to closed 1-trusses and vice versa; the dualization functor restricts to an isomorphism $\dagger : \overset{\circ}{\text{Tr}}_1 \cong \bar{\text{Tr}}_1$. ---

2.1.2. 1-Truss bordisms. As described and illustrated in the previous section, 1-trusses provide a combinatorial model of (framed) stratified intervals. Next we introduce 1-truss bordisms, which provide a combinatorial model of certain families of stratified intervals. More specifically, 1-truss bordisms will model suitably constructible stratified bundles, of framed stratified intervals, over the standard stratified 1-simplex.²³ Two such bundles are illustrated in Figure 2.8. In the first bundle, the generic fiber is a stratified open interval with two point strata; those point strata collide into a single point stratum when entering the special fiber. In the second bundle, the generic fiber again has two point strata, but when entering the special fiber, a third point stratum spontaneously appears. In both cases, we also depict the fundamental poset of the total space of the stratified bundle, and the map of posets to the fundamental poset of the stratified interval; these ‘stratified bundles of 1-truss posets’ are the ‘1-truss bordisms’ corresponding to the geometric stratified bundles. The notion of 1-truss bordism encodes a unified combinatorial description of the possible changes between the 1-truss fibers in such stratified fundamental poset bundles.

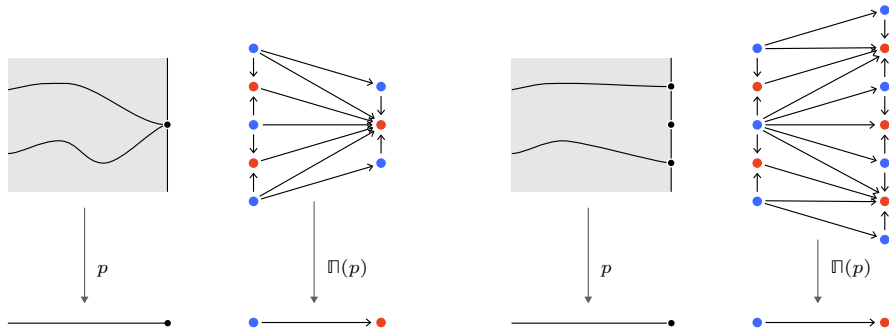

FIGURE 2.8. Stratified bundles of stratified intervals and their corresponding fundamental posets as 1-truss bordisms.

SYNOPSIS. We begin by giving the crucial definition of 1-truss bordisms as functorial relations that are functional on singular elements, cofunctional on regular elements, and bimonotone in the frame orders. We then illustrate various local phenomena that occur in 1-truss bordisms, along with an assortment of 1-truss relations that fail to be 1-truss bordisms. We observe that there is a composition operation of 1-truss bordisms, and therefore a category of 1-trusses and their bordisms. We describe a dualization operation of 1-truss bordisms, and the resulting contravariant involutive dualization functor on the category. We then show that subject to suitable boundary conditions, a 1-truss bordism is completely determined by either of its function

²³Recall stratified bundles generalize fiber bundles by allowing the fibers to change when passing between strata of the base; see Definition B.2.24. The condition of constructibility controls what sort of fiber changes are allowed; see Remark B.2.29.

on singular elements or its cofunction on regular elements. Finally, we explain the relationship between 1-truss maps and 1-truss bordisms, namely that singular 1-truss maps have associated mapping cylinder 1-truss bordisms and regular 1-truss maps have associated mapping cocylinder 1-truss bordisms.

2.1.2.1. 1-Truss bordisms as bimonotone bifunctional functorial relations. Inspired by the behavior of fundamental posets of stratified bundles of stratified intervals, we develop the combinatorial notion of 1-truss bordisms. In the stratified bundles illustrated above in Figure 2.8, from a given stratum of the generic fiber, there may be entrance paths (see Definition B.1.5) leading to multiple distinct strata of the special fiber. Thus in the corresponding fundamental posets, there may be an order relation between a single element of the generic fiber and multiple elements of the special fiber. The combinatorial change from generic to special fiber is therefore in no way a function of posets; rather, it is a specific sort of relation of posets.

Again in the stratified bundles of Figure 2.8, when there is an entrance path $r_0 \rightarrow s_0$ within the generic fiber and an entrance path $s_0 \rightarrow s_1$ from the generic fiber to the special fiber, then there is always a direct entrance path $r_0 \rightarrow s_1$ from the source generic stratum to the special stratum. Similarly, when there is an entrance path $r_0 \rightarrow r_1$ from the generic fiber to the special fiber and an entrance path $r_1 \rightarrow s_1$ within the special fiber, then there is a direct entrance path $r_0 \rightarrow s_1$ from the generic stratum to the target special stratum. In this sense, the relation between the fundamental poset of the generic fiber and the fundamental poset of the special fiber respects composition with the poset arrows of both source and target; such a relation is called ‘functorial’.

TERMINOLOGY 2.1.30 (Functorial relation). For preorders X and Y , a ‘functorial relation’ $R : X \rightarrow Y$ is a relation $R \subset X \times Y$ (between the object sets of the preorders) for which, if there is an arrow $r_0 \rightarrow s_0$ of X and a relation $R(s_0, s_1)$, then there is a relation $R(r_0, s_1)$, and for which, if there is a relation $R(r_0, r_1)$ and an arrow $r_1 \rightarrow s_1$ of Y , then there is a relation $R(r_0, s_1)$. —

Of course, not any functorial relation can arise from the entrance paths on stratified bundles of stratified intervals, because the arrangements of generic and special, singular and regular strata are quite constrained. Notice in particular that generic singular strata converge to special singular strata, and so, on fundamental posets, there is always a relation between any singular object of the source and some singular object of the target; in this sense the relation is ‘functional’ on singular objects. Furthermore, notice that any special regular stratum has a nearby generic regular stratum, and so, on fundamental posets, there is always a relation between some regular object of the source and any given regular object of the target; in this sense the relation is ‘cofunctional’ on regular objects.

TERMINOLOGY 2.1.31 (Functional and cofunctional relations). For sets (i.e. discrete preorders) X and Y , a function $f : X \rightarrow Y$ induces the associated relation $R_f := \{(x, f(x)) | x \in X\} \subset X \times Y$. A ‘functional relation’ is one that is associated to a function in this sense.

Similarly, a cofunction $f : X \leftarrow Y$ induces the associated relation $R^f := \{(f(y), y) | y \in Y\} \subset X \times Y$. A ‘cofunctional relation’ is one that is associated to a cofunction in this sense. \square

Finally, since a stratified bundle of stratified intervals is in particular a continuous bundle of intervals, the linear order of strata within the generic fiber is weakly preserved when entering into the special fiber, and the linear order of strata within the special fiber is weakly preserved when exiting into the generic fiber; in particular the relation on fundamental posets is weakly (frame) order preserving or ‘bimonotone’ in the following sense.

TERMINOLOGY 2.1.32 (Bimonotone relation). For total orders X and Y , a relation $R \subset X \times Y$ (between the object sets of the orders) is ‘bimonotone’ if, given relations $R(x, y)$ and $R(x', y')$, there is an arrow $x \rightarrow x'$ in X if and only if there is an arrow $y \rightarrow y'$ in Y . \square

A pair of non-identity arrows $x \rightarrow x'$ in X and $y \rightarrow y'$ in Y is called a ‘transposition’ of the relation if both $R(x, y')$ and $R(x', y)$. A relation is bimonotone exactly when it has no transpositions.

Altogether, we can finally define the fundamental notion of 1-truss bordisms. Recall from Remark 2.1.14 that the singular objects, and separately the regular objects, of a truss T form discrete subposets $(\mathbf{sing} T, \trianglelefteq)$ and $(\mathbf{reg} T, \trianglelefteq)$ of the face order (T, \trianglelefteq) .

DEFINITION 2.1.33 (1-truss bordisms). A **1-truss bordism** $R : T \rightarrow S$ between 1-trusses T and S is a nonempty functorial relation $R : (T, \trianglelefteq) \rightarrow (S, \trianglelefteq)$ of the face orders of T and S satisfying the following two conditions.

- (1) *Bifunctionality*: On singular elements, the restricted relation $R : (\mathbf{sing} T, \trianglelefteq) \rightarrow (\mathbf{sing} S, \trianglelefteq)$ is functional, and on regular elements, the restricted relation $R : (\mathbf{reg} T, \trianglelefteq) \rightarrow (\mathbf{reg} S, \trianglelefteq)$ is cofunctional.
- (2) *Bimonotonicity*: The relation $R \subset T \times S$ is bimonotone with respect to the frame orders (T, \preceq) and (S, \preceq) . \square

TERMINOLOGY 2.1.34 (Singular and regular functions of a truss bordism). The bifunctionality condition requires that for each singular element $a \in \mathbf{sing} T$ there is a unique singular element $\mathbf{sing}_R(a) \in \mathbf{sing} S$ such that $R(a, \mathbf{sing}_R(a))$, and for each regular element $d \in \mathbf{reg} S$ there is a unique regular element $\mathbf{reg}^R(d) \in \mathbf{reg} T$ such that $R(\mathbf{reg}^R(d), d)$. The resulting function $\mathbf{sing}_R : \mathbf{sing} T \rightarrow \mathbf{sing} S$ is called the ‘singular function’ of R . Similarly, the function $\mathbf{reg}^R : \mathbf{reg} S \rightarrow \mathbf{reg} T$ is called the ‘regular function’ of R . \square

EXAMPLE 2.1.35 (A 1-truss bordism). In Figure 2.9, we depict a 1-truss bordism $R : T \rightarrow S$. The domain 1-truss T is drawn on the left, the codomain 1-truss S is drawn on the right, and elements of the relation R are indicated

by rightward arrows between objects of T and S . That the relation R is bimonotone is visible from there being no crossings among its edges. That the relation R is bifunctional is witnessed by the left-to-right singular function $\text{sing}_R : \text{sing } T \rightarrow \text{sing } S$ highlighted in red, and the right-to-left regular function $\text{reg}^R : \text{reg } S \rightarrow \text{reg } T$ highlighted in blue. \square

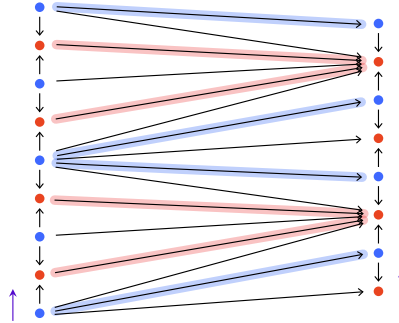

FIGURE 2.9. A 1-truss bordism.

EXAMPLE 2.1.36 (A bifunctional functorial relation that is not a truss bordism). In Figure 2.10, we depict a bifunctional functorial relation $R : T \leftrightarrow S$, between the same two 1-trusses as in the previous example, which though is not bimonotone and therefore not a truss bordism. \square

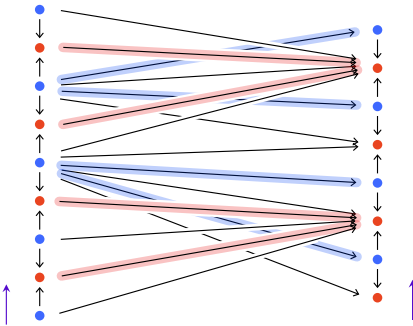

FIGURE 2.10. Not a 1-truss bordism.

REMARK 2.1.37 (Truss bordisms are really half-bordisms). Recall that an elementary manifold bordism [Sto68], that is one with a single Morse critical point, can be considered as a cospan of two mapping cylinders of maps from the source and target manifolds onto a common intermediate singular manifold. See the left side of Figure 1.33 for an illustration. What we have called a ‘truss bordism’ is really analogous to only half of a classical

geometric bordism, that is to the mapping cylinder of a single map from a manifold to an intermediate singular manifold. To obtain a truss structure more completely deserving of the name ‘bordism’, we would need to consider a cospan of truss bordisms. Such a cospan is illustrated in Figure 2.11. This structure indeed has the symmetric character typical of a geometric bordism, with the source and target both mapping onto an intermediate ‘singular’ slice. And indeed, these cospans will be the ubiquitous structure in the subsequent theory. Nevertheless, to have a concise and suggestive and familiar term for the core notion of half of such a cospan, and to avoid an interminable repetition of the prefix ‘half-’, we refer to what is defined above as truss bordisms simply as ‘truss bordisms’ and not as ‘truss half-bordisms’. \square

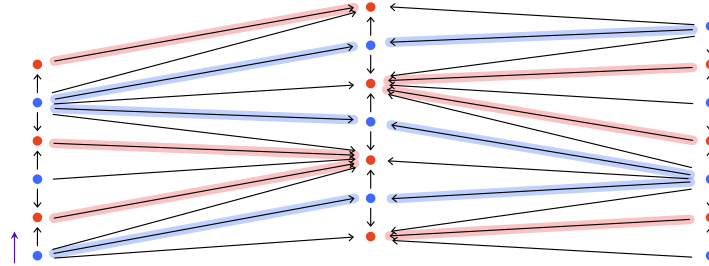

FIGURE 2.11. A 1-truss bordism cospan.

We may recast the above notions regarding 1-truss bordisms in more abstract categorical terms, as follows. (Less categorically-inclined readers may freely skip ahead to Section 2.1.2.2.) Recall that the category \mathbf{Bool} of boolean values has two objects ‘true’ \top (also written 1 or $*$) and ‘false’ \perp (also written 0 or \emptyset), with a single non-identity morphism from false to true. Moreover, this category is monoidal under logical conjunction (i.e. multiplication on $\{0, 1\}$, i.e. cartesian product on $\{\emptyset, *\}$). Considering \mathbf{Bool} as $\{\emptyset, *\}$ provides a fully faithful monoidal functor $\mathbf{Bool} \hookrightarrow \mathbf{Set}$, which we may use to think of \mathbf{Bool} -enriched categories as ordinary categories. Observe that \mathbf{Bool} -enriched categories are precisely preorders. These formalities are defensible because boolean-enriched profunctors concisely and precisely encode functorial relations and their composition, as follows.

DEFINITION 2.1.38 (Boolean profunctors). Given two preorders X and Y , a **boolean profunctor** $R : X \dashv\vdash Y$ is a functor $R : X^{\text{op}} \times Y \rightarrow \mathbf{Bool}$. \square

NOTATION 2.1.39 (Category of boolean profunctors). Preorders and their boolean profunctors form a category denoted $\mathbf{BoolProf}$. \square

TERMINOLOGY 2.1.40 (Underlying relations of boolean profunctors). The ‘underlying relation functor’ $\text{rel} : \mathbf{BoolProf} \rightarrow \mathbf{Rel}$ takes preorders to their object sets, and boolean profunctors $R : X \dashv\vdash Y$ to the relation $R^{-1}(\top) \subset X \times Y$. \square

The underlying relation functor is faithful; that is, a boolean profunctor $R : X^{\text{op}} \times Y \rightarrow \mathbf{Bool}$ is completely determined by its underlying set relation $\text{rel } R \subset X \times Y$. However, the functor is not full, but has image exactly those relations that are functorial for the preorder structure.

REMARK 2.1.41 (Boolean profunctors are functorial relations). Given a boolean profunctor $R : X^{\text{op}} \times Y \rightarrow \mathbf{Bool}$ between preorders, the underlying relation $\text{rel } R \subset X \times Y$ is functorial, and any functorial relation is the underlying relation of a boolean profunctor. \square

TERMINOLOGY 2.1.42 (Representability of boolean profunctors). A boolean profunctor $R : X \rightarrow Y$ is called ‘representable’ if it is of the form $\text{Hom}_Y(f-, -)$ for a functor $f : X \rightarrow Y$, and ‘corepresentable’ if it is of the form $\text{Hom}_X(-, f-)$ for a functor $f : Y \rightarrow X$. \square

REMARK 2.1.43 (Discrete representability is functionality). If X and Y are discrete preorders, then a (co)representable boolean profunctor $X \rightarrow Y$ is simply a (co)functional relation. \square

REMARK 2.1.44 (1-Truss maps and 1-truss bordisms as functors and profunctors). A 1-truss map $T \rightarrow S$ is in particular a *functor* $(T, \trianglelefteq) \rightarrow (S, \trianglelefteq)$ of the face order posets, while a 1-truss bordism $T \rightarrow S$ is in particular a (boolean) *profunctor* $(T, \trianglelefteq) \rightarrow (S, \trianglelefteq)$ of the face order posets. \square

2.1.2.2. Local phenomena in 1-truss functorial relations. We describe and illustrate various local phenomena that occur in functorial relations between 1-trusses: first examples of local forms that are indeed 1-truss bordisms, then examples that violate either bifunctionality or bimonotonicity and so fail to be 1-truss bordisms.

EXAMPLE 2.1.45 (Local forms of 1-truss bordisms). In [Figure 2.12](#) we illustrate some local behaviors in 1-truss bordisms. The top three are ‘collisions’ in the sense that two singular elements of the domain truss converge to the same singular element of the codomain truss. The bottom three are ‘creations’ in the sense that a new singular element appears in the codomain truss, with no singular element of the domain truss converging to it. The right two are also ‘collapses’ in the sense that the domain truss degenerates into the single singular element of the codomain truss.

The topological counterparts of each of these behaviors (which also inform the choice of terminology for these cases), in the context of stratified bundles of stratified intervals, are illustrated later in [Figure 4.7](#). \square

EXAMPLE 2.1.46 (Functorial relations that are only partially bifunctional). In [Figure 2.13](#) we illustrate three functorial relations between trusses that are not truss bordisms because they fail to be bifunctional. However, these failures are rather mild and fixable. Mild in the sense that the issue is that the singular function or regular function is only partially defined. Fixable in the sense that, by extending either the source or target truss, the relation can

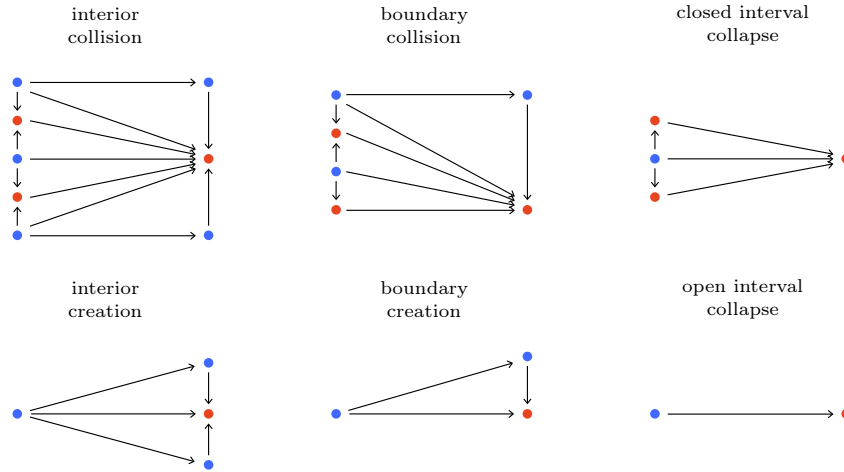

FIGURE 2.12. Local forms of 1-truss bordisms.

be completed to a truss bordism; in other words, the relation is a subrelation of an actual truss bordism.

In the first case, the regular upper endpoint of the special fiber is not related to any regular element of the generic fiber; this is an ‘upward discontinuity’ of the boundary of the truss. In the second case, the singular upper endpoint of the generic fiber is not related to any singular element of the special fiber, and moreover the special fiber has a singular upper endpoint; this is a ‘downward discontinuity’ of the boundary of the truss. In the third case, the singular upper endpoint of the generic fiber is not related to any singular element of the special fiber, but the upper endpoint of the special fiber is regular; this is a ‘boundary disappearance’ of the singular endpoint of the truss.

The topological counterparts of each of these relations, in the context of stratified bundles of stratified intervals, are illustrated later in Figure 4.8. \square

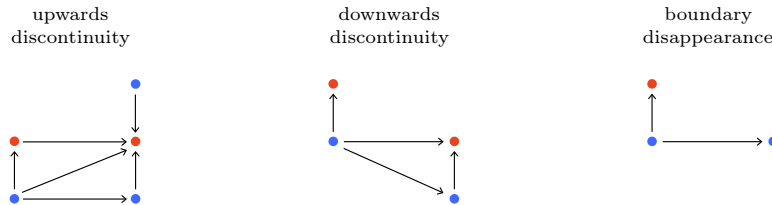

FIGURE 2.13. Fixable failures of truss bifunctionality.

EXAMPLE 2.1.47 (Functorial relations that are not bifunctional). In Figure 2.14 we illustrate three more functorial relations between trusses that are not truss bordisms, again because they fail to be bifunctional. Unlike the

cases in the previous example, these failures should be considered unrecoverable, most immediately because a singular element of the generic fiber is related to a regular element of the special fiber, violating the fundamental nature of truss bordisms.

In the first case, the interior singular element of the generic fiber is not related to any singular element of the special fiber, violating functionality, and worse is related to a regular element of the special fiber; furthermore, the regular element of the special fiber is related to two regular elements of the generic fiber, violating cofunctionality; this is an ‘interior evaporation’ of the singular element of the truss. In the second case, now a boundary singular element of the generic fiber is not related to any singular element (violating functionality) and indeed is related to a regular element of the special fiber; this is a ‘boundary evaporation’ of the singular endpoint of the truss. In the third case, the singular element of the generic fiber is related to two singular elements of the special fiber, violating functionality, and the regular element of the special fiber is not related to any regular element of the generic fiber, violating cofunctionality; this is a ‘point divergence’ of the singular element of the truss.

The topological counterparts of these relations, in the context of stratified bundles of stratified intervals, are illustrated later—the first and second relations here correspond to the first and second images in Figure 4.9, and the third relation here corresponds to the first image in Figure 4.10. \square

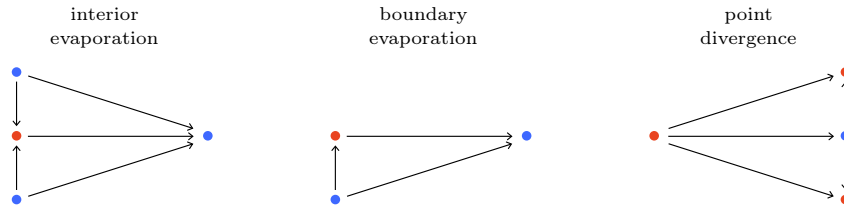

FIGURE 2.14. Irredeemable infractions of truss bifunctionality.

EXAMPLE 2.1.48 (Bifunctional functorial relations that are not bimonotone). In Figure 2.15 we illustrate two functorial relations between trusses that are bifunctional but are still not truss bordisms because they are not bimonotone. In the first case, the relation between the singular element of the generic fiber and the regular element of the special fiber causes a violation of bimonotonicity, despite not explicitly contravening bifunctionality; we refer to this situation as a ‘boundary dislocation’. (Note that by removing the relation between that singular element and that regular element, one obtains a subrelation that is in fact a truss bordism.) In the second case, the relation between the singular elements and the relation between the regular elements already violates bimonotonicity; we refer to this situation as a ‘boundary

divergence’. (Note that this case is especially pathological as it contains no subrelation whatsoever that is a truss bordism.)

The topological counterparts of these relations (which especially in this case clarify the terminology), in the context of stratified bundles of stratified intervals, are again illustrated later—the first relation here corresponds to the third image in Figure 4.9, and the second relation here corresponds to the second image in Figure 4.10. —



FIGURE 2.15. Brutal breakdowns of truss bimonotonicity.

2.1.2.3. Composition and dualization of 1-truss bordisms. 1-Trusses provide a combinatorial model of stratified intervals, and 1-truss bordisms provide a combinatorial model of suitable stratified bundles of stratified intervals, over the stratified 1-simplex. We may imagine stacking such stratified bundles end to end in an attempt to compose them, but unlike ordinary intervals, the union of two stratified intervals is not itself a stratified interval. In this case, in fact the combinatorial viewpoint provides a more evident composition than the geometric viewpoint. We need only observe that functorial relations compose and that the defining properties of 1-truss bordisms are preserved under this composition.

OBSERVATION 2.1.49 (Functorial relations compose). Given preorders X , Y , and Z , and functorial relations $R : X \leftrightarrow Y$ and $S : Y \leftrightarrow Z$, the composite relation $S \circ R : X \leftrightarrow Z$ is given by having a relation $(S \circ R)(x \in X, z \in Z)$ if and only if there is an element $y \in Y$ for which there are both relations $R(x, y)$ and $S(y, z)$. Note that the functoriality of R and S ensures that the composite relation $S \circ R$ is also functorial. —

OBSERVATION 2.1.50 (Bifunctionality and bimonotonicity compose). The properties of bifunctionality and bimonotonicity in Definition 2.1.33 are preserved under composition of functorial relations. Indeed, given 1-truss bordisms, $R : T \leftrightarrow T'$ and $R' : T' \leftrightarrow T''$, the functorial relation $R' \circ R : T \leftrightarrow T''$ is again bifunctional: its singular function is the composite $\text{sing}_{R'} \circ \text{sing}_R$, and its regular function is the composite $\text{reg}^{R'} \circ \text{reg}^R$. The relation $R' \circ R : T \leftrightarrow T''$ is also bimonotone: if there is a transposition of the composite $R' \circ R$ (with respect to the frame orders of T and T'') then there would necessarily be a transposition in at least one of the relations R or R' . —

Thus altogether, the composite of two 1-truss bordism functorial relations is itself a 1-truss bordism, as desired.

DEFINITION 2.1.51 (Composition of 1-truss bordisms). Given two 1-truss bordisms $R : T \rightarrow T'$ and $R' : T' \rightarrow T''$, the **composite 1-truss bordism** $R' \circ R : T \rightarrow T''$ is the composite of R and R' as functorial relations. \square

EXAMPLE 2.1.52 (Composition of 1-truss bordisms). In Figure 2.16 we illustrate a composition of two 1-truss bordisms. The bimonotonicity and bifunctionality of the composite relation are evident. \square

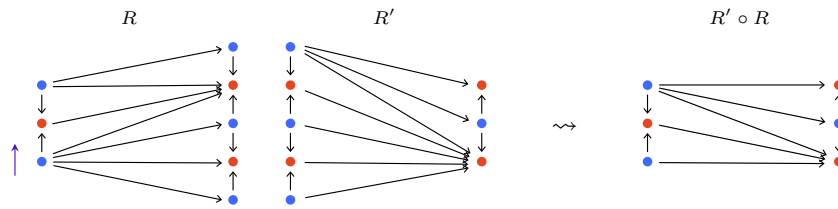

FIGURE 2.16. Composition of 1-truss bordisms.

There is an identity $\text{id}_T : T \rightarrow T$ for this composition of truss bordisms, namely the relation $\text{id}_T(a, b) \iff a \trianglelefteq b$ given by the face order of T . Thus 1-truss bordisms are morphisms of the following category.

NOTATION 2.1.53 (The category of 1-trusses and their bordisms). The ‘category of 1-trusses and their bordisms’, whose objects are 1-trusses and whose morphisms are 1-truss bordisms, will be denoted \mathbf{TBord}^1 . The full subcategory containing only open, respectively closed, 1-trusses will be denoted $\overset{\circ}{\mathbf{TBord}}^1$, respectively $\bar{\mathbf{TBord}}^1$. \square

OBSERVATION 2.1.54 (The terminal and initial 1-trusses). The terminal object of \mathbf{TBord}^1 is the trivial closed 1-truss $\bar{\mathbb{T}}_0$. The unique bordism $R : T \rightarrow \bar{\mathbb{T}}_0$ has a relation between every element of T and the unique (singular) element of $\bar{\mathbb{T}}_0$.

The initial object of \mathbf{TBord}^1 is the trivial open 1-truss $\overset{\circ}{\mathbb{T}}_0$. The unique bordism $R : \overset{\circ}{\mathbb{T}}_0 \rightarrow T$ has a relation between the unique (regular) element of $\overset{\circ}{\mathbb{T}}_0$ and every element of T . \square

OBSERVATION 2.1.55 (Isobordisms of 1-trusses are unique). We call a 1-truss bordism with an inverse a ‘1-truss isobordism’. Given two 1-trusses T and S , if there is an isobordism $R : T \rightarrow S$, then there is a unique such isobordism. There is therefore never any need to distinguish between distinct 1-trusses that are isomorphic in the category \mathbf{TBord}^1 . Also, in particular there are no nontrivial automorphisms in \mathbf{TBord}^1 . \square

REMARK 2.1.56 (Isobordism classes of 1-trusses). Note that the isomorphism classes of 1-trusses in \mathbf{TBord}^1 , that is the classes of 1-trusses up to

invertible bordism, are the same as the balanced isomorphism classes of 1-trusses, namely $\overset{\circ}{\mathbb{T}}_k$, $\bar{\mathbb{T}}_k$, $\overset{\circ}{\bar{\mathbb{T}}}_k$, and $\bar{\mathbb{T}}_k^{\circ}$; see [Terminology 2.1.23](#). —

Recall the dual T^\dagger of a 1-truss T has the same elements and frame order, but the opposite face order and dimension. As noted in [Construction 2.1.26](#), this dual extends to a covariant involutive functor $\dagger : \mathbf{Tr}_1 \cong \mathbf{Tr}_1$ on the category of 1-trusses and their maps. The same dual on 1-trusses also extends to a *contravariant* involutive functor on the category of 1-trusses and their bordisms, as follows.

CONSTRUCTION 2.1.57 (Dualization of 1-truss bordisms). Given a 1-truss bordism $R : T \rightarrow S$, the dual 1-truss bordism $R^\dagger : S^\dagger \rightarrow T^\dagger$ is the transpose relation:

$$R^\dagger(s, t) = R(t, s).$$

This transposed relation is functorial (since the face orders of the trusses have been reversed), bifunctional (since the singular and regular elements have been switched and so the roles of functionality and cofunctionality interchanged), and bimonotone (since the transpose introduces no transpositions of the frame order). Thus dualization provides an involutive isomorphism of categories

$$\dagger : \mathbf{TBord}^1 \cong (\mathbf{TBord}^1)^{\text{op}}$$

This dualization restricts to an isomorphism $\dagger : \overset{\circ}{\mathbf{TBord}}^1 \cong (\bar{\mathbf{TBord}}^1)^{\text{op}}$ between the category of open 1-trusses and their bordisms and the (opposite of the) category of closed 1-trusses and their bordisms. —

EXAMPLE 2.1.58 (Dual 1-truss bordisms). In [Figure 2.17](#) we depict a 1-truss bordism (the first one in the cospan of [Figure 2.11](#)) together with its dual 1-truss bordism. Notice how the transposed relation appears as a horizontal flip in this illustration, and the flipped singular function becomes the regular function, while the flipped regular function becomes the singular function. —

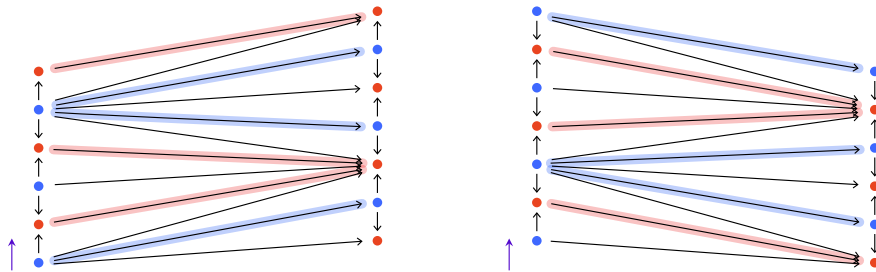

FIGURE 2.17. Dual 1-truss bordisms.

2.1.2.4. Determination of 1-truss bordisms. Functoriality, bifunctionality, and bimonotonicity collude to rigidly constrain the structure of 1-truss bordism relations. So much so that, subject to certain boundary conditions, these relations are completely determined either by their singular function or by their regular function. We collate a few features of 1-truss bordisms, leading up to this determination property.

OBSERVATION 2.1.59 (1-truss bordism relations weakly decrease dimension). Given a 1-truss bordism $R : T \rightarrow S$ with a relation $R(a, b)$ between elements $a \in T$ and $b \in S$, then $\dim(a) \geq \dim(b)$. In all preceding examples of 1-truss bordisms, it is visibly the case that relations are from singular to singular, regular to regular, or regular to singular elements, but never from singular to regular elements.

To prove that this is always the case, suppose by contrast that there were a relation $R(a, b)$ for singular $a \in T$ and regular $b \in S$. Consider the singular element $\text{sing}_R(a)$; since b is regular and frame orders are total, either $b \prec \text{sing}_R(a)$ or $\text{sing}_R(a) \prec b$. Assume the former; the latter case is similar. By bimonotonicity, we have $\text{reg}^R(b) \prec a$; thus there is at least one element below a in the frame order, and so there is a face order arrow $a - 1 \triangleleft a$ in (T, \trianglelefteq) . (Here $a - 1$ denotes the predecessor of a in the total frame order (T, \preceq) .) By the functoriality of the relation R , this implies that $R(a - 1, \text{sing}_R(a))$ holds. Since $a - 1 \prec a$, and $b \prec \text{sing}_R(a)$, and we assumed $R(a, b)$, this contradicts bimonotonicity. \square

Recall from Terminology 2.1.22 that the minimal and maximal elements of the frame order of a truss are called the lower and upper endpoints.

OBSERVATION 2.1.60 (1-truss bordisms relate endpoints). Given a 1-truss bordism $R : T \rightarrow S$, the lower endpoint of T is related to the lower endpoint of S , and the upper endpoint of T is related to the upper endpoint of S . In all the examples we have seen, this property is visible from the relation arrows between the bottommost and topmost elements.

To prove that this always holds, consider the lower endpoint case, as follows; the upper endpoint case is similar. Suppose the target lower endpoint end_S is regular. Set $a := \text{reg}^R(\text{end}_S)$. If $a = \text{end}_T$, then the endpoint relation is satisfied. Otherwise there is a predecessor of a , necessarily singular, and a relation $R(a - 1, \text{sing}_R(a - 1))$; bimonotonicity, and the regularity of end_S , forces $\text{sing}_R(a - 1) \prec \text{end}_S$, contradicting end_S being a lower endpoint. If instead we suppose the source lower endpoint end_T is singular, a dual argument shows that $\text{sing}_R(\text{end}_T) = \text{end}_S$, ensuring the endpoint relation is satisfied.

The only remaining case is when end_T is regular and end_S is singular. If both trusses have just one element, they are related, and the lower endpoints preserved, since the relation is nonempty by definition. Suppose T has at least two elements; the case when S has at least two elements is similar. Since T has some element above its lower endpoint, there is a singular successor $(\text{end}_T) + 1$ and a face order arrow $\text{end}_T \triangleleft (\text{end}_T) + 1$. If there is a relation

$R(\text{end}_-T + 1, \text{end}_-S)$, then by functoriality $R(\text{end}_-T, \text{end}_-S)$, as desired. Otherwise $R(\text{end}_-T + 1, \text{sing}_R((\text{end}_-T) + 1))$ with $\text{sing}_R((\text{end}_-T) + 1) \succ \text{end}_-S$. That forces there to be a regular successor $(\text{end}_-S) + 1$ and a face order arrow $(\text{end}_-S) + 1 \triangleleft \text{end}_-S$. By cofunctionality and bimonotonicity, there is a relation $R(\text{end}_-T, (\text{end}_-S) + 1)$ and so by functoriality a relation $R(\text{end}_-T, \text{end}_-S)$, as required. \square

The previous observation ensures that bordisms always relate endpoints. The singularity or regularity of these endpoints are interdependent, as follows.

OBSERVATION 2.1.61 (1-truss bordisms preserve singular endpoints and copreserve regular endpoints). Let $R : T \rightarrow S$ be a 1-truss bordism. If the lower (resp. upper) endpoint of T is singular, then the lower (resp. upper) endpoint of S is singular. If the lower (resp. upper) endpoint of S is regular, then the lower (resp. upper) endpoint of T is regular.

For the lower case (the upper case is similar), it suffices of course to confirm that it cannot happen that end_-T is singular while end_-S is regular; assume by contrast that this were the situation. If either T or S has only one element, the relation necessarily violates either singular functionality or regular cofunctionality. Thus there are face order arrows $(\text{end}_-T) + 1 \triangleleft \text{end}_-T$ and $\text{end}_-S \triangleleft (\text{end}_-S) + 1$. By **Observation 2.1.60**, there is an endpoint relation $R(\text{end}_-T, \text{end}_-S)$. Functoriality implies $R((\text{end}_-T) + 1, \text{end}_-S)$ and $R(\text{end}_-T, (\text{end}_-S) + 1)$ and $R((\text{end}_-T) + 1, (\text{end}_-S) + 1)$, violating bimonotonicity and reproducing the (vertical flip of the) boundary divergence of **Figure 2.15**. \square

Combining the previous two observations, note that in particular, for a 1-truss bordism $R : T \rightarrow S$, the singular function $\text{sing}_R : (\text{sing}(T), \preceq) \rightarrow (\text{sing}(S), \preceq)$ preserves singular endpoints, and the regular function $\text{reg}^R : (\text{reg}(S), \preceq) \rightarrow (\text{reg}(T), \preceq)$ preserves regular endpoints, in the following sense.

TERMINOLOGY 2.1.62 (Preserving singular or regular endpoints). Given 1-trusses T and S , a function $f : (\text{sing}(T), \preceq) \rightarrow (\text{sing}(S), \preceq)$ on the (frame ordered) singular elements is said to ‘preserve singular endpoints’ if any singular lower (resp. upper) endpoint of T is sent by the function to a singular lower (resp. upper) endpoint of S ; i.e. if $\text{end}_-(T) \in \text{sing}(T)$ then $f(\text{end}_-(T)) = \text{end}_-(S) \in \text{sing}(S)$, and similarly with end_+ in place of end_- .

Correspondingly, a function $g : (\text{reg}(S), \preceq) \rightarrow (\text{reg}(T), \preceq)$ is said to ‘preserve regular endpoints’ if any regular lower (resp. upper) endpoint of S is sent by the function to a regular lower (resp. upper) endpoint of T ; i.e. if $\text{end}_-(S) \in \text{reg}(S)$ then $g(\text{end}_-(S)) = \text{end}_-(T) \in \text{reg}(T)$, and similarly with end_+ in place of end_- . \square

In fact, finally, we can see that a function on the (frame ordered) singular elements determines a truss bordism, provided just that it is singular-endpoint preserving, and similarly a function on the (frame ordered) regular elements determines a truss bordism, provided just that it is regular-endpoint preserving, as follows.

LEMMA 2.1.63 (Bordisms determined by singular or regular functions).
 Let T and S be 1-trusses.

SINGULAR DETERMINED: Given a function $f : (\text{sing}(T), \preceq) \rightarrow (\text{sing}(S), \preceq)$ that preserves singular endpoints, there is a unique 1-truss bordism $R : T \rightarrow S$ with singular function $\text{sing}_R = f$.

REGULAR DETERMINED: Given a function $g : (\text{reg}(S), \preceq) \rightarrow (\text{reg}(T), \preceq)$ that preserves regular endpoints, there is a unique 1-truss bordism $R : T \rightarrow S$ with regular function $\text{reg}^R = g$.

PROOF. For the singular determined case, define the relation $R(a, b)$ to hold if and only if either (1) the element a is singular, and $b = f(a)$, or (2) the element a is regular, and both $f(a + 1) \succeq b$ (whenever $a + 1 \in T$) and $b \succeq f(a - 1)$ (whenever $a - 1 \in T$).

For the regular determined case, define the relation $R(a, b)$ to hold if and only if either (1) the element b is regular, and $a = g(b)$, or (2) the element b is singular, and both $g(b + 1) \succeq a$ (whenever $b + 1 \in S$) and $a \succeq g(b - 1)$ (whenever $b - 1 \in S$). \square

Since 1-truss bordism singular functions preserve singular endpoints, and 1-truss bordism regular functions preserve regular endpoints, all 1-truss bordisms are determined as in this lemma, and thus constructed as in the proof. That construction has the following consequences regarding the structure of 1-truss bordisms.

TERMINOLOGY 2.1.64 (Fully relating elements). We say a relation $R : T \rightarrow S$ ‘fully relates elements’ if for each $a \in T$ there exists $a' \in S$ with $R(a, a')$, and for each $b \in S$ there exists $b' \in T$ with $R(b', b)$. —

OBSERVATION 2.1.65 (1-Truss bordisms fully relate elements). Every 1-truss bordism fully relates elements. —

COROLLARY 2.1.66 (Correspondence of singular functionality and regular cofunctionality). Let T and S be 1-trusses, and let $R : (T, \triangleleft) \rightarrow (S, \triangleleft)$ be a functorial relation, that fully relates elements, and such that the relation $R \subset (T, \preceq) \times (S, \preceq)$ is bimonotone. The relation is functional on singular elements and preserves singular endpoints, if and only if it is cofunctional on regular elements and preserves regular endpoints. In this case, it is a 1-truss bordism.

PROOF. If the relation is functional on singular elements and preserves singular endpoints, its singular function determines a 1-truss bordism by the first case of Lemma 2.1.63. Observe that the given relation agrees with the 1-truss bordism constructed in the proof of that result, using crucially the assumptions of functoriality, fully relating elements, and bimonotonicity. The other direction is entirely similar. \square

2.1.2.5. Mapping cylinder 1-truss bordisms. As (stratified) manifolds are the objects of two rather different looking categories, namely manifolds with maps between them, and manifolds with bordisms between them, similarly we now have 1-trusses as the objects of these two distinct categories, namely 1-trusses and their maps Trs_1 , and 1-trusses and their bordisms TBord^1 . However, these categories are not entirely unrelated; the mapping cylinder of a suitable map of manifolds is a (singular, stratified, half) bordism, and similarly there is a mapping cylinder construction taking certain 1-truss maps to 1-truss bordisms.

The relevant 1-truss maps are those that respect the singularity or regularity of the boundary in the following sense.

NOTATION 2.1.67 (Categories of endpoint-preserving truss maps). A singular 1-truss map $F : T \rightarrow S$ is said to preserve singular endpoints if the restriction of the map to singular elements $F : \text{sing}(T) \rightarrow \text{sing}(S)$ preserves singular endpoints (see Terminology 2.1.62). Let $\text{Trs}_1^{s,\partial}$ denote the category of 1-trusses and their singular maps that preserve singular endpoints.

Similarly, a regular 1-truss map $G : S \rightarrow T$ is said to preserve regular endpoints if the restriction of the map to regular elements $G : \text{reg}(S) \rightarrow \text{reg}(T)$ preserves regular endpoints. Let $\text{Trs}_1^{r,\partial}$ denote the category of 1-trusses and their regular maps that preserve regular endpoints. —

CONSTRUCTION 2.1.68 (Mapping cylinders of singular and regular 1-truss maps). Given a singular map of 1-trusses $F : T \rightarrow S$, that preserves singular endpoints, Lemma 2.1.63 defines a (uniquely determined) 1-truss bordism $T \rightarrow S$ with singular function $F : \text{sing}(T) \rightarrow \text{sing}(S)$. We denote that bordism $\text{Cyl}(F) : T \rightarrow S$ and refer to it informally as the ‘mapping cylinder’ of the 1-truss map F . This construction assembles into a functor

$$\text{Cyl} : \text{Trs}_1^{s,\partial} \rightarrow \text{TBord}^1$$

Similarly, given a regular map of 1-trusses $T \leftarrow S : G$, that preserves regular endpoints, Lemma 2.1.63 defines a (uniquely determined) 1-truss bordism $T \leftarrow S$ with regular function $\text{reg}(T) \leftarrow \text{reg}(S) : G$. We denote that bordism $\text{coCyl}(G) : T \leftarrow S$ and refer to it informally as the ‘mapping cocylinder’ of the 1-truss map G . This construction assembles into a functor

$$\text{coCyl} : (\text{Trs}_1^{r,\partial})^{\text{op}} \rightarrow \text{TBord}^1 \quad \text{—}$$

EXAMPLE 2.1.69 (Mapping cylinders of 1-truss maps). In Figure 2.18 we illustrate 1-truss maps and their mapping (co)cylinders. The top left corner is a singular map, preserving singular endpoints. The top right corner is the mapping cylinder 1-truss bordism associated to that singular map. The lower left corner is the dual regular map (of the singular map), and it preserves regular endpoints. The lower right corner is both the mapping cocylinder 1-truss bordism associated to that regular map, and the dual 1-truss bordism of the top right bordism. —

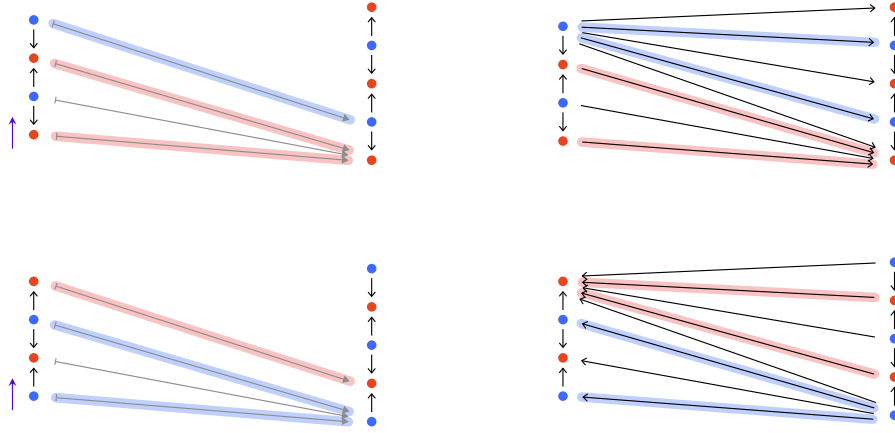

FIGURE 2.18. 1-truss maps and their mapping (co)cylinder 1-truss bordisms.

OBSERVATION 2.1.70 (Mapping cylinders commute with dualization). Given a singular map $F : T \rightarrow S$ of 1-trusses that preserves singular endpoints, we may take its mapping cylinder 1-truss bordism $\text{Cyl}(F) : T \rightarrow S$, and then form the dual 1-truss bordism $\text{Cyl}(F)^\dagger : T^\dagger \leftarrow S^\dagger$. Or we may take the dual regular map $F^\dagger : T^\dagger \rightarrow S^\dagger$ of 1-trusses, which preserves regular endpoints, and then form the mapping cocylinder 1-truss bordism $\text{coCyl}(F^\dagger) : T^\dagger \leftarrow S^\dagger$. As illustrated in the previous example, the resulting bordisms are identical. That is, mapping cylinders respect dualization in the sense that the following diagram commutes:

$$\begin{array}{ccc}
 \text{Trs}_1^{s,\partial} & \xrightarrow{\text{Cyl}} & \text{TBord}^1 \\
 \downarrow \dagger & & \downarrow \dagger \\
 \text{Trs}_1^{r,\partial} & \xrightarrow{\text{coCyl}} & (\text{TBord}^1)^{\text{op}}
 \end{array}$$

REMARK 2.1.71 (Mapping cylinders as represented functorial relations). When a singular or regular map of 1-trusses is more-or-less surjective, its mapping (co)cylinder is the relation (co)represented by the map, in the following sense (cf. Terminology 2.1.42).

Let $F : T \rightarrow S$ be a singular map of 1-trusses, such that the face order functor $F : (T, \trianglelefteq) \rightarrow (S, \trianglelefteq)$ is initial, i.e. for every element $s \in S$ there is an element $t \in T$ and a face order relation $F(t) \trianglelefteq s$; note that initiality implies this map preserves singular endpoints. In this case (only), the 1-truss bordism $\text{Cyl}(F)$, defined by Lemma 2.1.63, is precisely the functorial relation $\text{Hom}_{(S, \trianglelefteq)}(F-, -) : (T, \trianglelefteq) \rightarrow (S, \trianglelefteq)$ represented by the 1-truss map F .

Similarly, let $T \leftarrow S : G$ be a regular map of 1-trusses, such that the face order functor $(T, \trianglelefteq) \leftarrow (S, \trianglelefteq) : G$ is final, i.e. for every element $t \in T$ there is an element $s \in S$ and a face order relation $t \trianglelefteq G(s)$; note that

finality implies this map preserves regular endpoints. In this case (only), the 1-truss bordism $\text{coCyl}(G)$, defined by Lemma 2.1.63, is precisely the functorial relation $\text{Hom}_{(T, \trianglelefteq)}(-, G-): (T, \trianglelefteq) \leftrightarrow (S, \trianglelefteq)$ corepresented by the 1-truss map G . \square

2.1.3. 1-Truss bundles. In the previous section, we developed the notion of 1-truss bordisms, providing a combinatorial model of constructible bundles of stratified intervals over the stratified 1-simplex. Now we describe the notion of 1-truss bundle, which will provide a combinatorial model of constructible bundles of stratified intervals over not just the 1-simplex but over more general stratified spaces.

SYNOPSIS. We begin by defining 1-truss bundles as diposets each of whose point fibers is a 1-truss and each of whose arrow fibers is a 1-truss bordism. We introduce maps of 1-truss bundles, which are just base poset maps together with total diposet maps, and so in particular are maps of 1-trusses on each fiber. We show that the category of 1-trusses and their bordisms is a classifying category for 1-truss bundles; to any 1-truss bundle there is an associated classifying functor into the classifying category, and to any functor into the classifying category there is an associated total 1-truss bundle. Finally, we mention pullbacks of 1-truss bundles, observe that the dualization functors on 1-trusses extend to 1-truss bundles, and describe suspensions of 1-truss bundles.

2.1.3.1. 1-Truss bundles as collections of 1-truss bordisms. A 1-truss bundle over a poset will be a compatible collection of 1-truss bordisms, one over each arrow of the base poset. To describe the compatibility, it is convenient to encode the total object of the bundle itself as a poset, and to do that we need to recast the total object of a bordism as a poset, rather than as a relation.

TERMINOLOGY 2.1.72 (The associated total poset of a 1-truss bordism). By definition, a 1-truss bordism between 1-trusses T and S is a (bifunctional, bimonotone) functorial relation $R: (T, \trianglelefteq) \leftrightarrow (S, \trianglelefteq)$ of the face order posets. The ‘associated total poset’ of the 1-truss bordism R is the partial order $(T \sqcup S, \trianglelefteq)$, whose underlying set is the disjoint union of the 1-truss elements, and whose order relation \trianglelefteq has restriction to T being the face order (T, \trianglelefteq) , has restriction to S being the face order (S, \trianglelefteq) , and satisfies $(t \in T) \trianglelefteq (s \in S)$ if and only if the relation $R(t, s)$ holds. \square

Of course, only very special partial orders on the union of the source and target 1-trusses arise as the associated total posets of 1-truss bordisms; note that, for fixed domain and codomain 1-trusses, a partial order so arising completely determines the 1-truss bordism of which it is the associated total poset. Thus, we may and will lightly abuse terminology as follows.

NOTATION 2.1.73 (Total poset of a bordism). For a 1-truss bordism R (given by definition as a functorial relation), we refer without decoration to its associated total poset also simply as R . \square

Notice that already in our first illustration of a 1-truss bordism in Figure 2.9, we denoted each relation $R(t, s)$ by an arrow $t \rightarrow s$; as such, the collection of all arrows drawn (including those in the domain and codomain) is precisely the associated total poset of the 1-truss bordism.

We may now define 1-truss bundles, as suitably structured poset bundles, that restrict to 1-trusses over elements and to 1-truss bordisms over arrows.

DEFINITION 2.1.74 (1-Truss bundle). Let (B, \rightarrow) be a poset, and consider it to be a diposet $(B, \rightarrow, =)$ using the discrete order $=$. A **1-truss bundle** $(T, \trianglelefteq, \dim, \preceq, p)$ over (B, \rightarrow) is a diposet $(T, \trianglelefteq, \preceq)$, together with a poset map $\dim : (T, \trianglelefteq) \rightarrow [1]^{\text{op}}$, and a diposet map $p : (T, \trianglelefteq, \preceq) \rightarrow (B, \rightarrow, =)$, satisfying the following two conditions.

- (1) *Truss point fibers:* For every element $x \in B$, the fiber $(p^{-1}(x), \trianglelefteq, \dim, \preceq) \subset (T, \trianglelefteq, \dim, \preceq)$ is a 1-truss.
- (2) *Truss bordism arrow fibers:* For every arrow $x \rightarrow y$ in the base poset (B, \rightarrow) , the fiber $(p^{-1}(x \rightarrow y), \trianglelefteq) \subset (T, \trianglelefteq)$ is the total poset of a 1-truss bordism.

We call (B, \rightarrow) the ‘base poset’, call $(T, \trianglelefteq, \preceq)$ the ‘total diposet’ and (T, \trianglelefteq) the ‘total poset’, and as for 1-trusses, refer to \trianglelefteq as the ‘face order’, to \preceq as the ‘frame order’, and to \dim as the ‘dimension map’. —

NOTATION 2.1.75 (1-Truss bundles). When referring to 1-truss bundles, we will usually keep the face orders, frame orders, and dimension maps, as well as the base poset order, implicit; we thus denote 1-truss bundles simply by maps $p : T \rightarrow B$. When then referring to the structures of such a 1-truss bundle, we will use the symbol ‘ \trianglelefteq ’ for the face order, ‘ \preceq ’ for the frame order, ‘ \dim ’ for the dimension map, and ‘ \rightarrow ’ for the base poset order. We will also freely use an arrow ‘ \rightarrow ’, instead of \trianglelefteq , to indicate a face order relation, as this corresponds to our graphical illustration convention and is also nicely compatible with the order \rightarrow of the base poset. —

Note that in a 1-truss bundle $p : T \rightarrow B$, two elements $a, b \in T$ are related in the frame order if and only if they are in the same fiber $a, b \in p^{-1}(x)$: no elements of distinct fibers can be frame-order related since $p : (T, \preceq) \rightarrow (B, =)$ is a poset map, and frame orders are total on each fiber 1-truss.

TERMINOLOGY 2.1.76 (Singular and regular elements of 1-truss bundles). Given a 1-truss bundle $p : T \rightarrow B$, we call an element $a \in T$ ‘singular’ if $\dim(a) = 0$ and ‘regular’ if $\dim(a) = 1$. We denote by $\text{sing}(T)$, respectively $\text{reg}(T)$, the full subposet of (T, \trianglelefteq) containing all singular, respectively regular, elements. (We also freely think of $\text{sing}(T)$ and $\text{reg}(T)$ as the full subdiposets of $(T, \trianglelefteq, \preceq)$ on the same elements.) —

TERMINOLOGY 2.1.77 (Open and closed 1-truss bundles). A 1-truss bundle for which all fibers are open, respectively closed, 1-trusses, will be called an ‘open’, respectively ‘closed’, 1-truss bundle. —

EXAMPLE 2.1.78 (1-Truss bundle). In Figure 2.19, on the left we illustrate a 1-truss bundle $p : T \rightarrow B$. As before, singular elements are shown as red

dots, and regular elements as blue dots. The face order of the total poset (T, \trianglelefteq) is indicated by arrows, as is the poset order of the base. The total frame order of each fiber is indicated by a purple coordinate axis vector. (Note that we choose all such axes to point in the same, upwards direction. Flipping all these frame axes to point downward would produce a distinct 1-truss bundle.) ┌

TERMINOLOGY 2.1.79 (Generating arrows of 1-truss bundles). A ‘generating arrow’ of a 1-truss bundle is an arrow in the covering relation of the total poset of the bundle, i.e. a non-identity arrow that is not a composite of other non-identity arrows. ┌

EXAMPLE 2.1.80 (Generating arrows of a 1-truss bundle). As pictures of 1-truss bundles can quickly become difficult to parse, from so many arrows, we often illustrate them more sparsely by only drawing the generating arrows. On the right of Figure 2.19, we depict the same bundle as on the left, but omit all composite arrows. ┌

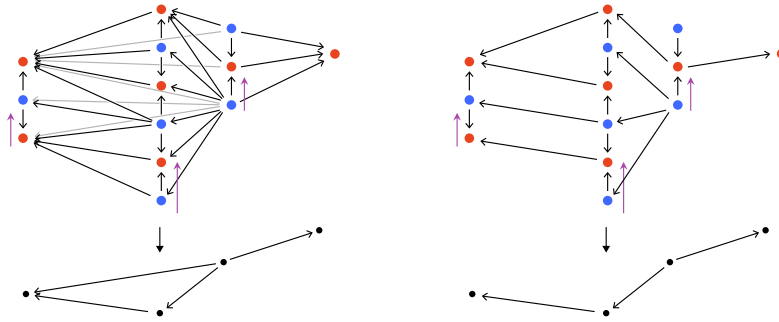

FIGURE 2.19. A 1-truss bundle and its generating arrows.

CONSTRUCTION 2.1.81 (Generating arrows in 1-truss bundles). Given a 1-truss bundle $p : T \rightarrow B$, its set of generating arrows is completely and concisely determined as follows. Let $\text{cov}(B)$ denote the covering relation of the base poset. An arrow $a \rightarrow b$ of the total poset (T, \trianglelefteq) is generating if and only if:

- › either $p(a \rightarrow b) = \text{id}$ (i.e. the arrow lies in a fiber of the projection p),
- › or $p(a \rightarrow b) \in \text{cov}(B)$ and either $(a \rightarrow b) \in \text{sing}(T)$ or $(a \rightarrow b) \in \text{reg}(T)$ (i.e. the arrow has source and target of the same dimension) or $a \rightarrow b$ is the unique arrow of the fiber over the arrow $p(a \rightarrow b)$ of the base (cf. open interval collapse in Figure 2.12). ┌

REMARK 2.1.82 (Flip action on frame orders). As mentioned in Example 2.1.78, there is a \mathbb{Z}_2 action on the collection of 1-truss bundles by flipping the frame order of every fiber. As this flip tends to not alter the essential behavior in question, we usually depict frame orders of bundles only up to

this action; specifically, we position the fibers of the bundle parallel, and assume the fiber frame orders run in the same direction, but typically do not fix which direction. \square

OBSERVATION 2.1.83 (Arrows lift in 1-truss bundles). Let $p : T \rightarrow B$ be a 1-truss bundle. Given an arrow $x \rightarrow y$ in the base B , and a lift of x to an element $a \in T$, the arrow lifts to some arrow $a \rightarrow a'$ of the total poset. Similarly, given a lift of y to an element $b \in T$, the arrow lifts to some arrow $b' \rightarrow b$. Both properties follow immediately from [Observation 2.1.65](#). \square

OBSERVATION 2.1.84 (Unique singular or regular lifts in 1-truss bundles). The lifts in the previous observation become unique if we insist they are singular (in the first case) or regular (in the second case). Specifically, given a 1-truss bundle $p : T \rightarrow B$, an arrow $x \rightarrow y$ in the base, and a lift of x to a singular element $a \in T$, there is a unique lift to an arrow $a \rightarrow a'$ in $\text{sing}(T)$. (In categorical terms, the functor $p : \text{sing}(T) \rightarrow B$ is a ‘discrete opfibration’ [[LR20](#), [MLM92](#)].) Similarly, given a lift of y to a regular element $b \in T$, there is a unique lift to an arrow $b' \rightarrow b$ in $\text{reg}(T)$. (The functor $p : \text{reg}(T) \rightarrow B$ is a ‘discrete fibration’.) These properties follow from the bifunctionality of 1-truss bordisms. \square

The definition of 1-truss bundles has a natural generalization allowing the base to be a category, not just a poset.

REMARK 2.1.85 (Categorical 1-truss bundles). Our [Definition 2.1.74](#) restricts attention to base *posets*, as that context will be our exclusive concern, and so gives a notion of *posetal* 1-truss bundle. However, the definition can be recast to accommodate base *categories*, yielding a notion of *categorical* 1-truss bundles. To wit, a ‘categorical 1-truss bundle’ is a functor $p : \mathbb{T} \rightarrow \mathbb{B}$ to a base category \mathbb{B} , equipped with 1-truss structures on the fibers over objects, such that the fibers over morphisms are 1-truss bordisms. \square

EXAMPLE 2.1.86 (Categorical 1-truss bundle). In [Figure 2.20](#) we illustrate a 1-truss bundle over a category that is not a poset. Note that the 1-truss bordisms over the two parallel morphisms of the base are crucially distinct. A topological counterpart of this categorical 1-truss bundle is illustrated in [Figure 4.6](#). \square

2.1.3.2. Maps of 1-truss bundles. Recall that a map of 1-trusses is a diposet map, that is, a map of sets that respects both the face order and the frame order. A map of 1-truss bundles is simply a map of the total diposets, which in particular then is a map of 1-trusses on each fiber, as follows.

DEFINITION 2.1.87 (Maps of 1-truss bundles). For 1-truss bundles $p : T \rightarrow B$ and $q : S \rightarrow C$, a **map of 1-truss bundles** $F : p \rightarrow q$ is a (base) poset map $G : (B, \rightarrow) \rightarrow (C, \rightarrow)$ and a (total) diposet map $F : (T, \triangleleft, \preceq) \rightarrow (S, \triangleleft, \preceq)$, commuting with the projections to the bases; that is, the following square

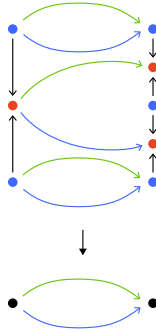

FIGURE 2.20. A 1-truss bundle over a category.

commutes:

$$\begin{array}{ccc}
 T & \xrightarrow{F} & S \\
 p \downarrow & & \downarrow q \\
 B & \xrightarrow{G} & C
 \end{array}$$

When the base map is the identity, $G = \text{id}_B$, we say that $F : p \rightarrow q$ is a map of 1-truss bundles ‘over the base B ’ or that it is ‘base preserving’. \square

Note that in a 1-truss bundle map, the base poset map $G : (B, \rightarrow) \rightarrow (C, \rightarrow)$ is uniquely determined by the total diposet map $F : (T, \triangleleft, \preceq) \rightarrow (S, \triangleleft, \preceq)$. Also note that a 1-truss bundle map $F : p \rightarrow q$ is a 1-truss map on each fiber; that is, for each $x \in B$, the restriction $F : p^{-1}(x) \rightarrow q^{-1}G(x)$ is a 1-truss map.

TERMINOLOGY 2.1.88 (Singular, regular, and balanced 1-truss bundle maps). Let $F : p \rightarrow q$ be a map of 1-truss bundles. If the total diposet map $F : (T, \triangleleft, \preceq) \rightarrow (S, \triangleleft, \preceq)$ sends the singular subposet $\text{sing}(T)$ to $\text{sing}(S)$, we call F a ‘singular’ bundle map; similarly if it maps $\text{reg}(T)$ to $\text{reg}(S)$, we call it a ‘regular’ bundle map; if F is both singular and regular, then we call it a ‘balanced’ bundle map. (Equivalently, a bundle map is singular or regular or balanced if it is so on every fiber.) \square

EXAMPLE 2.1.89 (1-Truss bundle maps). In Figure 2.21 we illustrate two 1-truss bundle maps. In the first case on the left, the base poset map is indicated by grey arrows; its source is the open truss with five elements and its target is the open truss with three elements. The total poset map is also indicated with grey arrows, of corresponding tonal densities. Note that this 1-truss bundle map is singular: the seven central singular elements of the source all collapse to the single central singular element of the target.

In the second case on the right, the base poset map is the identity of the open truss with five elements. The total poset map is again indicated with correspondingly grey arrows. Note that this 1-truss bundle map is regular: in

the central slice all three regular elements of the source merge into the central regular element of the target, while in each of the adjacent slices, two regular elements of the source merge into a regular element of the target. \square

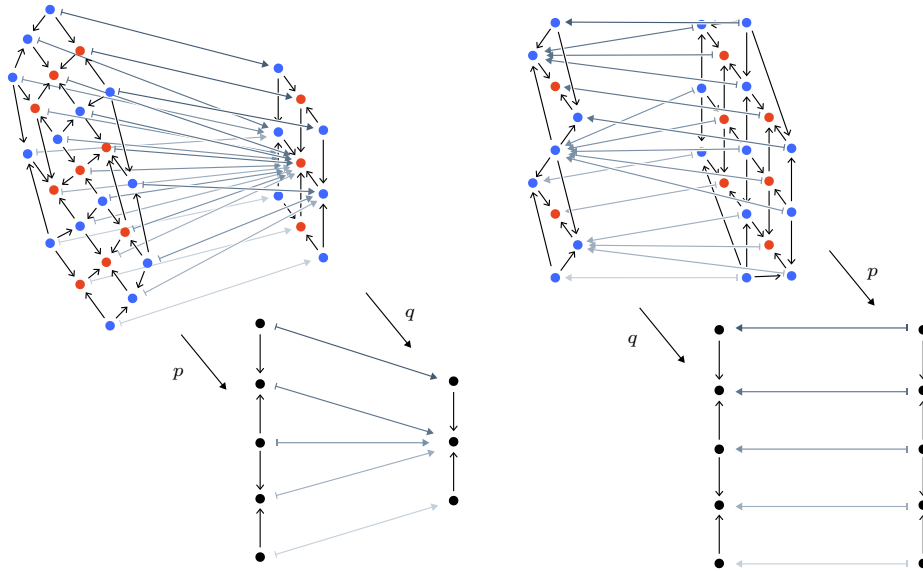

FIGURE 2.21. A singular and a regular 1-truss bundle map.

NOTATION 2.1.90 (Categories of 1-truss bundles). The category of 1-truss bundles and their maps is denoted TrsBun_1 . The subcategory of bundles over a fixed base poset B and their base-preserving maps is denoted $\text{Trs}_1(B)$. The subcategory of $\text{Trs}_1(B)$ containing open truss bundles and their regular maps is denoted $\overset{\circ}{\text{Trs}}_1(B)$; similarly the subcategory of $\text{Trs}_1(B)$ containing closed truss bundles and their singular maps is denoted $\bar{\text{Trs}}_1(B)$. \square

TERMINOLOGY 2.1.91 (Restriction of 1-truss bundles). Given a 1-truss bundle $p : T \rightarrow B$ and a subposet $A \hookrightarrow B$, the ‘restriction’ of the bundle to the subposet is the 1-truss bundle $p|_A : T|_A \rightarrow A$ with total set $T|_A := p^{-1}A$, and with the diposet structure, dimension map, and projection restricted accordingly. This process provides a restriction functor $-|_A : \text{Trs}_1(B) \rightarrow \text{Trs}_1(A)$.

2.1.3.3. Classification and totalization for 1-truss bundles. Essentially by definition, 1-truss bundles over a point are 1-trusses, 1-truss bundles over the interval poset $[1]$ are 1-truss bordisms, and 1-truss bundles over general base posets B are characterized by their behavior over points and intervals of the base. It follows, as we will describe in detail presently, that the category of 1-trusses and their bordisms TBord^1 is a *classifying category* for 1-truss bundles (see [Bén67]); that is, there is a correspondence between

1-truss bundles $p : T \rightarrow B$ over a base poset B and functors $F : B \rightarrow \mathbf{TBord}^1$ from the base poset into the category of 1-trusses and their bordisms.

CONSTRUCTION 2.1.92 (Classifying functors of 1-truss bundles). We describe a map

$$(p : T \rightarrow B) \mapsto (\chi_p : B \rightarrow \mathbf{TBord}^1)$$

that takes a 1-truss bundle p to an associated **classifying functor** χ_p .

We construct χ_p on elements and arrows of the poset B , as follows. For each element $x \in B$, the classifying element $\chi_p(x) \in \mathbf{TBord}^1$ is the point fiber 1-truss $p^{-1}(x)$; for each arrow $x \rightarrow y$ in the base B , the classifying morphism $\chi_p(x \rightarrow y)$ of \mathbf{TBord}^1 is the arrow fiber 1-truss bordism $p^{-1}(x \rightarrow y)$ (as given in Definition 2.1.74).

To see that the given χ_p is indeed a functor, one checks that the 1-truss bordism composite $p^{-1}(y \rightarrow z) \circ p^{-1}(x \rightarrow y)$ is equal to the 1-truss bordism $p^{-1}(x \rightarrow z)$. By the definition of composition of functorial relations, and because the total poset (T, \trianglelefteq) is closed under composition of arrows, the bordism $p^{-1}(y \rightarrow z) \circ p^{-1}(x \rightarrow y)$ is a subrelation of the bordism $p^{-1}(x \rightarrow z)$; however, a 1-truss bordism admits no proper subbordism, so the two must be equal. —

CONSTRUCTION 2.1.93 (Total 1-truss bundles of classifying functors). We describe a map

$$(F : B \rightarrow \mathbf{TBord}^1) \mapsto (\pi_F : \text{Tot}F \rightarrow B)$$

that takes a functor $F : B \rightarrow \mathbf{TBord}^1$ from a poset B to the category of 1-truss bordisms to an associated **total 1-truss bundle** $\pi_F : \text{Tot}F \rightarrow B$.

We construct the bundle π_F as follows.

- › The total poset $(\text{Tot}F, \trianglelefteq)$ has elements the pairs $(x \in B, a \in F(x))$ of an element of the poset and an element of the associated 1-truss; the total poset has a morphism $(x, a) \trianglelefteq (y, b)$ exactly when the 1-truss bordism $F(x \rightarrow y)$ has a relation between the element $a \in F(x)$ and $b \in F(y)$.
- › The frame order $(\text{Tot}F, \preceq)$ has a relation $(x, a) \preceq (x, b)$ exactly when $a \preceq b$ in $F(x)$.
- › The diposet map $\pi_F : (\text{Tot}F, \trianglelefteq, \preceq) \rightarrow (B, \rightarrow, =)$ is of course the projection sending (x, a) to x .
- › The dimension map $\dim : (\text{Tot}F, \trianglelefteq) \rightarrow [1]^{\text{op}}$ is given on each fiber by the dimension map of that 1-truss fiber; that this defines a poset map on $(\text{Tot}F, \trianglelefteq)$ follows from Observation 2.1.59 that 1-truss bordisms weakly decrease dimension. —

EXAMPLE 2.1.94 (Classification for a 1-truss bundle). In Figure 2.22 we illustrate on the left a 1-truss bundle $p : T \rightarrow B$ (over a 1-truss as it happens), along with on the right its associated classifying functor $\chi_p : B \rightarrow \mathbf{TBord}^1$. (The inverse association taking that functor $F : B \rightarrow \mathbf{TBord}^1$ to its total bundle $\pi_F : \text{Tot}F \rightarrow B$ is also indicated.) In the classifying category \mathbf{TBord}^1 ,

we only depict the image of this particular functor, namely the trusses $\overset{\circ}{\mathbb{T}}_1$ and $\bar{\mathbb{T}}_1$ and the morphisms between them. The functor χ_p is indicated by color matching the morphisms of the base poset B with their images. \square

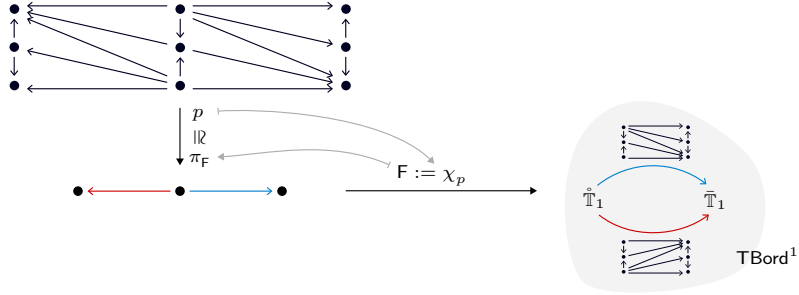

FIGURE 2.22. A 1-truss bundle and its classifying functor.

EXAMPLE 2.1.95 (The composition of 1-truss bordisms as a 1-truss bundle over the 2-simplex). Two composable 1-truss bordisms $R : T \rightarrow T'$ and $R' : T' \rightarrow T''$, together with their composite $R' \circ R : T \rightarrow T''$, define a functor $F : [2] \rightarrow \mathbf{TBord}^1$ from the 2-simplex poset $[2]$ to the category of 1-trusses and their bordisms. By the previous construction, this functor has an associated total 1-truss bundle $\pi_F : \text{Tot}F \rightarrow [2]$ over the 2-simplex.

In Figure 2.16 we illustrated two composable 1-truss bordisms along with their composite. In Figure 2.23 we illustrate the associated total 1-truss bundle over the 2-simplex. \square

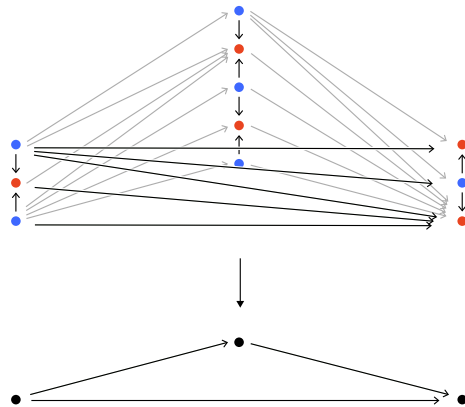

FIGURE 2.23. 1-Truss bordism composition as a bundle over the 2-simplex.

The above correspondence, between 1-truss bundles and functors into the category of 1-trusses and their bordisms, is functorial, with respect to a notion of bordism of 1-truss bundles, as follows.

DEFINITION 2.1.96 (Bordisms of 1-truss bundles and their composition). Given 1-truss bundles $p : T \rightarrow B$ and $q : S \rightarrow B$ over a poset B , a **1-truss bundle bordism** $u : p \rightarrow q$ is a 1-truss bundle $u : U \rightarrow B \times [1]$ such that $u|_{B \times \{0\}} = p$ and $u|_{B \times \{1\}} = q$.

The **composition** of two 1-truss bundle bordisms $u : p \rightarrow q$ and $v : q \rightarrow r$ is the bordism $v \circ u : p \rightarrow r$ whose restriction $(v \circ u)|_{\{x\} \times [1]}$ is the composite bordism $v|_{\{x\} \times [1]} \circ u|_{\{x\} \times [1]}$, for all elements $x \in B$. ---

When the base poset B is trivial, a 1-truss bundle bordism is simply a 1-truss bordism.

NOTATION 2.1.97 (Category of 1-truss bundles and their bordisms). For a fixed base poset B , the ‘category of 1-truss bundles and their bordisms’, whose objects are 1-truss bundles over B and whose morphisms are 1-truss bundle bordisms, will be denoted $\mathbf{TBord}^1(B)$. ---

OBSERVATION 2.1.98 (Isobordisms of 1-truss bundles are unique). A 1-truss bundle bordism that has an inverse is called a ‘1-truss bundle isobordism’. As a bundle analog of [Observation 2.1.55](#), note that, given two 1-truss bundles, if there is an isobordism between them, then there is a unique such isobordism. There is therefore no need to distinguish between distinct 1-truss bundles that are isomorphic in the category $\mathbf{TBord}^1(B)$. ---

REMARK 2.1.99 (Isobordism classes of 1-truss bundles). As a bundle analog of [Remark 2.1.56](#), note that the isomorphism classes of 1-truss bundles in $\mathbf{TBord}^1(B)$, that is the classes of 1-truss bundles up to invertible bordism, are the same as the classes of 1-truss bundles up to base-preserving balanced isomorphism. ---

Of course there is a category of functors from a base poset B to the category \mathbf{TBord}^1 of 1-trusses and their bordisms, whose morphisms are natural transformations of functors; note that a natural transformation $\mathbf{N} : \mathbf{F} \Rightarrow \mathbf{G}$ between functors $\mathbf{F} : B \rightarrow \mathbf{TBord}^1$ and $\mathbf{G} : B \rightarrow \mathbf{TBord}^1$ is simply itself a functor $\mathbf{N} : B \times [1] \rightarrow \mathbf{TBord}^1$.

Having now a suitable category of 1-truss bundles and their bordisms, and a suitable category of classifying functors, we can describe the functorial correspondence.

OBSERVATION 2.1.100 (Classification and totalization functors for 1-truss bundles). Given a poset B , there is an equivalence of categories

$$\chi_- : \mathbf{TBord}^1(B) \rightleftarrows \mathbf{Fun}(B, \mathbf{TBord}^1) : \pi_-$$

specified as follows.

The ‘classification functor’ χ_- takes a 1-truss bundle $p : T \rightarrow B$ to its classifying functor $\chi_p : B \rightarrow \mathbf{TBord}^1$, and a 1-truss bundle bordism $u : p \rightarrow q$ (by definition a 1-truss bundle over $B \times [1]$) to its classifying functor $\chi_u : B \times [1] \rightarrow \mathbf{TBord}^1$ viewed as a natural transformation $\chi_u : \chi_p \Rightarrow \chi_q$.

The ‘totalization functor’ π_- takes a functor $F : B \rightarrow \mathbf{TBord}^1$ to its total 1-truss bundle $\pi_F : \text{Tot}F \rightarrow B$, and a natural transformation $N : B \times [1] \rightarrow \mathbf{TBord}^1$ to its total 1-truss bundle $\pi_N : \text{Tot}N \rightarrow B \times [1]$. —

REMARK 2.1.101 (1-Truss bundle totalization and classification as collage and decollage). Recall the classical ‘Grothendieck’, i.e. ‘total category’ construction provides, for a category \mathbf{C} , a correspondence between suitable opfibrations $D \rightarrow C$ and classifying functors $C \rightarrow \mathbf{Cat}$. The above correspondence, between 1-truss bundles and classifying functors to the category of 1-trusses and their bordisms, is not a version of that Grothendieck correspondence, because truss bordisms are not functors of 1-trusses but relations between them. However, there is a ‘profunctorial Grothendieck’, i.e. ‘collage’ construction providing a correspondence between suitable exponentiable functors $D \rightarrow C$ and classifying (pseudo)functors $C \rightsquigarrow \mathbb{P}\text{rof}$ landing not in the bicategory of categories and functors and natural transformations but in the bicategory $\mathbb{P}\text{rof}$ of categories and profunctors and natural transformations; see for instance [Bén00, Str01, Bén67, Bor94]. The above 1-truss bundle totalization and classification constructions are a combinatorial version of this collage correspondence, tailored for our purposes. —

REMARK 2.1.102 (Classifying categorical 1-truss bundles). Recall from Remark 2.1.85 that there is a notion of categorical 1-truss bundle $p : T \rightarrow B$ over a base category B . The above classification and totalization constructions carry over to the categorical case, showing that 1-truss bundles over a category B (and their bundle bordisms) correspond to functors $B \rightarrow \mathbf{TBord}^1$ (and their natural transformations). —

2.1.3.4. Pullback, dualization, and suspension of 1-truss bundles.

With the notions of classification and totalization in hand, we describe three further constructions on 1-truss bundles.

CONSTRUCTION 2.1.103 (Pullback of 1-truss bundles). Given a 1-truss bundle $p : T \rightarrow B$ and any poset map $G : A \rightarrow B$, the pullback of the bundle (along the map G) is the 1-truss bundle $G^*p : G^*T \rightarrow A$, together with the 1-truss bundle map $(\text{Tot}G, G) : G^*p \rightarrow p$, determined as follows. The total poset $(G^*T, \trianglelefteq) := G^*(T, \trianglelefteq)$ is the pullback in the category of posets, with the resulting projection $G^*p : (G^*T, \trianglelefteq) \rightarrow (A, \rightarrow)$ and total map $\text{Tot}G : (G^*T, \trianglelefteq) \rightarrow (T, \trianglelefteq)$; the frame order and dimension map on G^*T are such that the total map $\text{Tot}G$ is a 1-truss isomorphism on each fiber. —

Of course, when the poset map $G : A \hookrightarrow B$ is a subposet inclusion, the pullback specializes to the restriction of the 1-truss bundle, that is $G^*p = p|_A$.

NOTATION 2.1.104 (Pullback 1-truss bundles). Altogether, the pullback 1-truss bundle and its associated maps are concisely indicated by the usual

pullback corner caret:

$$\begin{array}{ccc}
 G^*T & \xrightarrow{\text{Tot}G} & T \\
 G^*p \downarrow & \lrcorner & \downarrow p \\
 A & \xrightarrow{G} & B
 \end{array}
 \quad \lrcorner$$

EXAMPLE 2.1.105 (Pullback 1-truss bundle). In Figure 2.24 we illustrate a pullback, in fact a restriction, of a 1-truss bundle. —

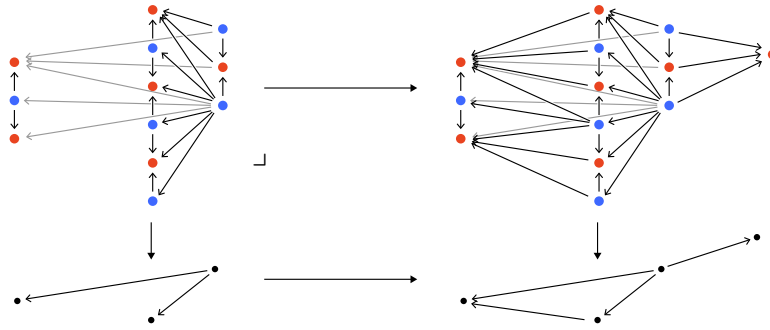

FIGURE 2.24. The pullback of a 1-truss bundle along a base poset inclusion.

REMARK 2.1.106 (Pullback bundles via classifying functors). The pullback bundle may be reexpressed in terms of classifying functors. Given a 1-truss bundle $p : T \rightarrow B$ with classifying functor $\chi_p : B \rightarrow \mathbf{TBord}^1$, and a poset map $G : A \rightarrow B$, the pullback bundle $G^*p : G^*T \rightarrow A$ has classifying functor the composite $\chi_p \circ G : A \rightarrow \mathbf{TBord}^1$. In other words, the pullback is the total bundle of the composite classifying functor: $G^*p = \pi_{\chi_p \circ G}$. —

Dualizing 1-trusses fiberwise provides a dualization of 1-truss bundles, as follows.

CONSTRUCTION 2.1.107 (Dualization of 1-truss bundles and their maps). Given a 1-truss bundle $p : T \rightarrow B$ with total diposet $(T, \triangleleft, \trianglelefteq)$, dimension map $\dim : (T, \triangleleft) \rightarrow [1]^{\text{op}}$, and projection $p : (T, \triangleleft, \trianglelefteq) \rightarrow (B, \rightarrow, =)$, its ‘dual 1-truss bundle’ $p^\dagger : T^\dagger \rightarrow B^{\text{op}}$ has total diposet $T^\dagger := (T, \trianglelefteq^{\text{op}}, \triangleleft)$, dimension map the composite $(T, \trianglelefteq^{\text{op}}) \xrightarrow{\dim^{\text{op}}} [1] \cong [1]^{\text{op}}$, and projection $p^\dagger : (T, \trianglelefteq^{\text{op}}, \triangleleft) \rightarrow (B, \rightarrow^{\text{op}}, =)$ elementwise equal to the original projection p . That is, as when dualizing 1-trusses, the dual bundle has opposite face order and dimension map, while the frame order is unchanged.

Given a 1-truss bundle map $F : (p : T \rightarrow B) \rightarrow (q : S \rightarrow C)$, the ‘dual 1-truss bundle map’ $F^\dagger : (p^\dagger : T^\dagger \rightarrow B^{\text{op}}) \rightarrow (q^\dagger : S^\dagger \rightarrow C^{\text{op}})$ is the map $F^\dagger : (T, \trianglelefteq^{\text{op}}, \triangleleft) \rightarrow (S, \trianglelefteq^{\text{op}}, \triangleleft)$ whose underlying map of sets is equal to the

underlying map of sets of the bundle map F itself. We have therefore a covariant involutive functor

$$\dagger : \text{TrsBun}_1 \cong \text{TrsBun}_1.$$

Note that this functor does not preserve the base of the bundle. It does though restrict to the earlier dualization of 1-trusses from [Construction 2.1.26](#), when the base is a point. \square

As for dualization of 1-trusses, dualization takes open 1-truss bundles to closed 1-truss bundles and vice versa, and takes singular bundle maps to regular bundle maps and vice versa.

We have not only a covariant dualization functor on bundles and their maps, but also a contravariant dualization functor on bundles and their bordisms.

CONSTRUCTION 2.1.108 (Dualization of 1-truss bundles and their bordisms). Given a 1-truss bundle bordism $u : p \rightarrow q$ given by the 1-truss bundle $u : U \rightarrow B \times [1]$, the ‘dual 1-truss bundle bordism’ $u^\dagger : q^\dagger \rightarrow p^\dagger$ is given by the 1-truss bundle $u^\dagger : U^\dagger \rightarrow (B \times [1])^{\text{op}} \cong B^{\text{op}} \times [1]$. Note that the flip of variance of the whole base poset $B \times [1]$ flips the direction of the bordism. Dualization therefore gives an involutive isomorphism

$$\dagger : \text{TBord}^1(B) \cong \text{TBord}^1(B^{\text{op}})^{\text{op}}.$$

When the base is a point, this specializes to the dualization of 1-truss bordisms $\dagger : \text{TBord}^1 \rightarrow (\text{TBord}^1)^{\text{op}}$, given in [Construction 2.1.57](#). \square

REMARK 2.1.109 (Dual bundles via classifying functors). The dual bundle may be reexpressed using classifying functors. Given a 1-truss bundle $p : T \rightarrow B$, with classifying functor $\chi_p : B \rightarrow \text{TBord}^1$, its dual $p^\dagger : T^\dagger \rightarrow B^{\text{op}}$ has classifying functor

$$(\chi_{p^\dagger} : B^{\text{op}} \rightarrow \text{TBord}^1) = (B \xrightarrow{\chi_p} \text{TBord}^1 \xrightarrow{\dagger} (\text{TBord}^1)^{\text{op}})^{\text{op}}.$$

Indeed this association of classifying functors $\chi_p \mapsto (\dagger \circ \chi_p)^{\text{op}}$ is functorial and reproduces the involutive isomorphism of [Construction 2.1.108](#). \square

As a final elementary construction, we describe suspensions of 1-truss bundles, obtained by adding new initial and final elements to both the base poset and the total poset of the bundle.

CONSTRUCTION 2.1.110 (Suspension of posets). Let X be a poset. Its ‘suspension’ ΣX is the poset obtained from X by adjoining two elements \perp and \top , along with arrows $\perp \rightarrow x$ and $x \rightarrow \top$ for each $x \in X$. Note the suspension operation is functorial. \square

CONSTRUCTION 2.1.111 (Suspension of 1-truss bundles). Let $p : T \rightarrow B$ be a 1-truss bundle. The ‘suspension 1-truss bundle’ $\Sigma p : \Sigma T \rightarrow \Sigma B$ has base poset the suspension ΣB ; total poset $(\Sigma T, \trianglelefteq)$ the suspension $\Sigma(T, \trianglelefteq)$; frame order $(\Sigma T, \preceq)$ that relates elements if and only if they are already related in

(T, \preceq) ; and dimension map restricting on $T \hookrightarrow \Sigma T$ to the dimension map of the bundle p , while mapping the initial object $\perp \in \Sigma T$ to 1 and the final object $\top \in \Sigma T$ to 0. ┌

REMARK 2.1.112 (Suspension bundles via classifying functors). Given a 1-truss bundle $p : T \rightarrow B$, its suspension bundle $\Sigma p : \Sigma T \rightarrow \Sigma B$ has classifying functor $\chi_{\Sigma p} : \Sigma B \rightarrow \mathbf{TBord}^1$ given by the unique map that restricts on $B \hookrightarrow \Sigma B$ to the classifying functor χ_p , while mapping \perp to the initial truss \mathbb{T}_0 in \mathbf{TBord}^1 and mapping \top to the final truss \mathbb{T}_0 in \mathbf{TBord}^1 . (See Observation 2.1.54.) ┌

EXAMPLE 2.1.113 (Suspension 1-truss bundle). In Figure 2.25 we illustrate a 1-truss bundle $p : T \rightarrow B$ on the left, together with its suspension bundle $\Sigma p : \Sigma T \rightarrow \Sigma B$ on the right. ┌

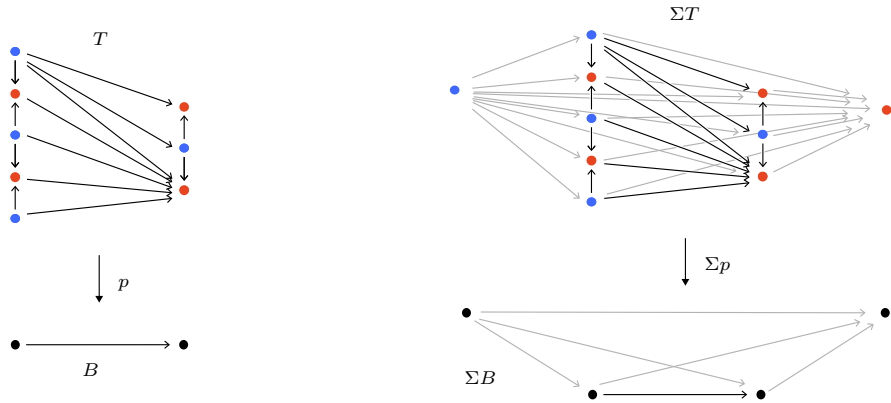

FIGURE 2.25. Suspension bundle of a 1-truss bundle.

2.2. Truss induction and labelings

As developed in the previous Section 2.1, 1-trusses provide a combinatorial model of stratified intervals, 1-truss bordisms provide a combinatorial model of stratified bundles of stratified intervals over the stratified interval, and 1-truss bundles provide a combinatorial model of stratified bundles of stratified intervals over more general stratified spaces. In the subsequent Section 2.3, we will double down, triple down, indeed n -tuple down on this combinatorialization of stratified topology, by considering 1-truss bundles over 1-truss bundles over 1-truss bundles and so on, as a completely combinatorial description of a quite general class of suitably framed stratified spaces. In order to have and maintain a grip on the structure of this tower of iterated 1-truss bundles, we will need a handle on the simplicial structure of 1-truss bundles themselves. The primary purpose of this Section 2.2 is to develop a pair of such handles, namely the existence of a total order on the collection of sections of a 1-truss bundle over a stratified simplex, and a related total order on the collection of top-dimensional simplices in the total poset of such a bundle; we will refer to the technique of exploiting those total orders (typically by showing that a property of a section or simplex implies a corresponding property of the successor section or simplex) as *truss induction*.

Recall for instance the 1-truss bundle over the 3-simplex from Figure 2.2. The total poset of this, or indeed any, 1-truss bundle over a simplex has the quite special feature that its top-dimensional simplices are all of dimension exactly one more than the dimension of the base; such top-dimensional simplices are called *spacers*. The combinatorial structure of such a bundle is controlled, patently, by its spacer simplices and how they are glued together along their facets. The spacers of this, or indeed any such, 1-truss bundle have the further distinctive feature that a facet simplex shared between two spacers necessarily projects isomorphically to the base; such simplices are called *sections*. The remarkable property of 1-truss bundles, completely peculiar among even specialized poset bundles over posets, though manifest from a certain geometric point of view, is that there is a canonical total order on the set of sections and spacers; we call this the *scaffold order*. That scaffold order, for the 1-truss bundle previously mentioned, is illustrated cryptically in Figure 2.26; this notation for the scaffold order will be deciphered in due course.

A stratified space can be understood as a space together with a map from the space to a fundamental poset, recording the distinct strata and their relationships; similarly, our eventual combinatorial description of stratified spaces will involve a combinatorial gadget, namely an iterated 1-truss bundle, together with a suitable map from the total poset of that gadget to a fundamental poset, now recording the combinatorial strata and their relationships. The basic instances of such suitable maps will be functors, which we call *labelings*, from the total poset of a 1-truss, or 1-truss bordism, or 1-truss

bundle, into a target poset or more generally target category. That labeled 1-truss bordisms have a well-defined composition, and therefore that there is a well-defined classifying category for labeled 1-truss bundles, is established by truss induction.

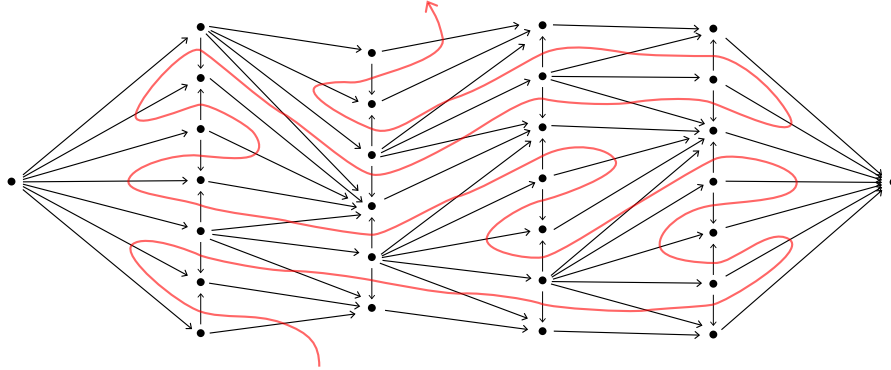

FIGURE 2.26. The scaffold order for a 1-truss bundle.

OUTLINE. In Section 2.2.1, we introduce section and spacer simplices of 1-truss bundles and classify them in terms of jump morphisms in the suspended bundle and fiber morphisms in the bundle, respectively. In Section 2.2.2, we define norms on the sections and spacers, and use them to construct a canonical linear order on both the set of sections and on the set of spacers, establishing the basis for our core technique of truss induction. Finally, in Section 2.2.3, we define labeled 1-trusses and their bordisms, whose composition is seen to be well-defined by truss induction, and use them to provide a classifying category for labeled 1-truss bundles.

2.2.1. Sections and spacers.

SYNOPSIS. We note the distinction between section simplices and spacer simplices in the total poset of a 1-truss bundle, as those simplices that project nondegenerately or degenerately to the base. We introduce jump morphisms and fiber morphisms of a 1-truss bundle, as those with regular domain and singular codomain and, respectively, projection being either a spine vector or a trivial vector of the base. We then describe the correspondence of section simplices and jump morphisms in the suspension bundle, and the correspondence of spacer simplices and fiber morphisms in the bundle itself.

2.2.1.1. The definition of sections and spacers. Recall that a k -simplex of a poset P , that is a map $[k] \rightarrow P$, is called ‘nondegenerate’ if the map is injective on objects, and is called ‘degenerate’ otherwise.

DEFINITION 2.2.1 (Sections of 1-truss bundles). For a 1-truss bundle $p : T \rightarrow B$, a k -**section** is a nondegenerate k -simplex $K : [k] \hookrightarrow (T, \leq)$ of the

total poset, such that the composite map $p \circ K : [k] \rightarrow B$ is a nondegenerate k -simplex in the base poset. $\quad _$

DEFINITION 2.2.2 (Spacers of 1-truss bundles). For a 1-truss bundle $p : T \rightarrow B$, a $(k+1)$ -**spacer** is a nondegenerate $(k+1)$ -simplex $K : [k+1] \hookrightarrow (T, \trianglelefteq)$ of the total poset, such that the composite map $p \circ K : [k+1] \rightarrow B$ is a degenerate simplex in the base poset. $\quad _$

TERMINOLOGY 2.2.3 (Simplices in 1-truss bundles). We sometimes refer to a nondegenerate simplex $[k] \hookrightarrow (T, \trianglelefteq)$ of the total poset of a 1-truss bundle $p : T \rightarrow B$, simply as ‘a simplex in the bundle’. $\quad _$

Note that every nondegenerate simplex in a 1-truss bundle is either a section or a spacer. Both k -sections and $(k+1)$ -spacers of 1-truss bundles always have images that are nondegenerate k -simplices of the base poset.

TERMINOLOGY 2.2.4 (Base projection of a simplex). Given an n -simplex $K : [n] \hookrightarrow T$ in a 1-truss bundle $p : T \rightarrow B$, its ‘base projection’ $\text{im}(p \circ K) : [m] \hookrightarrow B$ is the unique nondegenerate simplex of the base poset, whose image is the image of $p \circ K : [n] \rightarrow B$. $\quad _$

When considering a bundle over the k -simplex, we often concentrate on sections and spacers that project to the whole base.

TERMINOLOGY 2.2.5 (Base-surjective simplex). An n -simplex $K : [n] \hookrightarrow T$ in a 1-truss bundle $p : T \rightarrow [m]$ is called ‘base-surjective’ when its base projection $\text{im}(p \circ K)$ is the whole base poset $[m]$. $\quad _$

Of course, every section or spacer simplex is base-surjective in the pullback bundle over the base projection of that simplex; thus it usually suffices to think about, and illustrate, only the base-surjective situation.

EXAMPLE 2.2.6 (Sections and spacers in 1-truss bundles). In [Figure 2.27](#), we highlight 2-sections (on the left) and 3-spacers (on the right) of a 1-truss bundle over the 2-simplex. All these sections and spacers are base-surjective. $\quad _$

As the dimension of the base poset grows, it becomes less practical to draw the section and spacer simplices in a bundle. However, there is a quite convenient notation in any dimension, by restricting attention to the spine as follows.

NOTATION 2.2.7 (Sections and spacers via their spines). A 1-truss bundle $T \rightarrow [k]$ over a simplex is determined by the restriction of the bundle to the spine of the base simplex. Furthermore, any base-surjective section or spacer simplex in the bundle has its entire spine living over the spine of the base. We may and will therefore think of and refer to and depict section and spacer simplices purely in terms of their spines and the projections of those spines to the spine of the base.

An example of this method is illustrated in [Figure 2.28](#). There, on the left we show two sections (in blue and red) and two spacers (in green and

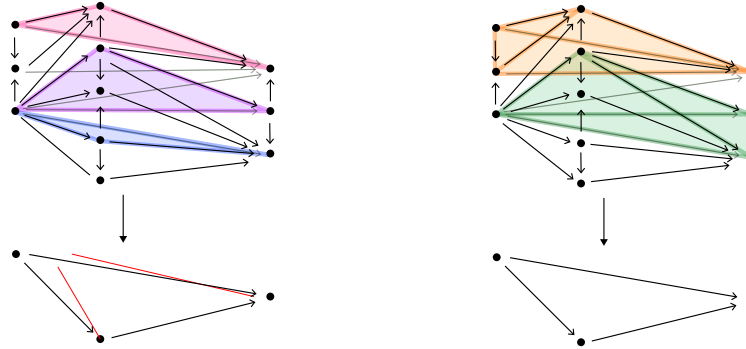

FIGURE 2.27. Sections and spacers in a 1-truss bundle.

yellow), all in a bundle over the 2-simplex. On the right, we depict the same sections and spacers just by highlighting their spines, over the spine of the base 2-simplex. └─

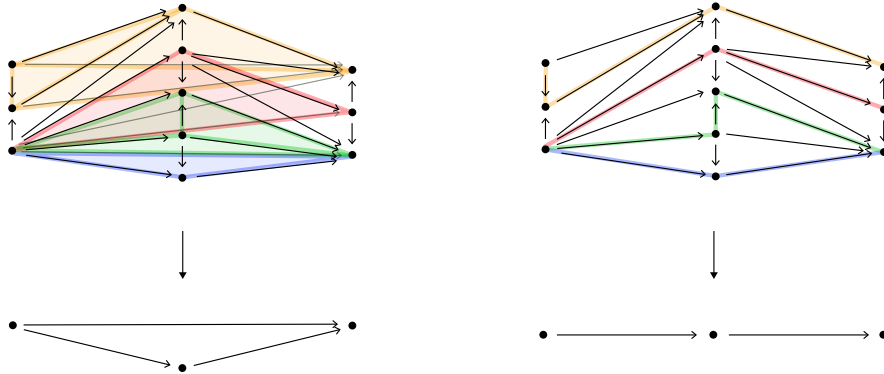

FIGURE 2.28. Spine notation for sections and spacers.

As noted, any section or spacer is base-surjective over its base projection; said another way, any simplex in a 1-truss bundle factors as a base-surjective simplex followed by a bundle inclusion, as follows.

REMARK 2.2.8 (Simplices factor through base-surjective simplices). Let $K : [n] \hookrightarrow T$ be a simplex in a 1-truss bundle $p : T \rightarrow B$, with base projection $F := \text{im}(p \circ K) : [m] \hookrightarrow B$. Then $K : [n] \hookrightarrow T$ factors as a composite of the base-surjective simplex $[n] \hookrightarrow F^*T$ and the bundle pullback inclusion $F^*T \hookrightarrow T$. This factorization provides a bijection between simplices in the bundle p whose base projection is $F : [m] \hookrightarrow B$ and base-surjective simplices in the pullback bundle $F^*p : F^*T \rightarrow [m]$. └─

On account of this factorization, for the remainder of Section 2.2.1 and for Section 2.2.2, we will work almost exclusively with bundles over simplices, and we will implicitly assume base-surjectivity.

CONVENTION 2.2.9 (Base-surjectivity by default). We will assume all sections and spacers are base-surjective unless otherwise noted. \square

NOTATION 2.2.10 (Set of sections and spacers). Given a 1-truss bundle $p : T \rightarrow [m]$, we denote its sets of sections and spacers as follows.

$$\begin{aligned}\Gamma_p &= \{\text{sections } K : [m] \hookrightarrow T \text{ of } p : T \rightarrow [m] \} \\ \Psi_p &= \{\text{spacers } L : [m+1] \hookrightarrow T \text{ of } p : T \rightarrow [m]\} \quad \square\end{aligned}$$

2.2.1.2. The spines of sections and spacers. 1-Truss bundles have such a specific combinatorial structure that both section simplices and spacer simplices (and thus all simplices) admit a manifest combinatorial classification in terms of when and how the spine of the simplex transitions from regular objects to singular objects.

REMARK 2.2.11 (1-truss bundle arrows weakly decrease dimension). Recall that in a 1-truss, the nontrivial arrows $a \rightarrow b$ strictly decrease dimension, i.e. $1 = \dim(a) > \dim(b) = 0$; that is, all such arrows have regular source and singular target. Furthermore, recall from [Observation 2.1.59](#) that in a 1-truss bordism, the relations $R(a, b)$ weakly decrease dimension, i.e. $\dim(a) \geq \dim(b)$. It follows (see [Terminology 2.1.72](#)) that all arrows in the associated poset of a 1-truss bordism, and thus all arrows in any 1-truss bundle, also weakly decrease dimension; in particular, all such arrows either have regular source and target, singular source and target, or regular source and singular target. \square

OBSERVATION 2.2.12 (Spines of simplices in 1-truss bundles). Consider a 1-truss bundle $p : T \rightarrow [m]$ over the m -simplex, and a k -simplex $K : [k] \hookrightarrow T$ in the bundle. The spine $\text{spine}[k] = (0 \rightarrow 1 \rightarrow \cdots \rightarrow k)$ maps to the spine $\text{spine } K([k]) = (K(0) \rightarrow K(1) \rightarrow \cdots \rightarrow K(k)) \subset T$. By the preceding remark, this spine has one of three forms:

- (1) All the objects $K(i)$ are regular.
- (2) All the objects $K(i)$ are singular.
- (3) There is a single ‘transition arrow’ $K(j-1) \rightarrow K(j)$ whose source is regular and whose target is singular; all objects $K(i \leq j-1)$ are regular, and all objects $K(i \geq j)$ are singular.

We refer to the lowest number j with $K(j)$ singular as the ‘transition index’. In the third case, that $K(j)$ is the target of the transition arrow; in the second case, the transition index is 0; in the first case, by convention we declare the transition index to be $k+1$.

In the first two cases, the simplex is necessarily a section, since any arrow in a fiber of the bundle would transition from regular to singular objects; we refer to such sections as ‘purely regular’ and ‘purely singular’, respectively. \square

NOTATION 2.2.13 (Base-fiber notation for 1-truss bundles). Given a 1-truss bundle $p : T \rightarrow B$, it is sometimes clarifying, if redundant, to denote

an object $a \in T$ by the pair $(p(a), a) \in B \times T$, that is, by an object of the base followed by an object in the corresponding fiber. —

REMARK 2.2.14 (Spines of sections). Applying Observation 2.2.12, a section simplex $K : [m] \hookrightarrow T$ in a 1-truss bundle $p : T \rightarrow [m]$ necessarily has, for some transition index $0 \leq j \leq m + 1$, the form

$$(0, a_0) \rightarrow (1, a_1) \rightarrow \cdots \rightarrow (j-1, a_{j-1}) \\ \rightarrow (j, b_j) \rightarrow (j+1, b_{j+1}) \rightarrow \cdots \rightarrow (m, b_m)$$

where each object a_i is regular and each object b_i is singular. Here if $j = m + 1$ then every object is regular, and if $j = 0$ then every object is singular; those are the first two cases of the previous observation. If the transition index j is strictly between 0 and $m + 1$, then the section has both regular and singular objects and is an instance of the third case of the observation. —

We can unify the three seemingly distinct section types (purely regular, purely singular, and mixed regular and singular) by shifting attention to the suspension of the 1-truss bundle, as follows.

NOTATION 2.2.15 (Suspending simplices). For convenience and compatibility with the usual representation of the standard m -simplex as $(0 \rightarrow 1 \rightarrow \cdots \rightarrow (m-1) \rightarrow m)$, we will identify the suspension $\Sigma[m]$ with the poset $(-1 \rightarrow 0 \rightarrow 1 \rightarrow \cdots \rightarrow (m-1) \rightarrow m \rightarrow m+1)$. —

CONSTRUCTION 2.2.16 (Suspending sections). Consider a section $K : [m] \hookrightarrow T$ in a 1-truss bundle $p : T \rightarrow [m]$. By Construction 2.1.110, the suspension $\Sigma K : \Sigma[m] \hookrightarrow \Sigma T$ has $\Sigma K(\perp) = \perp$ and $\Sigma K(\top) = \top$. Equivalently, using the conventions of Notation 2.2.13 and Notation 2.2.15, this may be written as $\Sigma K(-1) = (-1, r)$ and $\Sigma K(m+1) = (m+1, s)$, where r is the unique object of the initial 1-truss, and s is the unique object of the final 1-truss. Observe that ΣK is indeed a section of the bundle $\Sigma p : \Sigma T \rightarrow \Sigma[m]$, and the map $K \mapsto \Sigma K$ provides a bijective correspondence between sections in the bundle p and sections in the bundle Σp . (The inverse map is simply restricting sections $\Sigma[m] \hookrightarrow \Sigma T$ to the simplex $[m] \subset \Sigma[m]$.) —

Since the suspended section $\Sigma K : \Sigma[m] \hookrightarrow \Sigma T$ begins with a regular object and ends with a singular object, it is necessarily mixed, even if the section K was purely regular or purely singular; thus considering sections in terms of their suspension unifies the section types as desired.

More than the satisfying tidiness of all suspended sections having the same structure, the shift of perspective to the suspension allows a concise classification of sections of 1-truss bundles, as follows.

DEFINITION 2.2.17 (Jump morphisms). A **jump morphism** f in a 1-truss bundle $p : T \rightarrow [m]$ is an arrow in the total poset (T, \trianglelefteq) , whose domain $\text{dom}(f)$ is regular, whose codomain $\text{cod}(f)$ is singular, and whose base projection is a spine vector of the simplex $[m]$. —

CONSTRUCTION 2.2.18 (Correspondence of sections of a bundle and jump morphisms of the suspended bundle). Let $p : T \rightarrow [m]$ be a 1-truss bundle over the m -simplex. To each section $K : [m] \hookrightarrow T$ of the bundle, we can associate the transition arrow $\Sigma K(j-1) \rightarrow \Sigma K(j)$ of the suspended section $\Sigma K : \Sigma[m] \hookrightarrow \Sigma T$; note that j is the transition index of the section $K : [m] \hookrightarrow T$. This transition arrow $\Sigma K(j-1) \rightarrow \Sigma K(j)$ is a jump morphism of the suspended bundle $\Sigma p : \Sigma T \rightarrow \Sigma[m]$.

Conversely, consider a jump morphism f of the suspended bundle $\Sigma p : \Sigma T \rightarrow \Sigma[m]$, with base projection the spine vector $(j-1 \rightarrow j)$ in $\Sigma[m]$ (using Notation 2.2.15 for objects of $\Sigma[m]$); we can associate a section $K : [m] \hookrightarrow T$ of the bundle $p : T \rightarrow [m]$, defined by

- › for $i < j$, set $K(i) = \text{reg}_{\chi_p^{(i \rightarrow j-1)}}(\text{dom } f)$,
- › for $j \leq i$, set $K(i) = \text{sing}_{\chi_p^{(j \rightarrow i)}}(\text{cod } f)$.

(Recall that $\chi_p(k \rightarrow l)$ is the 1-truss bordism obtained by restricting the bundle to that arrow of the base; and reg^R and sing_R are the regular function and singular function of the bordism R .)

These associations are inverse, and provide a bijective correspondence between sections of a 1-truss bundle and jump morphisms of the suspension of that bundle. ┌

EXAMPLE 2.2.19 (Correspondence of sections and jump morphisms). In Figure 2.29 we illustrate a 1-truss bundle $p : T \rightarrow [2]$, together with its suspension $\Sigma p : \Sigma T \rightarrow \Sigma[2]$ (indicated in grey). We highlight the spines of four sections (using the spine-only method from Notation 2.2.7); for each of those sections, we mark the associated jump morphism in ΣT by a big dot of the same color. ┌

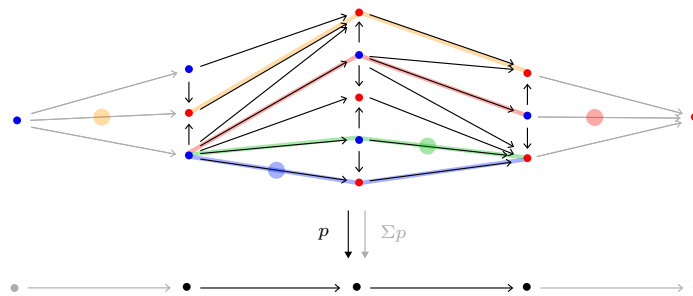

FIGURE 2.29. Sections and their associated jump morphisms.

We now proceed to the companion classification of spacer simplices in 1-truss bundles.

REMARK 2.2.20 (Spines of spacers). Again applying Observation 2.2.12, a spacer simplex $L : [m+1] \hookrightarrow T$ in a 1-truss bundle $p : T \rightarrow [m]$ necessarily

has, for some index $0 \leq j \leq m$, the form

$$(0, a_0) \rightarrow (1, a_1) \rightarrow \cdots \rightarrow (j, a_j) \rightarrow (j, b_j) \rightarrow (j + 1, b_{j+1}) \rightarrow \cdots \rightarrow (m, b_m)$$

where each object a_i is regular and each object b_i is singular. Note that in this case the transition arrow is $(j, a_j) \rightarrow (j, b_j)$ and the transition index is in fact $j + 1$, since $L(j + 1) = (j, b_j)$. In particular, unlike for sections, every spacer has at least one regular and at least one singular vertex. \square

DEFINITION 2.2.21 (Fiber morphisms). A **fiber morphism** f in a 1-truss bundle $p : T \rightarrow [m]$ is an arrow in the total poset (T, \trianglelefteq) , whose domain $\text{dom}(f)$ is regular, whose codomain $\text{cod}(f)$ is singular, and whose base projection is an identity arrow in the simplex $[m]$. \square

CONSTRUCTION 2.2.22 (Correspondence of spacers and fiber morphisms). Let $p : T \rightarrow [m]$ be a 1-truss bundle over the m -simplex $[m]$. To each spacer $L : [m + 1] \hookrightarrow T$ of the bundle, we can associate the transition arrow $(L(j) \rightarrow L(j + 1)) = ((j, a_j) \rightarrow (j, b_j))$; here $j + 1$ is the transition index of the spacer, and the transition arrow is a fiber morphism.

Conversely, for a fiber morphism f of the bundle $p : T \rightarrow [m]$ with base projection the identity on $j \in [m]$, we can associate a spacer $L : [m + 1] \hookrightarrow T$, defined by

- > for $i \leq j$, set $L(i) = \text{reg}^{\chi_p(i \rightarrow j)}(\text{dom } f)$,
- > for $j + 1 \leq i + 1$, set $L(i + 1) = \text{sing}_{\chi_p(j \rightarrow i)}(\text{cod } f)$.

These associations are inverse, and provide a bijective correspondence between spacers of a 1-truss bundle and fiber morphisms of that bundle. \square

EXAMPLE 2.2.23 (Correspondence of spacers and fiber morphisms). In Figure 2.30 we highlight the spines of four spacers in a 1-truss bundle $p : T \rightarrow [2]$; for each of those spacers, we mark the associated fiber morphism by a big dot of the same color.

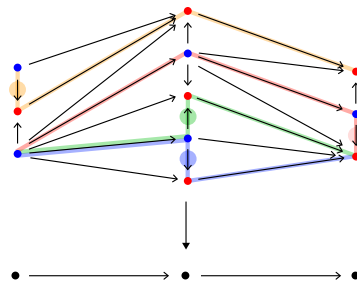

FIGURE 2.30. Spacers and their associated fiber morphisms.

2.2.2. The scaffold order. We now construct a canonical linear order on the set of sections, and a related canonical linear order on the set of spacers, in a 1-truss bundle over a simplex.

SYNOPSIS. We begin by illustrating the order on the set of sections as a directed path through the jump morphisms in the spine notation for the suspended bundle. We then define a numerical norm on sections, and prove that this norm induces a total order on the set of sections. Similarly, we illustrate the order on the set of spacers as a directed path through the fiber morphisms in the spine notation for the bundle. We then define a norm on spacers in terms of the norms of boundary sections, and prove that again this norm induces a total order on the set of spacers.

2.2.2.1. The case of sections. We construct a total order on the set of sections Γ_p of a 1-truss bundle $p : T \rightarrow [m]$ over the m -simplex; we will call this order the ‘scaffold order of sections’. Recall from [Construction 2.2.18](#) the correspondence of sections in a bundle and jump morphisms in the suspended bundle. The scaffold order on the sections is thus equivalent to an order on those jump morphisms, and that order on the jump morphisms has a convenient and illuminating visual representation, as shown in the next example. Moreover, the passage from each jump morphism to its successor in this order will form a core step in the subsequent formal construction of the scaffold order.

EXAMPLE 2.2.24 (Scaffold order). In [Figure 2.31](#) we illustrate *all* the sections in a 1-truss bundle over the 2-simplex (by highlighting the spines as before). We also mark the corresponding jump morphisms in the suspended bundle (by correspondingly colored dots). The scaffold order on these sections is depicted via an order on the jump morphisms; that order on the jump morphisms is indicated by the red directed path. Pragmatically, that path may be drawn (and is uniquely determined) by beginning with the jump morphism on the lower boundary, then crossing alternately and only through fiber morphisms and jump morphisms, until reaching a jump morphism on the upper boundary. —

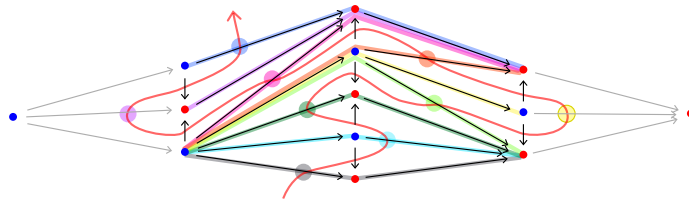

FIGURE 2.31. The scaffold order on sections.

We will construct the scaffold order on the sections Γ_p by defining a ‘scaffold norm’ $\Gamma_p \rightarrow \mathbb{N}$, and showing that the norm maps the set of sections

bijectionally to an interval of natural numbers; the scaffold order on sections is simply inherited from the standard order on \mathbb{N} .

To define the scaffold norm, it is convenient to use the notion of the frame height of an element in a 1-truss bundle, as follows. For a 1-truss bundle $p : T \rightarrow [m]$, let $\mathbf{hght} : (T, \preceq) \rightarrow (\mathbb{N}, \leq)$ be the unique map that sends every fiber $(p^{-1}(i), \preceq)$, $i \in [m]$, isomorphically to an initial segment of (\mathbb{N}, \leq) ; that is, the frame height $\mathbf{hght}(a)$ is $j - 1 \in \mathbb{N}$ when $a \in T$ is the j -th element in the total frame order of the fiber $p^{-1}(p(a))$.

DEFINITION 2.2.25 (Scaffold norm of sections). Consider a 1-truss bundle $p : T \rightarrow [m]$ and its set of sections Γ_p . The **scaffold norm** $\langle - \rangle$ is the function

$$\begin{aligned} \langle - \rangle : \Gamma_p &\rightarrow \mathbb{N} \\ K &\mapsto \sum_{i \in [m]} \mathbf{hght}(K(i)) \end{aligned}$$

taking a section to the sum of the frame heights of its elements. $\quad \text{—}$

OBSERVATION 2.2.26 (Suspension preserves scaffold norm). Recall the suspension operation on sections from Construction 2.2.16. Note that the suspension $\Sigma : \Gamma_p \rightarrow \Gamma_{\Sigma p}$ preserves the scaffold norm: $\langle K \rangle = \langle \Sigma K \rangle$ for $K \in \Gamma_p$. $\quad \text{—}$

In order to describe the image of the scaffold norm, we first construct the distinguished sections that minimize and maximize the norm.

TERMINOLOGY 2.2.27 (Bottom and top sections). A ‘bottom section’ or ‘top section’ of a 1-truss bundle is one that minimizes or maximizes, respectively, the scaffold norm. $\quad \text{—}$

CONSTRUCTION 2.2.28 (Bottom and top sections of a 1-truss bundle). Let $p : T \rightarrow [m]$ be a 1-truss bundle over the m -simplex $[m]$. We construct a bottom section $\mathbf{K}_p^- : [m] \hookrightarrow T$ and a top section $\mathbf{K}_p^+ : [m] \hookrightarrow T$, by setting the sections \mathbf{K}_p^\pm on $i \in [m]$ to be the lower and upper endpoints of the corresponding fiber: $\mathbf{K}_p^\pm(i) = \mathbf{end}_\pm(p^{-1}(i))$. That this defines valid sections follows from Observation 2.1.60 that 1-truss bordisms relate endpoints.

Note that the minimal value of the scaffold norm is $\langle \mathbf{K}_p^- \rangle = 0$ and the maximal value is $\langle \mathbf{K}_p^+ \rangle = \#T - \#[m]$ (where $\#T$ and $\#[m]$ are the number of elements in those posets). Denote these extremal values of the scaffold norm by $\mathbf{scaff}_\pm(p) := \langle \mathbf{K}_p^\pm \rangle$. Furthermore note that the sections \mathbf{K}_p^\pm are the unique sections realizing those minimal and maximal values. $\quad \text{—}$

The extremal values of the scaffold norm $\mathbf{scaff}_\pm(p)$ bound an interval of natural numbers, and that interval is precisely the image of the scaffold norm on sections.

LEMMA 2.2.29 (Scaffold order of sections). *For a 1-truss bundle $p : T \rightarrow [m]$ with sections Γ_p , the scaffold norm $\langle - \rangle : \Gamma_p \rightarrow \mathbb{N}$ is a bijection onto its image; that image is the set $[\mathbf{scaff}_-(p), \mathbf{scaff}_+(p)]$ of all natural numbers*

between the extremal values of the scaffold norm. The induced total order on the sections Γ_p is called the ‘scaffold order of sections’.

PROOF. The previous [Construction 2.2.28](#) provided unique bottom and top sections K_p^\pm with minimal and maximal scaffold norms $\mathsf{scaff}_\pm(p)$. We will now construct, for each non-top section $K \neq \mathsf{K}_p^+$, a successor section $\mathsf{s}(K)$ with scaffold norm $\langle \mathsf{s}(K) \rangle = \langle K \rangle + 1$, and conversely construct, for each non-bottom section $K \neq \mathsf{K}_p^-$, a predecessor section $\mathsf{p}(K)$ with scaffold norm $\langle \mathsf{p}(K) \rangle = \langle K \rangle - 1$. We will then observe that the successor and predecessor section constructions are mutually inverse; the lemma follows.

The successor section construction is briefer and more uniform in the case that all sections contain a jump morphism, i.e. when there are no purely regular or purely singular sections. Recall from [Construction 2.2.16](#) that there is an isomorphism $\Gamma_p \cong \Gamma_{\Sigma_p}$ of the sections of any bundle and the sections of its suspension, and by [Observation 2.2.26](#) this isomorphism commutes with the scaffold norm. It therefore suffices to construct the successor in suspended bundles; we will not assume the bundle p is, per se, a suspension but we will and may assume all its sections contain jump morphisms (as is true in any suspension).

Let $K \neq \mathsf{K}_p^+$ be a non-top section of the bundle $p : T \rightarrow [m]$, with jump morphism $K(j-1) \rightarrow K(j)$ in the total poset T . We prove that in the total poset T , there is *either* an arrow $K(j-1) + 1 \rightarrow K(j)$ *or* an arrow $K(j-1) \rightarrow K(j) + 1$. (There cannot be both such arrows due to bimonotonicity of 1-truss bordisms.) Since K is not the top section, there is a successor $K(l) + 1$ of $K(l)$ in the fiber over $l \in [m]$ for some index l .

Suppose there is a successor $K(l) + 1$ for an index $l \leq j-1$. In this case, since $K(l)$ is regular, the successor $K(l) + 1$ is singular. Consider the 1-truss bordism $R_l^{j-1} := p^{-1}(l \rightarrow j-1)$ and its singular function $\mathsf{sing}_{R_l^{j-1}} : \mathsf{sing}(p^{-1}(l)) \rightarrow \mathsf{sing}(p^{-1}(j-1))$. That singular function takes $K(l) + 1$ to some singular element $\mathsf{sing}_{R_l^{j-1}}(K(l) + 1) \in p^{-1}(j-1)$. Since $K(j-1)$ is regular, the frame order relation $K(l) \prec K(l) + 1$ and bimonotonicity of the bordism R_l^{j-1} imply the frame order relation $K(j-1) \prec \mathsf{sing}_{R_l^{j-1}}(K(l) + 1)$. In particular, there is a singular successor $K(j-1) + 1$ in the fiber $p^{-1}(j-1)$.

Suppose instead there is a successor $K(l) + 1$ for an index with $j \leq l$. Since $K(l)$ is singular, the successor $K(l) + 1$ is regular. An argument dual to the previous one, using the regular function $\mathsf{reg}^{R_j^l} : \mathsf{reg}(p^{-1}(j)) \leftarrow \mathsf{reg}(p^{-1}(l))$ of the 1-truss bordism $R_j^l := p^{-1}(j \rightarrow l)$, shows there is a regular successor $K(j) + 1$ in the fiber $p^{-1}(j)$.

If there is a successor $K(j-1) + 1$, but no successor $K(j) + 1$, then by bimonotonicity and [Observation 2.1.65](#) that bordisms fully relate elements, there must be an arrow $K(j-1) + 1 \rightarrow K(j)$. Similarly, if there is no successor $K(j-1) + 1$, but there is a successor $K(j) + 1$, then there must be an arrow $K(j-1) \rightarrow K(j) + 1$. If there is both a (singular) successor $K(j-1) + 1$ and a (regular) successor $K(j) + 1$, then (by bimonotonicity)

either there is an arrow $K(j - 1) + 1 \rightarrow K(j)$ (as desired) or there is an arrow $K(j - 1) + 1 \rightarrow s$ for some singular element $s \succ K(j)$; in the latter case, the structure of the singular determined 1-truss bordism in the proof of Lemma 2.1.63 implies that there is an arrow $K(j - 1) \rightarrow K(j) + 1$ (as desired).

We now construct the successor section $\mathfrak{s}(K)$ of K , distinguishing the two cases above, where $K(j - 1) + 1 \rightarrow K(j)$ or $K(j - 1) \rightarrow K(j) + 1$. These cases are illustrated in Figure 2.32; in each case the jump morphism $K(j - 1) \rightarrow K(j)$ is marked by a green dot, and the jump morphism of the successor section is marked by a purple dot. The successor is constructed in each case as follows.

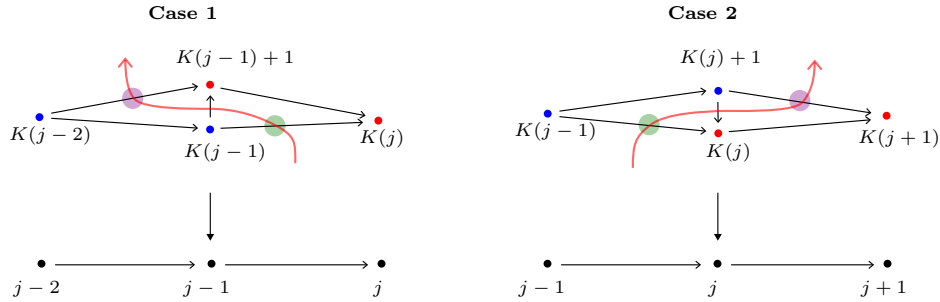

FIGURE 2.32. The construction of successor sections.

Case 1. When there is an arrow $K(j - 1) + 1 \rightarrow K(j)$, we construct the successor section $\mathfrak{s}(K)$ by setting $\mathfrak{s}(K)(j - 1) = K(j - 1) + 1$ and $\mathfrak{s}(K)(i) = K(i)$ if $i \neq j - 1$. We must have $j \geq 2$, as otherwise $\mathfrak{s}(K)$ would be a purely singular section, contradicting our assumption on the bundle p . Functoriality of the 1-truss bordism $p^{-1}(j - 2 \rightarrow j - 1)$ implies that there is an arrow $K(j - 2) \rightarrow K(j - 1) + 1$, ensuring that $\mathfrak{s}(K)$ is indeed a section.

Case 2. When there is an arrow $K(j - 1) \rightarrow K(j) + 1$, we construct the successor section $\mathfrak{s}(K)$ by setting $\mathfrak{s}(K)(j) = K(j) + 1$ and $\mathfrak{s}(K)(i) = K(i)$ if $i \neq j$. We must have $j \leq m - 1$, as otherwise $\mathfrak{s}(K)$ would be a purely regular section, contradicting our assumption on the bundle p . Functoriality of the 1-truss bordism $p^{-1}(j \rightarrow j + 1)$ then implies there is an arrow $K(j) + 1 \rightarrow K(j + 1)$, ensuring that $\mathfrak{s}(K)$ is indeed a section.

This completes the construction of successors.

The construction of predecessor sections $\mathfrak{p}(K)$, for non-bottom sections $K \neq K_p^-$, is given by the construction of successor sections for the bundle with opposite frame order; see Remark 2.1.82. (This opposite amounts to reading the total posets in Figure 2.32 upside down.) Observe that $\mathfrak{p}(\mathfrak{s}(K)) = K$ and similarly $\mathfrak{s}(\mathfrak{p}(K)) = K$, as required. \square

2.2.2.2. The case of spacers. Rather like the case of sections, we now construct a total order on the set of spacers Ψ_p in a 1-truss bundle $p : T \rightarrow [m]$ over the m -simplex; we call this order the ‘scaffold order of spacers’. Recall from [Construction 2.2.22](#) the correspondence of spacers and fiber morphisms in a bundle. The scaffold order on the spacers is therefore equivalent to an order on those fiber morphisms, and precisely as in the case of sections, that order on fiber morphisms has an efficient visual representation, as in the next example.

EXAMPLE 2.2.30 (Scaffold order on spacers). Recall from [Example 2.2.24](#) that the scaffold order of sections can be depicted by a directed path, namely the one that traverses the jump morphisms of the suspension while crossing a single fiber morphism between each two scaffold-order-adjacent jump morphisms. The order in which that path traverses the fiber morphisms is exactly the scaffold order on spacers. In [Figure 2.33](#) we illustrate all the spacers of the same 1-truss bundle as the previous example (by highlighting the spines), mark the corresponding fiber morphisms (by correspondingly colored dots), and depict the scaffold order again by the red directed path.

Earlier in [Figure 2.26](#), we illustrated a more complicated example of the scaffold order of both sections and spacers, for a 1-truss bundle over a 3-simplex, depicted again by a single directed path through the jump and fiber morphisms of the suspension. —

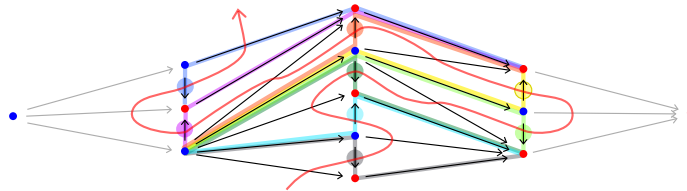

FIGURE 2.33. The scaffold order on spacers.

Any spacer of a bundle has exactly two facets that are sections, namely those facets obtained by omitting either the source or target of the fiber morphism. Those sections correspond to the two jump morphisms adjacent, along the illustrated directed path, to the fiber morphism of the spacer; the jump morphism preceding the fiber morphism will correspond to a ‘lower boundary section’ and the one subsequent to the fiber morphism will correspond to an ‘upper boundary section’, constructed as follows.

CONSTRUCTION 2.2.31 (Upper and lower boundary sections of spacers). Given a spacer $L : [m + 1] \hookrightarrow T$ of a 1-truss bundle $p : T \rightarrow [m]$, let $L(j) \rightarrow L(j + 1)$ be the fiber morphism of the spacer. When $L(j) \prec L(j + 1)$, the ‘lower boundary section’ $\partial_- L$ is the $(j + 1)$ th face $d_{j+1}L$ of the spacer L , and the ‘upper boundary section’ $\partial_+ L$ is the j th face $d_j L$ of the spacer L .

When by contrast $L(j+1) \prec L(j)$, then ∂_-L is the j th face d_jL , and ∂_+L is the $(j+1)$ th face $d_{j+1}L$. —

EXAMPLE 2.2.32 (Upper and lower boundary sections). In Figure 2.34 we highlight two spacers L and L' in a 1-truss bundle, together with their lower and upper boundary sections $\partial_\pm L$ and $\partial_\pm L'$. —

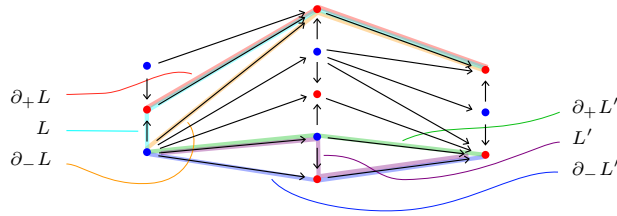

FIGURE 2.34. Upper and lower boundaries of spacers.

REMARK 2.2.33 (Upper boundaries succeed lower boundaries). The preceding construction ensures that the scaffold norms of the upper and lower boundaries of a spacer are related by $\langle \partial_+L \rangle = \langle \partial_-L \rangle + 1$; that is, the upper boundary ∂_+L is the successor of the lower boundary ∂_-L in the scaffold order (Γ_p, \preceq) of sections. —

As in the case of sections, we will construct the scaffold order on spacers Ψ_p in terms of a ‘scaffold norm’ $\Psi_p \rightarrow \mathbb{N} + \frac{1}{2}$.

DEFINITION 2.2.34 (Scaffold norm of spacers). Consider a 1-truss bundle $p : T \rightarrow [m]$ and its set of spacers Ψ_p . The **scaffold norm** $\langle - \rangle$ is the function

$$\begin{aligned} \langle - \rangle : \Psi_p &\rightarrow \mathbb{N} + \frac{1}{2} \\ L &\mapsto \frac{\langle \partial_-L \rangle + \langle \partial_+L \rangle}{2} \end{aligned}$$

taking a spacer to the average of the scaffold norms of its lower and upper boundaries. —

Analogously to the case of sections treated in Lemma 2.2.29, the scaffold norm of spacers will take the set of spacers bijectively to an interval of half-shifted natural numbers; the scaffold order on spacers is simply inherited from the standard order on that image.

LEMMA 2.2.35 (Scaffold order for spacers). *For a 1-truss bundle $p : T \rightarrow [m]$ with spacers Ψ_p , the scaffold norm $\langle - \rangle : \Psi_p \rightarrow \mathbb{N} + \frac{1}{2}$ is a bijection onto its image; that image is the set of all half integers between the extremal values scaff_- and scaff_+ of the scaffold norm of sections. The induced total order on the spacers Ψ_p is called the ‘scaffold order of spacers’.*

PROOF. Each spacer L in the bundle p is uniquely determined by its boundary sections $\partial_{\pm}L$, and those boundary sections are adjacent in the scaffold norm by Remark 2.2.33. The previous Lemma 2.2.29 thus implies that the scaffold norm of spacers $\langle - \rangle : \Psi_p \rightarrow \mathbb{N} + \frac{1}{2}$ is injective.

To see that this norm surjects onto the claimed image, consider a half integer h between the extremal section scaffold norms \mathbf{scaff}_- and \mathbf{scaff}_+ . The integers $h \pm \frac{1}{2}$ are necessarily, by Lemma 2.2.29, the scaffold norms of some section K and its successor $\mathbf{s}(K)$. Consider the cases of the construction of the successor in the proof of that Lemma. Observe that in case 1, the fiber morphism $K(j-1) \rightarrow \mathbf{s}(K)(j-1)$ determines (by Construction 2.2.22) a spacer L with $\partial_-L = K$ and $\partial_+L = \mathbf{s}(K)$. Similarly, in case 2, the fiber morphism $\mathbf{s}(K)(j) \rightarrow K(j)$ determines a spacer L with $\partial_-L = K$ and $\partial_+L = \mathbf{s}(K)$. Thus there is a spacer with the required scaffold norm. \square

We have seen that both the set of sections and the set of spacers of a 1-truss bundle $p : T \rightarrow [m]$ have total orders, and moreover that for each section there is a spacer that increments it to the next section. We can summarize and express this situation more categorically as follows.

CONSTRUCTION 2.2.36 (Fiber categories in 1-truss bundles). Let $p : T \rightarrow B$ be a 1-truss bundle, and consider a nondegenerate simplex $z : [m] \rightarrow B$. The ‘fiber category’ $\Phi_p(z)$ in the bundle p over the simplex z is the free category whose objects are sections $K \in \Gamma_{z^*p}$ (that is, sections over just that simplex, i.e. of the pullback bundle z^*p), and that has a generating morphism $L : \partial_-L \rightarrow \partial_+L$ for each spacer $L \in \Psi_{z^*p}$. —

CONSTRUCTION 2.2.37 (Transition functors of fiber categories). Let $p : T \rightarrow B$ be a 1-truss bundle. Consider a nondegenerate simplex $z : [m] \rightarrow B$ and let $y : [l] \rightarrow B$ be a face of the simplex z ; that is, there is an injection $[l] \hookrightarrow [m]$ so that the simplex y is the composite $[l] \rightarrow [m] \xrightarrow{z} B$. There is an inclusion of pullback bundles $y^*p \hookrightarrow z^*p$. A section of the bundle z^*p restricts to a section of the bundle y^*p , and a spacer of the bundle z^*p restricts either to a spacer or to a section of the bundle y^*p . This restriction provides a functor $-|_{y \subset z} : \Phi_p(z) \rightarrow \Phi_p(y)$, called the ‘fiber transition’ in the bundle p from the simplex z to the simplex y . —

OBSERVATION 2.2.38 (Structure of fiber categories and transition functors). For all 1-truss bundles $p : T \rightarrow B$, we have the following properties:

- (1) All fiber categories $\Phi_p(z)$ are total orders.
- (2) All transition functors $\Phi_p(z) \rightarrow \Phi_p(y)$ preserve endpoints.

The first property follows from Lemma 2.2.29 and Lemma 2.2.35, using the relation $\langle \partial_{\pm}L \rangle = \langle L \rangle \pm \frac{1}{2}$ between the scaffold norm of a spacer and its boundary sections. The second property follows from Construction 2.2.28 for bottom and top sections. Note that since the fiber categories are total orders, and a transition functor sends a generating morphism to either a generating

morphism or an identity, and transition functors preserve endpoints, it follows that all transition functors are surjective. \square

2.2.3. Labeled 1-trusses, bordisms, and bundles. As entertaining as 1-trusses and their bordisms and bundles themselves are, and as pretty as the inductive structure of simplices in 1-truss bundles itself may be, our eventual concern will be with stratified versions of towers of 1-truss bundles over 1-truss bundles over 1-truss bundles and so on. It will be both convenient and crucial to encode the relevant sort of stratifications and the iterated bundle structures in terms of labeled trusses. The labeling is an assignment, to each element and arrow of the truss (or truss bordism or bundle), of an object and morphism in a labeling category—that category could be a stratification poset or itself an inductively defined category of towers of truss bundles. Critically, the well-definedness of composition of labeled truss bordisms, and therefore the iterability of the labeled bordism and bundle constructions, is proven by truss induction.

SYNOPSIS. We define labeled 1-trusses and labeled 1-truss bordisms, and show that composition of labeled 1-truss bordisms is well defined; this provides a category of 1-trusses and their bordisms labeled in a given category, and therefore an iterable endofunctor on the category of categories. We then generalize these notions to labeled 1-truss bundles, and show that the category of labeled 1-trusses and their bordisms is a classifying category for labeled 1-truss bundles. Finally, we mention the labeled 1-truss bundle versions of the pullback, dualization, and suspension constructions.

2.2.3.1. The definition of labeled 1-trusses and their bordisms. A labeling of a 1-truss in a category is simply an assignment of objects and morphisms in the category to the elements and face arrows of the 1-truss. Since there are no composite face arrows, there is not even a nontrivial functoriality condition on the assignment.

DEFINITION 2.2.39 (Labeled 1-trusses). Given a category \mathbf{C} , a **\mathbf{C} -labeled 1-truss** T is a pair $(\underline{T}, \text{lbl}_T)$ consisting of a 1-truss \underline{T} and a functor $\text{lbl}_T : (\underline{T}, \triangleleft) \rightarrow \mathbf{C}$ from the face poset of the 1-truss to the category. \square

We refer to the 1-truss \underline{T} as the ‘underlying 1-truss’ of the labeled 1-truss, and to the functor lbl_T as the ‘labeling functor’. We can display the data of a labeled 1-truss compactly as

$$[0] \longleftarrow \underline{T} \xrightarrow{\text{lbl}_T} \mathbf{C}$$

The left arrow expresses the 1-truss pedantically as a 1-truss bundle over the trivial poset; the right arrow is the labeling functor.

A labeling of a 1-truss bordism in a category is similarly an assignment of objects and morphisms to the elements and arrows of the bordism, though now of course we insist that the assignment respect composition.

DEFINITION 2.2.40 (Labeled 1-truss bordisms). Given a category \mathbf{C} , a **C-labeled 1-truss bordism** R is a pair $(\underline{R}, \text{lbl}_R)$ consisting of a 1-truss bordism \underline{R} and a functor $\text{lbl}_R : (\underline{R}, \leq) \rightarrow \mathbf{C}$ from the total poset of the bordism to the category. \square

Here and later on, we freely elide the distinction between a 1-truss bordism, its associated total poset (as in Terminology 2.1.72), and also its total poset considered as a 1-truss bundle over the interval (as in Definition 2.1.74). We can display the data of a labeled 1-truss bordism compactly as

$$[1] \longleftarrow \underline{R} \xrightarrow{\text{lbl}_R} \mathbf{C}$$

The left arrow expresses the 1-truss bordism as a 1-truss bundle over the interval; the right arrow is the labeling functor. Needless to say, we consider this labeled 1-truss bordism as a morphism $R : R_0 \rightarrow R_1$ from a domain labeled 1-truss $R_0 := (\underline{R}|_0, (\text{lbl}_R)|_0)$ to a codomain labeled 1-truss $R_1 := (\underline{R}|_1, (\text{lbl}_R)|_1)$ (where $(\text{lbl}_R)|_i$ abbreviates the restriction of lbl_R to the subposet $\underline{R}|_i \subset \underline{R}$).

EXAMPLE 2.2.41 (A labeled 1-truss bordism). In Figure 2.35 we illustrate a 1-truss bordism labeled in the poset $[1] \times [1]$. The labeling is indicated by color matching the objects of the bordism and their corresponding images in the labeling poset; since this labeling category is a poset, the object map determines the labeling functor entirely. \square

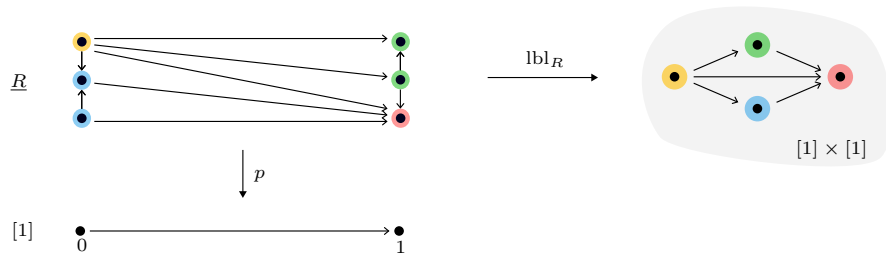

FIGURE 2.35. A labeled 1-truss bordism.

The natural next question is whether labeled 1-truss bordisms compose, that is, whether labeling functors on two composable 1-truss bordisms suitably induce a labeling functor on the composite 1-truss bordism.

DEFINITION 2.2.42 (Composition for labeled 1-truss bordisms). Given two \mathbf{C} -labeled 1-truss bordisms $R_{01} : T_0 \rightarrow T_1$ and $R_{12} : T_1 \rightarrow T_2$, the **composite labeled 1-truss bordism** $R_{02} = R_{12} \circ R_{01} : T_0 \rightarrow T_2$ has underlying 1-truss bordism \underline{R}_{02} being the composite $\underline{R}_{12} \circ \underline{R}_{01}$, and has labeling functor $\text{lbl}_{R_{02}} : \underline{R}_{02} \rightarrow \mathbf{C}$ specified by

$$\text{lbl}_{R_{02}}(x_0 \leq x_2) = \text{lbl}_{R_{12}}(x_1 \leq x_2) \circ \text{lbl}_{R_{01}}(x_0 \leq x_1)$$

whenever $x_0 \leq x_1$ and $x_1 \leq x_2$ are composable arrows of the total posets \underline{R}_{01} and \underline{R}_{12} , respectively. \square

LEMMA 2.2.43 (Composition of labeled 1-truss bordisms is well defined). *The labeling functor in the composition of labeled 1-truss bordisms is well defined.*

Before giving the proof, we give an example of how the composition of labeled functorial relations can fail to be well defined, and an example of the well-defined composition in the 1-truss bordism case.

EXAMPLE 2.2.44 (Composition of labeled functorial relations is not well defined). By contrast with the situation described in the previous lemma, composition of labeled functorial relations between 1-trusses, which one might try to specify as in Definition 2.2.42, is not well defined. We illustrate such a failure, where a label in the composite relation is overdetermined, in Figure 2.36. In the top left, there are two composable functorial relations \underline{R}_{01} and \underline{R}_{12} between 1-trusses. In the bottom left is their (trivial) composite functorial relation \underline{R}_{02} . The labeling functors $\text{lbl}_{R_{01}}$ and $\text{lbl}_{R_{12}}$ are indicated by color matching objects and their images, and color matching morphisms and their images. (Morphisms colored by an object color are labeled by the identity on that object.) The hypothetical composite labeling functor $\text{lbl}_{R_{02}}$ would take the morphism to both the red and the blue morphisms in the labeling category, and therefore does not exist. \square

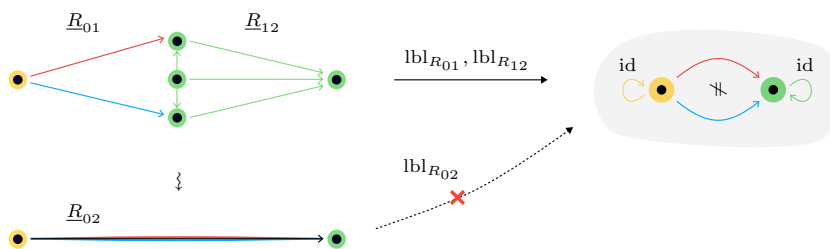

FIGURE 2.36. Failure of composition of labeled functorial relations.

EXAMPLE 2.2.45 (Composition of labeled 1-truss bordisms). In Figure 2.37, we illustrate two labeled 1-truss bordisms R_{01} and R_{12} along with their composite R_{02} . Notice that the underlying 1-truss bordisms here are those previously shown in Figure 2.23. The labeling category is a poset, so the labeling functors are determined by the color-coding of the objects.

The red arrows delineate a spacer simplex in the 1-truss bundle $\underline{W}_{012} \rightarrow [2]$ over the 2-simplex. The upper and lower sections of that spacer provide distinct factorizations of the red arrow in the composite. That spacer, along with the functoriality of the labeling of the two labeled 1-truss bordisms R_{01} and R_{12} , ensures (as explained in the proof below) that the composite red arrow has a well-specified label. The blue arrows similarly delineate three spacer simplices. The boundary sections of those spacers provide four distinct

factorizations of the blue arrow in the composite. Those spacers, chained together via truss induction (again as in the proof below), ensure that the composite blue arrow also has a well-specified label. \square

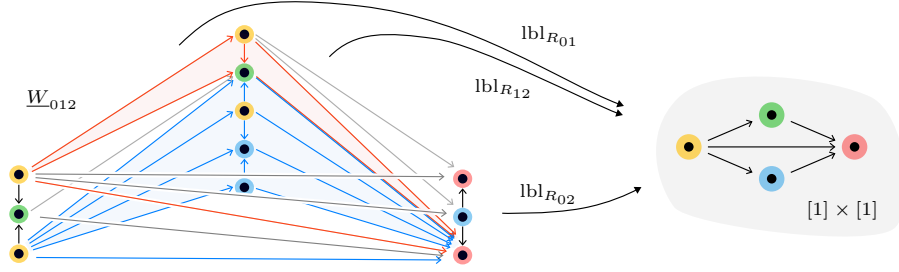

FIGURE 2.37. Composition of labeled 1-truss bordisms.

PROOF OF LEMMA 2.2.43. We have \mathbb{C} -labeled 1-truss bordisms $R_{01} : T_0 \rightarrow T_1$ and $R_{12} : T_1 \rightarrow T_2$; the composite $R_{02} : T_0 \rightarrow T_2$ has underlying 1-truss bordism $\underline{R}_{02} = \underline{R}_{12} \circ \underline{R}_{01}$, and labeling supposedly defined by $lbl_{R_{02}}(g_{12} \circ f_{01}) = lbl_{R_{12}}(g_{12}) \circ lbl_{R_{01}}(f_{01})$; we abbreviate that last composite by $lbl(g, f)$. Note that any arrow e of the composite bordism \underline{R}_{02} , by definition of the composite relation, has some decomposition $e = g \circ f$ and therefore some label assignment $lbl(g, f)$.

It suffices to check that whenever we have two distinct decompositions $g_{12} \circ f_{01} = g'_{12} \circ f'_{01}$, the putative labels correspond, that is,

$$lbl(g, f) := lbl_{R_{12}}(g_{12}) \circ lbl_{R_{01}}(f_{01}) = lbl_{R_{12}}(g'_{12}) \circ lbl_{R_{01}}(f'_{01}) =: lbl(g', f').$$

The bordisms \underline{R}_{01} and \underline{R}_{12} and their composite \underline{R}_{02} define a 1-truss bundle $\underline{W}_{012} \rightarrow [2]$, as in Example 2.1.95.

We proceed by truss induction in this bundle. The arrows f and g are the spine vectors of a section $K : [2] \rightarrow \underline{W}_{012}$, and the arrows f' and g' are the spine vectors of another section $K' : [2] \rightarrow \underline{W}_{012}$. Assume we have the scaffold order relation $K \preceq K'$ (the reverse case is the same); Lemma 2.2.29 ensures that there is a sequence of successor sections $K = K_0, K_1, \dots, K_k = K'$, that is with $\mathfrak{s}(K_i) = K_{i+1}$, starting with our section K and ending with our section K' . By induction, we may assume the sequence has length 1, that is $\mathfrak{s}(K) = K'$. Now by Lemma 2.2.35 there is a spacer $L : [3] \rightarrow \underline{W}_{012}$ with lower boundary $\partial_- L = K$ and upper boundary $\partial_+ L = K'$.

Note that the spine $L(2 \rightarrow 3) \circ L(1 \rightarrow 2) \circ L(0 \rightarrow 1)$ of that spacer L composes both to the spine $K(1 \rightarrow 2) \circ K(0 \rightarrow 1) = g \circ f$ of the section K , and to the spine $K'(1 \rightarrow 2) \circ K'(0 \rightarrow 1) = g' \circ f'$ of the section K' . Since the labeling lbl_{T_1} is the restriction of both $lbl_{R_{01}}$ and $lbl_{R_{12}}$ to the 1-truss fiber T_1 , functoriality of those labelings $lbl_{R_{01}}$ and $lbl_{R_{12}}$ implies

$$\begin{aligned} lbl(g, f) &= lbl_{R_{12}}(K(1 \rightarrow 2)) \circ lbl_{R_{01}}(K(0 \rightarrow 1)) \\ &= lbl_{R_{12}}(L(2 \rightarrow 3)) \circ lbl_{T_1}(L(1 \rightarrow 2)) \circ lbl_{R_{01}}(L(0 \rightarrow 1)) \end{aligned}$$

$$= \text{lbl}_{R_{12}}(K'(1 \rightarrow 2)) \circ \text{lbl}_{R_{01}}(K'(0 \rightarrow 1)) = \text{lbl}(g', f')$$

as required. \square

NOTATION 2.2.46 (Categories of labeled 1-trusses and their bordisms). Given a category \mathbf{C} , the ‘category of \mathbf{C} -labeled 1-trusses and their bordisms’, whose objects are \mathbf{C} -labeled 1-trusses and whose morphisms are \mathbf{C} -labeled 1-truss bordisms, will be denoted $\text{TBord}_{//\mathbf{C}}^1$. —

REMARK 2.2.47 (Unlabeled 1-trusses are trivially labeled). Of course, unlabeled 1-trusses and their bordisms may be considered as having ‘trivial’ labelings, that is labelings in the terminal category $*$. Indeed, the functor $\text{TBord}_{//\ast}^1 \rightarrow \text{TBord}^1$, taking an $*$ -labeled 1-truss T (respectively bordism R) to its underlying 1-truss \underline{T} (respectively bordism \underline{R}), is an isomorphism of categories. —

The construction of the category $\text{TBord}_{//\mathbf{C}}^1$ is functorial in the labeling category \mathbf{C} .

CONSTRUCTION 2.2.48 (Relabeling by a functor). Let $F : \mathbf{C} \rightarrow \mathbf{D}$ be a functor between categories. The associated ‘relabeling functor’ between categories of labeled 1-trusses and their bordisms

$$\text{TBord}_{//F}^1 : \text{TBord}_{//\mathbf{C}}^1 \rightarrow \text{TBord}_{//\mathbf{D}}^1$$

takes a \mathbf{C} -labeled 1-truss T to the \mathbf{D} -labeled 1-truss with underlying truss \underline{T} and labeling $F \circ \text{lbl}_T$, and similarly takes a \mathbf{C} -labeled bordism R to the \mathbf{D} -labeled bordism with underlying bordism \underline{R} and labeling $F \circ \text{lbl}_R$. —

TERMINOLOGY 2.2.49 (Label-forgetting functor). Note that relabeling by the terminal functor $\mathbf{C} \rightarrow *$ provides a ‘label-forgetting’ functor

$$(_): \text{TBord}_{//\mathbf{C}}^1 \rightarrow \text{TBord}_{//\ast}^1 \cong \text{TBord}^1$$

which simply removes the labeling data. —

The alchemical observation is that the functoriality of the construction of labeled 1-trusses and their bordisms provides, as follows, an endofunctor on the category of categories, which is therefore *iterable*—and iterate it we will.

DEFINITION 2.2.50 (The labeled 1-truss bordism functor). The **labeled 1-truss bordism functor** is the endofunctor

$$\text{TBord}_{//_}^1 : \text{Cat} \rightarrow \text{Cat}$$

that takes a category \mathbf{C} to the category $\text{TBord}_{//\mathbf{C}}^1$ of \mathbf{C} -labeled 1-trusses and their bordisms, and takes a functor $F : \mathbf{C} \rightarrow \mathbf{D}$ to the relabeling functor $\text{TBord}_{//F}^1 : \text{TBord}_{//\mathbf{C}}^1 \rightarrow \text{TBord}_{//\mathbf{D}}^1$. —

We may recast the notion of labeled 1-truss bordisms in more abstract categorical terms, as we did for unlabeled 1-truss bordisms at the end of

Section 2.1.2.1. (Readers without a categorical bent may skip ahead to Section 2.2.3.2 without consequence.)

Recall that 1-truss bordisms are in particular functorial relations between preorders, and functorial relations are the same concept as boolean profunctors. A labeling of a 1-truss bordism is of course a functor from the total face poset to a (not-necessarily posetal) category. To express the category of labeled bordisms in a concise categorical fashion, we need a context subsuming both boolean profunctors and ordinary functors; such a context is provided by the bicategory $\mathbb{P}\text{rof}$ of categories, profunctors, and natural transformations.

We transport 1-trusses and their bordisms into categories and profunctors as follows.

CONSTRUCTION 2.2.51 (Bordisms as profunctors). The ‘bordism-as-profunctor pseudofunctor’

$$\iota : \mathbf{TBord}^1 \rightsquigarrow \mathbb{P}\text{rof}$$

from the category of 1-trusses and their bordisms to the bicategory of profunctors, takes a 1-truss T to the face poset category (T, \triangleleft) , and takes a 1-truss bordism R to its boolean profunctor, considered as a profunctor via the inclusion $\mathbf{Bool} \hookrightarrow \mathbf{Set}$. —

Note well that, as elaborated in the following remark, it is not the case that there is a sensible pseudofunctor $\mathbf{BoolProf} \rightsquigarrow \mathbb{P}\text{rof}$, and so in particular not the case that the pseudofunctor $\mathbf{TBord}^1 \rightsquigarrow \mathbb{P}\text{rof}$ arises as a composite $\mathbf{TBord}^1 \rightarrow \mathbf{BoolProf} \rightsquigarrow \mathbb{P}\text{rof}$.

REMARK 2.2.52 (1-Truss bordisms are special among boolean profunctors). Boolean profunctors compose as their underlying relations, while ordinary profunctors compose by coends (see [Lor21, §5]). Given a boolean profunctor R , by considering booleans as sets in the usual way, there is an associated profunctor $[R]$. For general boolean profunctors $R : X \rightarrow Y$ and $S : Y \rightarrow Z$ between general preorders X , Y , and Z , it need *not* be the case that the profunctor of the composite is the composite of the profunctors: $[S \circ R] \not\cong [S] \circ [R]$. In particular the associated profunctor operation $[-]$ is not a pseudofunctor.

However, when the preorders X , Y , and Z are in fact 1-trusses, and the boolean profunctors R and S are in fact 1-truss bordisms, there is a unique isomorphism between the profunctor of the composite and the composite of the profunctors; that isomorphism emerges by explicitly evaluating the colimit defining the profunctor composite and following the arguments in the proof of Lemma 2.2.43. The resulting isomorphism $\iota(S \circ R) \cong \iota(S) \circ \iota(R)$ is the pseudofunctoriality data of the bordisms-as-profunctors pseudofunctor. —

We have now resituated 1-trusses (and their bordisms) as having associated categories (and profunctors) in the bicategory $\mathbb{P}\text{rof}$, and of course potential labeling categories also reside as objects in that bicategory. Our categorical recasting of $\mathbf{TBord}_{//\mathcal{C}}^1$ will be a direct instantiation of the following abstract generalization of comma categories. (Recall that for a functor

$F : A \rightarrow B$ and an object $b \in B$, the comma category F/b has as objects pairs $(a \in A, f : F(a) \rightarrow b)$ and morphisms $(a, f) \rightarrow (a', f')$ are those morphisms $(a \rightarrow a')$ in A such that $F(a \rightarrow a')$ commutes with the given morphisms f and f' in B .)

CONSTRUCTION 2.2.53 (Vertical comma categories). Given a normal pseudofunctor $H : \mathbb{T} \rightsquigarrow \mathbb{P}\text{rof}$ from a category \mathbb{T} into the bicategory $\mathbb{P}\text{rof}$, and a category $\mathbb{C} \in \mathbb{P}\text{rof}$, the ‘vertical comma category’ $H//_{\mathbb{C}}$ is defined as follows: the objects are pairs $(t \in \mathbb{T}, F : H(t) \rightarrow \mathbb{C})$, consisting of an object t of the category \mathbb{T} , and a *functor* (not profunctor) F from the image category $H(t)$ to the category \mathbb{C} ; 1-morphisms $(t, F) \rightarrow (t', F')$ are pairs $(r : t \rightarrow t', \alpha : H(r) \Rightarrow \text{Hom}_{\mathbb{C}}(F-, F'-))$, consisting of a morphism r in the category \mathbb{T} , and a natural transformation of profunctors from the image profunctor $H(r)$ to the Hom profunctor $\text{Hom}_{\mathbb{C}}(F-, F'-)$. —

The terminology ‘vertical comma category’ arises from implicitly considering $\mathbb{P}\text{rof}$ not as a bicategory but as a double category with vertical functors and horizontal profunctors; the arrow of the comma category is specified to be vertical, thus a functor rather than a profunctor. Our choice of notation $H//_{\mathbb{C}}$, and therefore obviously our choice of notation $\text{TBord}^1//_{\mathbb{C}}$ for labeled bordisms, is similarly inspired by the implicit sense that it is a sort of comma or slice category in a double categorical context.

OBSERVATION 2.2.54 (Categorical reformulation of labeled 1-trusses and their bordisms). For a category \mathbb{C} , the category of \mathbb{C} -labeled 1-trusses and their bordisms, as in Notation 2.2.46, is equivalent to the vertical comma category of the bordism-as-profunctor pseudofunctor over the category \mathbb{C} :

$$\text{TBord}^1//_{\mathbb{C}} \simeq (\text{TBord}^1 \rightsquigarrow \mathbb{P}\text{rof})//_{\mathbb{C}} \quad \text{—}$$

There is one last yet more abstract construction of the category of labeled 1-trusses and their bordisms, using the profunctorial collage of Remark 2.1.101, as follows.

TERMINOLOGY 2.2.55 (The tautological 1-truss bundle). The pseudofunctor $\iota : \text{TBord}^1 \rightsquigarrow \mathbb{P}\text{rof}$ from Construction 2.2.51, conceived of as a collagable classifying pseudofunctor, has a corresponding exponentiable functor $\rho : \text{ETBord}^1 \rightarrow \text{TBord}^1$; that functor is called the ‘tautological 1-truss bundle’—indeed the fiber over each object $T \in \text{TBord}^1$ is the 1-truss T as a category. (Note that this bundle is a categorical 1-truss bundle in the sense of Remark 2.1.85.) —

OBSERVATION 2.2.56 (Labeled 1-trusses and their bordisms via the tautological bundle). We will see a bit later that the category $\text{TBord}^1//_{\mathbb{C}}$ of \mathbb{C} -labeled 1-trusses and their bordisms is a classifying category for \mathbb{C} -labeled 1-truss bundles. Such a classifying category should be the universal category living over the classifying category TBord^1 (for unlabeled 1-trusses and their bordisms), that has a functor from its total 1-truss category (obtained as the pullback of the tautological 1-truss bundle) to the labeling category \mathbb{C} .

That universal category can be obtained as follows. Because the tautological 1-truss bundle ρ is exponentiable, the functor $\text{Cat}/_{\text{TBord}^1} \rightarrow \text{Cat}/_{\text{ETBord}^1}$ that takes the pullback of the tautological bundle (along a classifying functor $F : \mathbf{B} \rightarrow \text{TBord}^1$) has a right adjoint (cf. [Str01]); and certainly the forgetful functor $\text{Cat}/_{\text{ETBord}^1} \rightarrow \text{Cat}$ has a right adjoint. The composite of those adjoints provides a functor $\text{Cat} \rightarrow \text{Cat}/_{\text{TBord}^1}$ that sends a category \mathbf{C} to the category $\text{TBord}^1_{//\mathbf{C}}$ of \mathbf{C} -labeled 1-trusses and their bordisms (with its forgetful functor to TBord^1). \square

2.2.3.2. The definition of labeled 1-truss bundles. Given the notion of labeled 1-truss bordisms from the previous section, and considering 1-truss bordisms as 1-truss bundles over the interval, we of course have the generalization to labeled 1-truss bundles over other posets, by asking for a labeling functor from the total poset, as follows.

DEFINITION 2.2.57 (Labeled 1-truss bundles). Given a poset B and a category \mathbf{C} , a **\mathbf{C} -labeled 1-truss bundle** p over B is a pair $(\underline{p}, \text{lbl}_p)$ consisting of a 1-truss bundle $\underline{p} : T \rightarrow B$, and a functor $\text{lbl}_p : (T, \triangleleft) \rightarrow \mathbf{C}$ from the total poset of the bundle to the category. \square

We refer to the bundle \underline{p} as the ‘underlying 1-truss bundle’, and to the functor lbl_p as the ‘labeling functor’. We can display the data of a labeled 1-truss bundle $p \equiv (\underline{p}, \text{lbl}_p)$ compactly as

$$B \xleftarrow{\underline{p}} T \xrightarrow{\text{lbl}_p} \mathbf{C}$$

EXAMPLE 2.2.58 (1-Truss bundle labeled in a poset). In Figure 2.38 we illustrate a 1-truss bundle labeled in the poset [2]. In the previous Figure 2.35 of a $([1] \times [1])$ -labeled 1-truss bordism, we indicated the labeling by the object mapping; though that would suffice here, given the additional complexity of this bundle, it is easier to parse the labeling by its behavior on morphisms. We therefore indicate the labeling functor also by color matching the morphisms of the total poset of the bundle and their corresponding images in the labeling poset. \square

EXAMPLE 2.2.59 (1-Truss bundle labeled in a monoid). Though all of our labeled 1-truss bordism and bundle examples so far were labeled in a poset, and certainly that will be a case of core concern, still the labeling category may perfectly well be non-posetal. In Figure 2.39, we illustrate a 1-truss bundle $\underline{p} : T \rightarrow \bar{\mathbb{T}}_1$ (the one previously pictured in Example 2.1.94), together with a labeling $\text{lbl}_p : T \rightarrow \mathbf{BF}$ in the ‘opposite flip flop monoid’ \mathbb{F} . That monoid \mathbb{F} has two non-identity, idempotent elements r and s with composition $r \circ s = s$ and $s \circ r = r$. We indicate the elements r and s by colored arrows and, as in the previous example, record the labeling functor by color matching morphisms with their images.

As it happens, this monoid is the bordism endomorphism monoid of the closed 1-truss with three singular elements: $\mathbb{F} = \text{End}_{\text{TBord}^1}(\bar{\mathbb{T}}_2)$. As such,

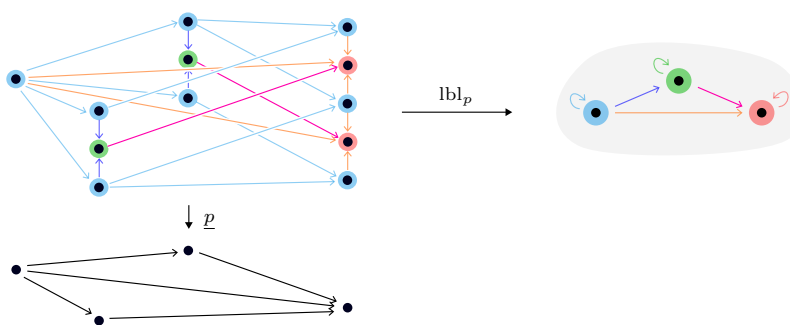

FIGURE 2.38. A 1-truss bundle labeled in a poset.

this labeling may be considered as associating the closed 5-element truss to each element of the total poset T , and associating a 1-truss bordism to each arrow of that total poset. Altogether this provides a new 1-truss bundle $q : S \rightarrow T$ with base now the previous total poset T ; the reader may endeavor to picture the total poset S of that bundle—we will return to such bundles in due course. —

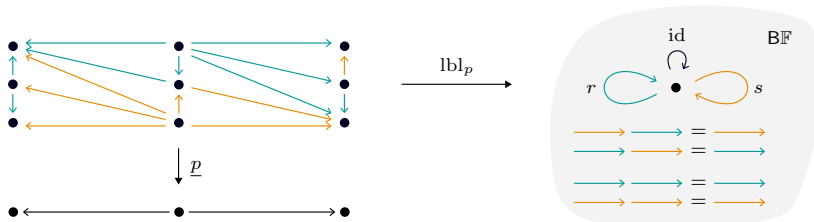

FIGURE 2.39. A 1-truss bundle labeled in a monoid.

Recall that maps of 1-truss bundles are simply maps of the total diposets; the labeled analog is immediate, as follows.

DEFINITION 2.2.60 (Maps of labeled 1-truss bundles). For categories \mathbf{C} and \mathbf{D} , let p be a \mathbf{C} -labeled 1-truss bundle, and let q be a \mathbf{D} -labeled 1-truss bundle. A **map of labeled 1-truss bundles** $F : p \rightarrow q$ is a pair $(\underline{F}, \text{lbl}_F)$ consisting of a 1-truss bundle map $\underline{F} : \underline{p} \rightarrow \underline{q}$, and a functor $\text{lbl}_F : \mathbf{C} \rightarrow \mathbf{D}$ such that $\text{lbl}_F \circ \text{lbl}_p = \text{lbl}_q \circ \underline{F}$. —

As in previous cases, we refer to the 1-truss bundle map \underline{F} as the ‘underlying bundle map’; we call the functor lbl_F the ‘label category functor’ or sometimes the ‘relabeling functor’. We can display the data of a map $F \equiv (\underline{F}, \text{lbl}_F)$ of labeled 1-truss bundles compactly as

$$\begin{array}{ccccc}
 B & \xleftarrow{\underline{p}} & T & \xrightarrow{\text{lbl}_p} & C \\
 \downarrow & & \downarrow \underline{F} & & \downarrow \text{lbl}_F \\
 C & \xleftarrow{\underline{q}} & S & \xrightarrow{\text{lbl}_q} & D
 \end{array}$$

TERMINOLOGY 2.2.61 (Label-preserving and base-preserving maps). A labeled 1-truss bundle map $F \equiv (\underline{F}, \text{lbl}_F)$ is called ‘label preserving’ if the label category functor lbl_F is the identity $\text{id}_{\mathcal{C}}$ of the label category, and is called ‘base preserving’ if the underlying bundle map \underline{F} covers the identity id_B of the base poset. —

TERMINOLOGY 2.2.62 (Singular, regular, and balanced labeled bundle maps). A labeled 1-truss bundle map $F \equiv (\underline{F}, \text{lbl}_F)$ is ‘singular’, ‘regular’, or ‘balanced’ if its underlying 1-truss bundle map \underline{F} is, respectively. —

Composition of underlying maps of bundles, along with composition of the label category functors, provides the following category.

NOTATION 2.2.63 (The category of labeled 1-truss bundles). The category of labeled 1-truss bundles and their maps is denoted LbTrsBun_1 . —

REMARK 2.2.64 (Unlabeled 1-truss bundles are trivially labeled). As in the case of bordisms in Remark 2.2.47, all 1-truss bundles have a unique labeling in the terminal category. This labeling provides a fully faithful functor $\text{TrsBun}_1 \hookrightarrow \text{LbTrsBun}_1$ from the category of 1-truss bundles into the category of labeled 1-truss bundles. —

TERMINOLOGY 2.2.65 (Restriction of labeled 1-truss bundles). Given a \mathcal{C} -labeled 1-truss bundle $p \equiv (\underline{p} : T \rightarrow B, \text{lbl}_p : T \rightarrow \mathcal{C})$ and a subposet $A \hookrightarrow B$, the ‘restriction’ of the labeled bundle to the subposet is the \mathcal{C} -labeled 1-truss bundle $p|_A \equiv (\underline{p}|_A : T|_A \rightarrow A, (\text{lbl}_p)|_A : T|_A \rightarrow \mathcal{C})$. —

REMARK 2.2.66 (Balanced label- and base-preserving isomorphisms are unique). Recall from Convention 2.1.20 and Remark 2.1.21 that balanced isomorphisms of 1-trusses preserve all structural data and are unique when they exist. Similarly, balanced label- and base-preserving 1-truss bundle isomorphisms preserve all structural data (face order, frame order, dimension map, base projection, labeling functor) and are unique when they exist. There is therefore never any need to distinguish between distinct but balanced label- and base-preservingly isomorphic labeled 1-truss bundles. —

2.2.3.3. Classification and totalization for labeled 1-truss bundles.

Previously in Observation 2.1.100 we saw that 1-truss bundles were classified by functors into the category TBord^1 of 1-trusses and their bordisms. As we detail presently, the labeled situation is entirely analogous: \mathcal{C} -labeled 1-truss bundles are classified by functors into the category $\text{TBord}_{//\mathcal{C}}^1$ of \mathcal{C} -labeled 1-trusses and their bordisms.

CONSTRUCTION 2.2.67 (Classifying functors of labeled 1-truss bundles). We describe a map

$$p \equiv (\underline{p} : T \rightarrow B, \text{lbl}_p : T \rightarrow \mathcal{C}) \quad \mapsto \quad (\chi_p : B \rightarrow \text{TBord}_{//\mathcal{C}}^1)$$

that takes a \mathcal{C} -labeled 1-truss bundle p over a poset B to an associated **classifying functor** $\chi_p : B \rightarrow \text{TBord}_{//\mathcal{C}}^1$.

We construct χ_p on elements and arrows of the poset B , as follows. For each element $x : [0] \hookrightarrow B$, the classifying element $\chi_p(x) \in \mathbf{TBord}_{//C}^1$ is the C -labeled 1-truss $p|_x$, and for each non-identity arrow $f : [1] \hookrightarrow B$, the classifying morphism $\chi_p(f)$ of $\mathbf{TBord}_{//C}^1$ is the C -labeled 1-truss bordism $p|_f$.

That this construction indeed provides a functor χ_p follows directly from the [Definition 2.2.57](#) of labeled bundles and the [Definition 2.2.42](#) of labeled bordism composition. —

CONSTRUCTION 2.2.68 (Total labeled 1-truss bundles of classifying functors). We describe a map

$$(F : B \rightarrow \mathbf{TBord}_{//C}^1) \mapsto \pi_F \equiv (\pi_{\underline{F}} : \text{Tot}(\underline{F}) \rightarrow B, \text{lbl}_F : \text{Tot}(\underline{F}) \rightarrow C)$$

that takes a functor $F : B \rightarrow \mathbf{TBord}_{//C}^1$ from a poset B to the category of C -labeled 1-trusses and their bordisms to an associated **total labeled 1-truss bundle** π_F .

We construct the labeled 1-truss bundle π_F as follows.

- ▷ The underlying 1-truss bundle $\pi_{\underline{F}} : \text{Tot}(\underline{F}) \rightarrow B$ is the total bundle of the composite \underline{F} of the functor F with the label-forgetting functor $(\text{—}) : \mathbf{TBord}_{//C}^1 \rightarrow \mathbf{TBord}^1$ (see [Terminology 2.2.49](#)).
- ▷ The labeling functor $\text{lbl}_F : \text{Tot}(\underline{F}) \rightarrow C$ is given on fibers over elements $x \in B$ as the labeling functor $\text{lbl}_{F(x)} : \underline{F}(x) \rightarrow C$ of the labeled 1-truss $F(x) \in \mathbf{TBord}_{//C}^1$, and on fibers over non-identity arrows $f : [1] \rightarrow B$ as the labeling functor $\text{lbl}_{F(f)} : \underline{F}(f) \rightarrow C$ of the labeled 1-truss bordism $F(f)$. —

EXAMPLE 2.2.69 (Classification for a labeled 1-truss bundle). Recall from [Example 2.2.59](#) the labeled 1-truss bundle $p \equiv (\underline{p} : T \rightarrow \overline{\mathbb{T}}_1, \text{lbl}_p : T \rightarrow \mathbf{BF})$ with labeling in the monoid \mathbf{BF} described there. In [Figure 2.40](#), on the left is that same labeled 1-truss bundle (with the labeling encoded by the colors of the arrows according to the convention for the monoid established in [Figure 2.39](#) and recapitulated in this figure); on the right is the associated classifying functor $\chi_p : \overline{\mathbb{T}}_1 \rightarrow \mathbf{TBord}_{//\mathbf{BF}}^1$. (The inverse association taking that functor $F : \overline{\mathbb{T}}_1 \rightarrow \mathbf{TBord}_{//\mathbf{BF}}^1$ to its total labeled bundle π_F is also indicated.) In the classifying category $\mathbf{TBord}_{//\mathbf{BF}}^1$, we only indicatively depict four of the eighteen objects and only four of the many morphisms among those objects; the two morphisms actually hit by this classifying functor are colored accordingly, along with their preimages in the base poset. —

As in the unlabeled case, this correspondence, between labeled 1-truss bundles and functors into the category of labeled 1-trusses and their bordisms, is functorial, with respect to a notion of bordism of labeled 1-truss bundles.

DEFINITION 2.2.70 (Bordisms of labeled 1-truss bundles and their composition). Given C -labeled 1-truss bundles p and q over a poset B , a **C -labeled 1-truss bundle bordism** $u : p \rightarrow q$ is a C -labeled 1-truss bundle u over $B \times [1]$ such that $u|_{B \times \{0\}} = p$ and $u|_{B \times \{1\}} = q$.

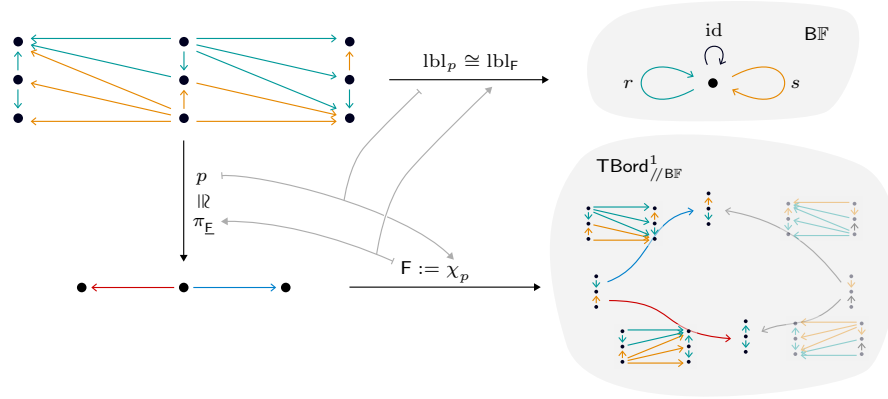

FIGURE 2.40. A labeled 1-truss bundle and its classifying functor.

The **composition** of two such labeled bordisms $u : p \rightarrow q$ and $v : q \rightarrow r$ is the labeled bordism $v \circ u : p \rightarrow r$ whose restriction $(v \circ u)|_{\{x\} \times [1]}$ is the composite labeled bordism $v|_{\{x\} \times [1]} \circ u|_{\{x\} \times [1]}$, for all elements $x \in B$. \square

NOTATION 2.2.71 (Categories of labeled 1-truss bundles and their bordisms). For a fixed base poset B and category \mathcal{C} , the ‘category of \mathcal{C} -labeled 1-truss bundles and their bordisms’, whose objects are \mathcal{C} -labeled 1-truss bundles over B and whose morphisms are \mathcal{C} -labeled 1-truss bundle bordisms, will be denoted $\text{TBord}(B) //_{\mathcal{C}}$. \square

REMARK 2.2.72 (Labeled 1-truss bundle isobordism need not be unique). By contrast with Observation 2.1.98, when there is an invertible labeled 1-truss bundle bordism (i.e. a ‘labeled bundle isobordism’), that bordism need not be unique, for the simple reason that the labeling category may have non-trivial automorphisms. \square

There is a category of functors from a base poset B to the category $\text{TBord}^1 //_{\mathcal{C}}$ of labeled 1-trusses and their bordisms, whose morphisms are natural transformations of functors; note that a natural transformation $\mathbf{N} : \mathbf{F} \Rightarrow \mathbf{G}$ between functors $\mathbf{F} : B \rightarrow \text{TBord}^1 //_{\mathcal{C}}$ and $\mathbf{G} : B \rightarrow \text{TBord}^1 //_{\mathcal{C}}$ is simply itself a functor $\mathbf{N} : B \times [1] \rightarrow \text{TBord}^1 //_{\mathcal{C}}$. Equipped with the category of labeled 1-truss bundles and their bordisms, and with the category of classifying functors, we can describe the functorial correspondence, as follows.

OBSERVATION 2.2.73 (Classification and totalization functors for labeled 1-truss bundles). Given a poset B and a category \mathcal{C} , there is an equivalence of categories

$$\chi_- : \text{TBord}(B) //_{\mathcal{C}} \rightleftarrows \text{Fun}(B, \text{TBord}^1 //_{\mathcal{C}}) : \pi_-$$

specified as follows.

The ‘classification functor’ χ_- takes a \mathbf{C} -labeled 1-truss bundle p to its classifying functor $\chi_p : B \rightarrow \mathbf{TBord}_{//\mathbf{C}}^1$, and a \mathbf{C} -labeled 1-truss bundle bordism $u : p \rightarrow q$ (by definition a labeled 1-truss bundle over $B \times [1]$) to its classifying functor $\chi_u : B \times [1] \rightarrow \mathbf{TBord}_{//\mathbf{C}}^1$ viewed as a natural transformation $\chi_u : \chi_p \Rightarrow \chi_q$.

The ‘totalization functor’ π_- takes a functor $F : B \rightarrow \mathbf{TBord}_{//\mathbf{C}}^1$ to its total \mathbf{C} -labeled 1-truss bundle π_F , and a natural transformation $\mathbf{N} : B \times [1] \rightarrow \mathbf{TBord}_{//\mathbf{C}}^1$ to its total labeled 1-truss bundle $\pi_{\mathbf{N}}$. $\quad \text{—}$

REMARK 2.2.74 (Classifying categorical labeled 1-truss bundles). Recall from Remark 2.1.85 the notion of a categorical 1-truss bundle $\mathbf{T} \rightarrow \mathbf{B}$ over a base category \mathbf{B} . A ‘categorical \mathbf{C} -labeled 1-truss bundle’ is simply a categorical 1-truss bundle $\underline{p} : \mathbf{T} \rightarrow \mathbf{B}$ together with a labeling functor $\text{lbl}_p : \mathbf{T} \rightarrow \mathbf{C}$. Remark 2.1.102 noted that \mathbf{TBord}^1 provides, in fact, a classifying category for categorical, not just posetal, 1-truss bundles. Similarly, the above classification and totalization constructions carry over to the categorical case, showing that $\mathbf{TBord}_{//\mathbf{C}}^1$ is a classifying category for categorical, not just posetal, \mathbf{C} -labeled 1-truss bundles. $\quad \text{—}$

After having developed the machinery of truss induction in generality in Section 2.2.2, notice that we have so far used truss induction only over the 2-simplex (namely, in the proof of Lemma 2.2.43). The full power of truss induction comes to bear when we allow for truss bundles labeled in an ∞ -category \mathcal{C} . For a 1-category \mathbf{C} , we had a 1-category $\mathbf{TBord}_{//\mathbf{C}}^1$ as a classifying category for \mathbf{C} -labeled 1-truss bundles; for an ∞ -category \mathcal{C} , we can define an analogous ∞ -category $\mathcal{TBord}_{//\mathcal{C}}^1$ as a classifying category for \mathcal{C} -labeled 1-truss bundles, as follows. (Note though that we will not use ∞ -categorical labels, and the next remark can be safely skipped.)

REMARK 2.2.75 (Quasicategories of labeled 1-trusses and their bordisms). Let \mathcal{C} be a quasicategory, i.e. a simplicial set that has inner horn fillers [BV73, Joy02]. There is a ‘quasicategory of \mathcal{C} -labeled 1-trusses and their bordisms’, denoted $\mathcal{TBord}_{//\mathcal{C}}^1$. The k -simplices of this quasicategory are the pairs $(\underline{S}, \text{lbl}_S)$ consisting of a 1-truss bundle $\underline{S} \rightarrow [k]$ over the k -simplex, and a functor of quasicategories $\text{lbl}_S : \underline{S} \rightarrow \mathcal{C}$.

The proof of Lemma 2.2.43, that composition of \mathbf{C} -labeled 1-truss bordisms, and therefore the category $\mathbf{TBord}_{//\mathbf{C}}^1$, is well defined, only used truss induction over the 2-simplex. That the simplicial set $\mathcal{TBord}_{//\mathcal{C}}^1$ is itself a quasicategory (i.e. has the ‘composition’ of inner horn fillers) follows, roughly as in that proof, but using truss induction over general k -simplices. $\quad \text{—}$

2.2.3.4. Pullback, dualization, and suspension of labeled 1-truss bundles. The pullback, dualization, and suspension constructions carry over from the unlabeled to the labeled case, as follows.

CONSTRUCTION 2.2.76 (Pullbacks of labeled 1-truss bundles). Given a \mathbf{C} -labeled 1-truss bundle $p \equiv (\underline{p} : T \rightarrow B, \text{lbl}_p : T \rightarrow \mathbf{C})$ over a poset B , and a poset map $G : A \rightarrow B$, the pullback of the bundle (along the map G) is the \mathbf{C} -labeled 1-truss bundle $G^*p \equiv (\underline{G^*p}, \text{lbl}_{G^*p})$, whose underlying 1-truss bundle $\underline{G^*p}$ is the pullback $G^*\underline{p} : G^*T \rightarrow A$, and whose labeling functor lbl_{G^*p} is the composite $\text{lbl}_p \circ \text{Tot}G : G^*T \rightarrow \mathbf{C}$. (Recall from Construction 2.1.103 the unlabeled pullback $G^*\underline{p} : G^*T \rightarrow A$ and its total poset map $\text{Tot}G : G^*T \rightarrow T$.) \square

We can display the labeled pullback bundle $G^*p \equiv (\underline{G^*p} : G^*T \rightarrow A, \text{lbl}_{G^*p} : G^*T \rightarrow \mathbf{C}) = (G^*\underline{p}, \text{lbl}_p \circ \text{Tot}G)$ as

$$\begin{array}{ccccc}
 A & \xleftarrow{G^*\underline{p}} & G^*T & \xrightarrow{\text{lbl}_p \circ \text{Tot}G} & \mathbf{C} \\
 \downarrow G & & \downarrow \text{Tot}G & \searrow & \uparrow \\
 B & \xleftarrow{\underline{p}} & T & \xrightarrow{\text{lbl}_p} & \mathbf{C}
 \end{array}$$

Of course, when the poset map $G : A \hookrightarrow B$ is a subposet, the pullback specializes to the restriction of labeled 1-truss bundles.

REMARK 2.2.77 (Pullback of labeled bundles via classifying functors). As in the unlabeled case, the labeled pullback bundle may be expressed in terms of classifying functors. Given a labeled 1-truss bundle p over a poset B and a poset map $G : A \rightarrow B$, the classifying functor $\chi_{G^*p} : A \rightarrow \mathbf{TBord}_{//\mathbf{C}}^1$ of the pullback is simply the composite $\chi_p \circ G$ of the poset map G with the classifying functor $\chi_p : B \rightarrow \mathbf{TBord}_{//\mathbf{C}}^1$ of the initial labeled bundle. \square

Fiberwise dualization provides a dualization of labeled 1-truss bundles, as follows.

CONSTRUCTION 2.2.78 (Dualization of labeled 1-truss bundles and their maps). Given a \mathbf{C} -labeled 1-truss bundle $p \equiv (\underline{p}, \text{lbl}_p)$, its dual is the \mathbf{C}^{op} -labeled 1-truss bundle $p^\dagger \equiv (\underline{p}^\dagger, \text{lbl}_{p^\dagger}) = ((\underline{p})^\dagger, (\text{lbl}_p)^{\text{op}})$, whose underlying 1-truss bundle is the dual of the underlying 1-truss bundle of p (i.e. has opposite face order and dimension map, see Construction 2.1.107), and whose labeling is the opposite of the labeling of p .

Given a labeled 1-truss bundle map $F : p \rightarrow q$ (consisting of an underlying map $\underline{F} : \underline{p} \rightarrow \underline{q}$ and a relabeling functor $\text{lbl}_F : \mathbf{C} \rightarrow \mathbf{D}$), its dual is the labeled bundle map $F^\dagger : p^\dagger \rightarrow q^\dagger$ with dual underlying 1-truss bundle map $\underline{F}^\dagger := (\underline{F})^\dagger : (\underline{p})^\dagger \rightarrow (\underline{q})^\dagger$ (i.e. the same map of sets as the map \underline{F} itself, see Construction 2.1.107), and opposite relabeling functor $\text{lbl}_{F^\dagger} := (\text{lbl}_F)^{\text{op}} : \mathbf{C}^{\text{op}} \rightarrow \mathbf{D}^{\text{op}}$.

We therefore have a covariant involutive functor of labeled 1-truss bundles:

$$\dagger : \mathbf{LblTrsBun}_1 \cong \mathbf{LblTrsBun}_1.$$

Note that this functor preserves neither the base nor the labeling category. \square

CONSTRUCTION 2.2.79 (Dualization of labeled 1-truss bundles and their bordisms). For a \mathbf{C} -labeled 1-truss bundle bordism $u : p \rightarrow q$, given by a \mathbf{C} -labeled 1-truss bundle $u \equiv (\underline{u} : U \rightarrow B \times [1], \text{lbl}_u : U \rightarrow \mathbf{C})$, its dual is the labeled bundle bordism $u^\dagger : q^\dagger \rightarrow p^\dagger$ given by the dual labeled bundle $u^\dagger \equiv (\underline{u}^\dagger, \text{lbl}_{u^\dagger}) = ((\underline{u})^\dagger : U^\dagger \rightarrow B^{\text{op}} \times [1], (\text{lbl}_u)^{\text{op}} : U^\dagger \rightarrow \mathbf{C}^{\text{op}})$.

Dualization of bordisms is thus contravariant, giving an involutive isomorphism:

$$\dagger : \text{TBord}(B)_{//\mathbf{C}} \cong (\text{TBord}(B^{\text{op}})_{//\mathbf{C}^{\text{op}}})^{\text{op}}.$$

When the labeling category is trivial, this specializes to the dualization of unlabeled bundles and their bordisms from [Construction 2.1.108](#). When instead the base is a point, this specializes to an involutive isomorphism on labeled 1-trusses and their bordisms:

$$\dagger : \text{TBord}_{//\mathbf{C}}^1 \cong (\text{TBord}_{//\mathbf{C}^{\text{op}}}^1)^{\text{op}}. \quad \text{—}$$

REMARK 2.2.80 (Dual labeled bundles via classifying functors). The dualization of labeled bundles may be reexpressed using classifying functors as follows. Given a labeled 1-truss bundle p , with classifying functor $\chi_p : B \rightarrow \text{TBord}_{//\mathbf{C}}^1$, its dual labeled bundle p^\dagger has classifying functor

$$(\chi_{p^\dagger} : B^{\text{op}} \rightarrow \text{TBord}_{//\mathbf{C}^{\text{op}}}^1) = (B \xrightarrow{\chi_p} \text{TBord}_{//\mathbf{C}}^1 \xrightarrow{\dagger} (\text{TBord}_{//\mathbf{C}^{\text{op}}}^1)^{\text{op}})^{\text{op}}.$$

This association of classifying functors $\chi_p \mapsto (\dagger \circ \chi_p)^{\text{op}}$ is functorial and reproduces the involutive isomorphism of the previous [Construction 2.2.79](#). —

Finally, straightforwardly, we have the labeled version of the suspension of 1-truss bundles from [Construction 2.1.111](#).

REMARK 2.2.81 (Suspension of labeled 1-truss bundles). Assume that the category \mathbf{C} has both initial and terminal objects. The suspension Σp of a \mathbf{C} -labeled 1-truss bundle p has, of course, underlying bundle $\underline{\Sigma p}$ being the suspension $\underline{\Sigma p} : \Sigma T \rightarrow \Sigma B$ of the underlying 1-truss bundle $\underline{p} : T \rightarrow B$; the labeling functor $\text{lbl}_{\Sigma p} : \Sigma T \rightarrow \mathbf{C}$ is equal to the labeling functor lbl_p on the equator $T \subset \Sigma T$ and sends the initial and terminal objects of ΣT to the initial and terminal objects of the labeling category \mathbf{C} . —

2.3. n -Trusses, bordisms, bundles, and blocks

1-Trusses have provided a robust combinatorial model of framed stratified 1-dimensional spaces. 1-Truss bundles encode families of such spaces and so appear to model certain multi-dimensional stratified spaces; however, the stratified topology of the total spaces of those families is critically constrained by the nature of the stratifications of the bases. To obtain a faithful, universal combinatorial model of framed stratified n -dimensional spaces we must, as promised, iterate the notion of 1-truss bundles. An n -truss is a 1-truss bundle over a 1-truss bundle over a 1-truss bundle, and so forth, over, in the end, a 1-truss. An example of an n -truss is illustrated on the left in Figure 2.41; the base 1-truss poset T_1 has a single (red) singular element, the 2-truss poset T_2 fibers over the 1-truss poset with the singular elements forming an X pattern, and the 3-truss poset T_3 fibers over the 2-truss poset with the singular elements forming a braid pattern that resolves the singular crossing of the 2-truss X. On the right of that figure are corresponding geometric stratifications of the open 1-, 2-, and 3-cubes—corresponding for instance in the sense that the fundamental posets of those stratified cubes are the adjacent truss posets. Needless to say this juxtaposition of n -trusses and stratified spaces is meant to suggestively preview the fact that the theory of n -trusses will indeed, as imagined, provide a resilient combinatorial model of framed stratified spaces of any dimension.

Now, any model of such stratified spaces must account for stratified families thereof, and so there is an attendant basic notion of n -truss bordism, which specifies a family of n -trusses over the combinatorial stratified 1-simplex, and furthermore a notion of n -truss bundle, which encodes a family of n -trusses over a more general stratified poset. Recall that the composition of 1-truss bordism functorial relations between 1-truss posets provided a transparent means of composing 1-truss bordisms. By contrast, even the existence of a composition of n -truss bordisms is neither geometrically nor combinatorially evident. Constructing such a composition will rely critically on the method of truss induction developed in the previous Section 2.2. In practice, that construction will occur in mutually inductive tandem with establishing that n -truss bundles are classified by functors into a *recursive category of n -trusses*, defined as 1-trusses labeled in 1-trusses labeled in 1-trusses labeled in, and so forth, labeled in, finally, 1-trusses.

OUTLINE. In Section 2.3.1, we introduce n -trusses as towers of 1-truss bundles, and n -truss bordisms as such towers over a combinatorial 1-simplex; we also define a recursive category of n -trusses in terms of 1-trusses labeled in 1-trusses labeled in 1-trusses and so on iteratively. In Section 2.3.2, we define general n -truss bundles as towers now over arbitrary posets, and prove that n -truss bundles are classified by functors into the recursive category of n -trusses. Finally, in Section 2.3.3, we describe n -truss blocks, the component combinatorial shapes from which all n -trusses are built, and block sets, the presheaves on the category of such blocks.

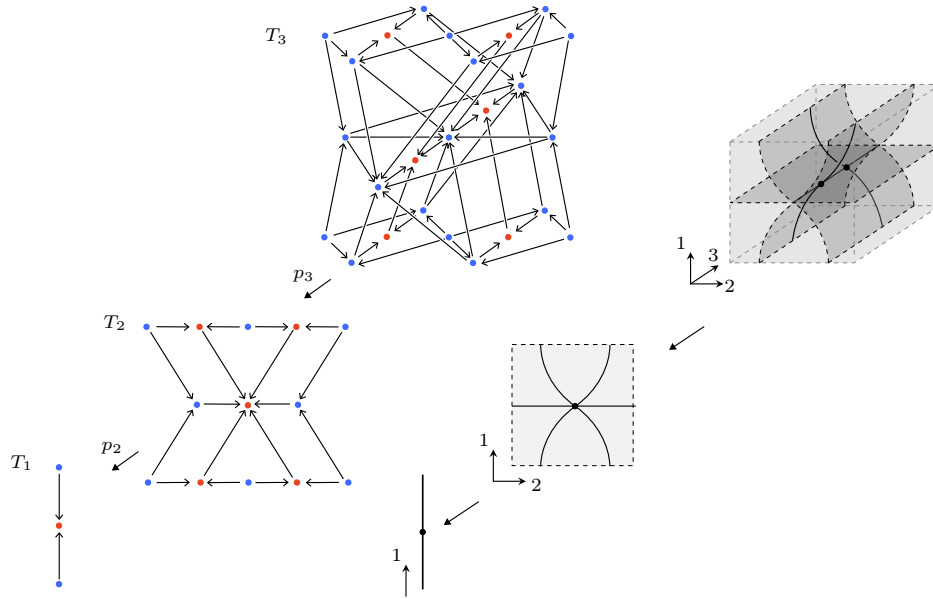

FIGURE 2.41. A 3-truss and its corresponding stratifications.

2.3.1. *n*-Trusses and their bordisms.

SYNOPSIS. We define *n*-trusses as towers of 1-truss bundles, with the base poset of each bundle being the total poset of the previous bundle. We similarly introduce *n*-truss bordisms as towers of 1-truss bundles over the combinatorial 1-simplex, describe the succession of functorial relations determined by the stages of such towers, and define the composition of *n*-truss bordisms in terms of the composites of those functorial relations; this will provide a category of *n*-trusses and their bordisms. We then apply the *n*-fold iteration of the labeled 1-truss bordism functor to obtain an alternative, recursively-defined version of the category of *n*-trusses and their bordisms.

2.3.1.1. *n*-Trusses as towers of 1-truss bundles. A 1-truss considered just with its face order is, of course, a poset; we have a notion of 1-truss bundle over any poset. A 2-truss is then simply a 1-truss bundle over the 1-truss face poset. The face order of that 1-truss bundle provides the total poset of the 2-truss. A 3-truss is then a 1-truss bundle over the 2-truss total poset. And so on, as follows.

DEFINITION 2.3.1 (*n*-Trusses). An ***n*-truss** is a sequence of 1-truss bundles

$$T_n \xrightarrow{p_n} T_{n-1} \xrightarrow{p_{n-1}} \dots \xrightarrow{p_2} T_1 \xrightarrow{p_1} T_0 = [0]$$

in which the base poset of each bundle p_i is the total poset of the subsequent bundle p_{i-1} . □

NOTATION 2.3.2 (*n*-Trusses). We typically abbreviate the sequence of bundles $\{T_i \xrightarrow{p_i} T_{i-1}\}$ by an indicative letter, referring to the whole *n*-truss

simply as T . (We will often refer to the sequence informally as a ‘tower of bundles’ and to its k th element T_k as the ‘ k -stage’ of the tower.) We call the face order poset (T_n, \trianglelefteq) of the first bundle the ‘total poset’ of the n -truss; we almost always let the face order relation be implicit, denoting the total poset simply T_n . Correspondingly, plain order symbols such as \leq and \geq on truss posets refer to the face order. —

TERMINOLOGY 2.3.3 (Open and closed n -trusses). We call an n -truss T ‘open’, respectively ‘closed’, when all its constituent 1-truss bundles $p_i : T_i \rightarrow T_{i-1}$ are open, respectively closed. —

EXAMPLE 2.3.4 (A 2-truss). In Figure 2.42, on the left we illustrate a 2-truss T . The first bundle $p_1 : T_1 \rightarrow T_0$ has base poset $T_0 = [0]$ and so its total poset is simply a 1-truss T_1 . The total poset T_2 of the second bundle $p_2 : T_2 \rightarrow T_1$, with its 1-truss fibers and bordism transitions between them, evidently has a 2-dimensional character.

On the right of that figure, we illustrate a tower of stratified bundles of stratified intervals, whose fundamental poset tower is the given 2-truss face poset tower. That this juxtaposition comes from a faithful correspondence between truss towers and towers of appropriately framed suitably stratified bundles, will be of crucial concern, and is established rather later on. —

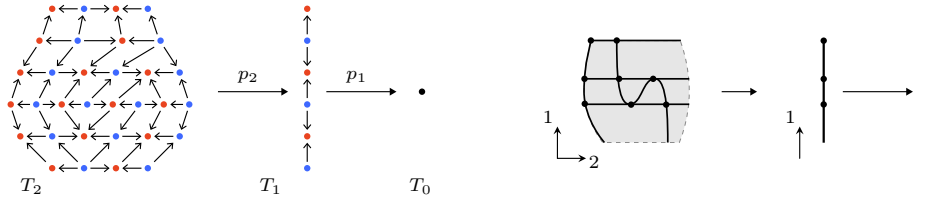

FIGURE 2.42. A 2-truss and corresponding stratifications.

EXAMPLE 2.3.5 (An open 3-truss). Earlier in Figure 2.41, on the left we illustrated an open 3-truss T . As before and as becomes especially prudent in 3-dimensional examples, we only depicted generating arrows of the truss face posets; all other arrows are composites of the given ones. On the right of the figure, we illustrated a corresponding tower of stratifications, of the open 3-cube, 2-cube, and 1-cube; the fundamental poset tower is the given 3-truss face poset tower. Notice that each of these cube stratifications is a refinement of the pullback of the previous cube stratification; the structure of that refinement reflects the geometric relationships among the singular elements in the correlative truss poset. —

Recall that a labeled 1-truss bundle is a 1-truss bundle with a labeling functor from the total poset of the bundle. Similarly, a labeled n -truss is just an n -truss with a labeling functor from its total poset. That labeling will, most immediately, provide a means of encoding yet further truss bundles

over that total poset, and, later on and most practically, provide a means of encoding global stratification structures on the total poset.

DEFINITION 2.3.6 (Labeled *n*-trusses). Given a category **C**, a **C**-labeled *n*-truss *T* is a pair $(\underline{T}, \text{lbl}_T)$ consisting of an *n*-truss $\underline{T} = (T_n \rightarrow T_{n-1} \rightarrow \dots \rightarrow T_0 = [0])$ and a functor $\text{lbl}_T : T_n \rightarrow \mathbf{C}$ from the total poset of the *n*-truss to the category. —

We refer as before to the *n*-truss \underline{T} as the ‘underlying *n*-truss’, and to the functor lbl_T as the ‘labeling functor’. We can display the data of a labeled *n*-truss as a ‘labeled sequence’:

$$\mathbf{C} \xleftarrow{\text{lbl}_T} T_n \xrightarrow{p_n} T_{n-1} \xrightarrow{p_{n-1}} \dots \xrightarrow{p_2} T_1 \xrightarrow{p_1} T_0 = [0]$$

EXAMPLE 2.3.7 (A labeled 2-truss). Previously in Figure 2.39 we illustrated a 1-truss bundle labeled in a monoid. Since the base poset there happens to be a 1-truss, that in fact is already an example of a labeled 2-truss. —

EXAMPLE 2.3.8 (A labeled 3-truss). In Figure 2.43, we illustrate an open 3-truss labeled in the poset $[1] \times [1]$. As before, the labeling is indicated by color matching the objects of the truss total poset and their images in the labeling poset. —

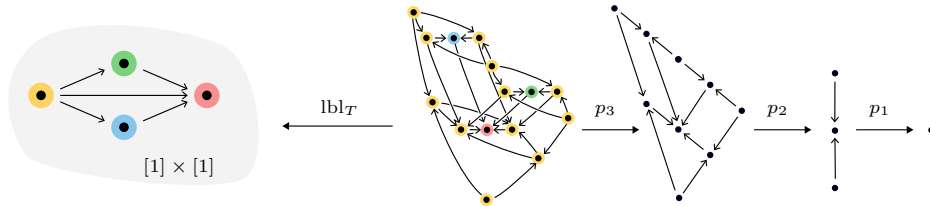

FIGURE 2.43. A labeled open 3-truss.

2.3.1.2. *n*-Truss bordisms and their composition. Recall that 1-trusses are a combinatorial model of stratified intervals, and 1-truss bordisms are designed to provide a combinatorial model of constructible bundles of stratified intervals over the stratified 1-simplex; as such, 1-truss bordisms constitute bundles of 1-trusses over the combinatorial 1-simplex. Similarly, *n*-truss bordisms are, intuitively and functionally speaking, bundles of *n*-trusses over the combinatorial 1-simplex.

DEFINITION 2.3.9 (*n*-Truss bordisms). An *n*-truss bordism is a sequence of 1-truss bundles

$$R_n \xrightarrow{p_n} R_{n-1} \xrightarrow{p_{n-1}} \dots \xrightarrow{p_2} R_1 \xrightarrow{p_1} R_0 = [1]$$

in which the base poset of each bundle is the total poset of the subsequent bundle. —

As in the case of *n*-trusses, we typically compress the sequence of bundles $\{R_i \xrightarrow{p_i} R_{i-1}\}$ to an indicative letter, referring to the whole *n*-truss bordism as for instance *R*. We call the face order poset (R_n, \trianglelefteq) the ‘total poset’ of the *n*-truss bordism, and abbreviate it simply if abusively R_n .

EXAMPLE 2.3.10 (A 2-truss bordism). In Figure 2.44, we illustrate a 2-truss bordism. The portion of the 2-truss bordism tower eventually projecting to $0 \in [1]$ is itself a 2-truss, and the portion eventually projecting to $1 \in [1]$ is similarly a 2-truss; the bordism provides a transition from that domain 2-truss to that codomain 2-truss. —

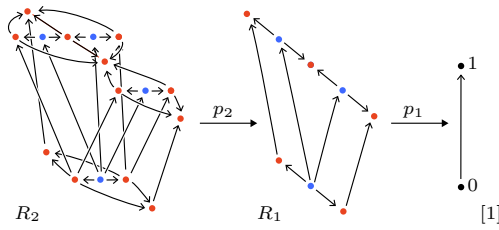

FIGURE 2.44. A 2-truss bordism.

DEFINITION 2.3.11 (Labeled *n*-truss bordism). Given a category *C*, a **C-labeled *n*-truss bordism** *R* is a pair $(\underline{R}, \text{lbl}_R)$ consisting of an *n*-truss bordism $\underline{R} = (R_n \rightarrow R_{n-1} \rightarrow \dots \rightarrow R_0 = [1])$ and a functor $\text{lbl}_R : R_n \rightarrow C$ from its total poset to the category. —

As expected we refer to the ‘underlying *n*-truss bordism’ \underline{R} and the ‘labeling functor’ lbl_R . We typically display the labeled *n*-truss bordism as a labeled sequence:

$$C \xleftarrow{\text{lbl}_R} R_n \xrightarrow{p_n} R_{n-1} \xrightarrow{p_{n-1}} \dots \xrightarrow{p_2} R_1 \xrightarrow{p_1} R_0 = [1]$$

Of course, *n*-truss bordisms labeled in the terminal category $C = *$ are simply *n*-truss bordisms.

EXAMPLE 2.3.12 (A labeled 2-truss bordism). In Figure 2.45, we illustrate a labeled 2-truss bordism. Note that the 2-truss bordism tower $R_2 \xrightarrow{p_2} R_1 \xrightarrow{p_1} R_0$ makes up half of the portion $T_3 \xrightarrow{p_3} T_2 \xrightarrow{p_2} T_1$ of the tower of the 3-truss in Figure 2.41. On the left is a labeling functor with poset target. The functor is indicated by color coding the preimages of the objects of the labeling poset; we also color code the preimages of the identity morphisms of the two maximal elements. —

TERMINOLOGY 2.3.13 (Domain and codomain of a labeled *n*-truss bordism). Given a *C*-labeled *n*-truss bordism $R = (\underline{R}, \text{lbl}_R)$, its ‘domain’ $\text{dom}(R)$ is the *C*-labeled *n*-truss $T^{(0)}$, whose underlying *n*-truss $\underline{T}^{(0)}$ is obtained by an iterated restriction of the tower of bundles \underline{R} to $0 \in [1]$, and whose labeling

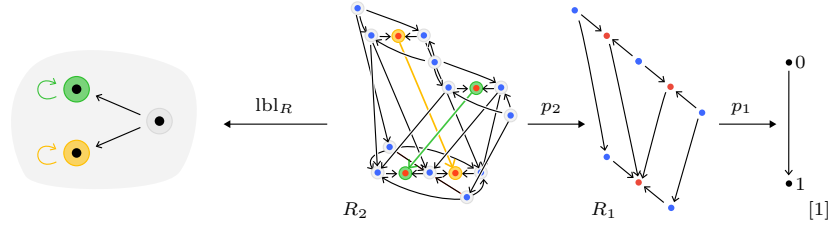
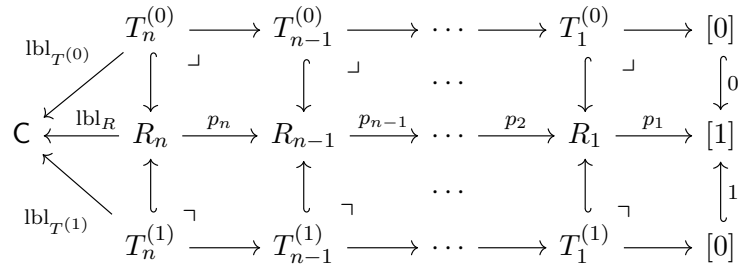

FIGURE 2.45. A labeled 2-truss bordism.

$\text{lbl}_{T^{(0)}}$ is the restriction of the labeling lbl_R to the total poset $T_n^{(0)}$ of $T^{(0)}$. Similarly the ‘codomain’ $\text{cod}(R)$ is the \mathbb{C} -labeled n -truss $T^{(1)}$ obtained by restricting the tower of bundles to $1 \in [1]$. That is, the domain and codomain are the top and bottom rows in the following diagram of 1-truss bundle restrictions, as in Construction 2.1.103.



We will suggestively denote the labeled n -truss bordism as a morphism $R : \text{dom}(R) \rightarrow \text{cod}(R)$. └─┘

Needless to say we would like to define a composition of n -truss bordisms (and their labeled counterparts). That is, given n -truss bordisms $R^{(01)} : T^{(0)} \rightarrow T^{(1)}$ and $R^{(12)} : T^{(1)} \rightarrow T^{(2)}$, we would like to form a composite n -truss bordism $R^{(02)} : T^{(0)} \rightarrow T^{(2)}$. As in the case of 1-truss bordisms, the composite n -truss bordism is given in terms of the composition of certain functorial relations, which we describe presently.

TERMINOLOGY 2.3.14 (Functorial relations of an n -truss bordism). For an n -truss bordism $R : T \rightarrow S$, its ‘ k -stage functorial relation’

$$\text{rel}_k^R : (T_k, \trianglelefteq) \rightarrow (S_k, \trianglelefteq)$$

is defined, for k -stage elements $t \in T_k$ and $s \in S_k$, by declaring

$$\text{rel}_k^R(t, s) \iff (t \trianglelefteq s) \text{ in } (R_k, \trianglelefteq).$$

Note that the relation is indeed functorial, simply because (R_k, \trianglelefteq) is a poset. └─┘

Note that in the case of 1-truss bordisms, we did not introduce separate notation for the (interchangeable) functorial relation and poset structures; see Terminology 2.1.72 and Notation 2.1.73. By contrast, in the case of

n -truss bordisms, it is clarifying to have the notational distinction between the functorial relation rel_k^R and the poset (R_k, \trianglelefteq) ; however these remain interchangeable in the following sense.

OBSERVATION 2.3.15 (n -Truss bordisms are determined by their functorial relations). For fixed n -trusses T and S , there is at most one n -truss bordism $R : T \rightarrow S$ with specified k -stage relations $\text{rel}_k^R : (T_k, \trianglelefteq) \rightarrow (S_k, \trianglelefteq)$; in other words, an n -truss bordism with given domain and codomain is determined by its associated functorial relations.

Specifically, given n -trusses T and S , along with k -stage relations $\text{rel}_k^R : (T_k, \trianglelefteq) \rightarrow (S_k, \trianglelefteq)$, the n -truss bordism R is necessarily given as follows:

- › the set R_k is the union of the k -stage sets T_k and S_k , and the projection $R_k \rightarrow R_{k-1}$ is the union of the projections $T_k \rightarrow T_{k-1}$ and $S_k \rightarrow S_{k-1}$;
- › the face order poset (R_k, \trianglelefteq) restricts to the face order posets (T_k, \trianglelefteq) and (S_k, \trianglelefteq) , and there is a face poset arrow $(t \in T_k) \trianglelefteq (s \in S_k)$ exactly when there is a relation $\text{rel}_k^R(t, s)$;
- › the frame order poset (R_k, \preceq) is simply the union of the frame order posets (T_k, \preceq) and (S_k, \preceq) ;
- › the dimension map $\dim : (R_k, \trianglelefteq) \rightarrow [1]^{\text{op}}$ is determined element-wise by the dimension maps on the posets (T_k, \trianglelefteq) and (S_k, \trianglelefteq) . —

Leveraging this observation, we may now attempt to define composition of n -truss bordisms via the composition of the associated k -stage functorial relations.

DEFINITION 2.3.16 (Composition of n -truss bordisms). Given n -truss bordisms $R^{(01)} : T^{(0)} \rightarrow T^{(1)}$ and $R^{(12)} : T^{(1)} \rightarrow T^{(2)}$, the **composite n -truss bordism** $R^{(02)} \equiv R^{(12)} \circ R^{(01)} : T^{(0)} \rightarrow T^{(2)}$ is the n -truss bordism whose functorial relations are the composites of the functorial relations of the component bordisms; that is, for all $1 \leq k \leq n$, the composite k -stage functorial relation is

$$\text{rel}_k^{R^{(02)}} := \text{rel}_k^{R^{(12)}} \circ \text{rel}_k^{R^{(01)}}. \quad \text{—}$$

Of course, it is not immediately clear that the given collection of composite functorial relations $\{\text{rel}_k^{R^{(12)}} \circ \text{rel}_k^{R^{(01)}}\}$ is in fact the collection of k -stage relations of an n -truss bordism $R^{(02)}$; that is, it remains to show that this definition indeed specifies a composite n -truss bordism, as its phrasing presupposes. Allowing for now that presupposition, we may attempt to define the more general labeled composition, as follows.

DEFINITION 2.3.17 (Composition of labeled n -truss bordisms). Given composable \mathbf{C} -labeled n -truss bordisms $R^{(01)} \equiv (\underline{R}^{(01)}, \text{lbl}_{R^{(01)}})$ and $R^{(12)} \equiv (\underline{R}^{(12)}, \text{lbl}_{R^{(12)}})$, the **composite labeled n -truss bordism** $R^{(02)} \equiv R^{(12)} \circ R^{(01)}$ is the labeled n -truss bordism $(\underline{R}^{(02)}, \text{lbl}_{R^{(02)}})$, whose underlying n -truss bordism is $\underline{R}^{(02)} := \underline{R}^{(12)} \circ \underline{R}^{(01)}$ and whose labeling is given by

$$\text{lbl}_{R^{(02)}}(x_0 \trianglelefteq x_2) := \text{lbl}_{R^{(12)}}(x_1 \trianglelefteq x_2) \circ \text{lbl}_{R^{(01)}}(x_0 \trianglelefteq x_1)$$

whenever $x_0 \leq x_1$ and $x_1 \leq x_2$ are composable arrows in the total posets $\underline{R}_n^{(01)}$ and $\underline{R}_n^{(12)}$ respectively. ---

It is by no means evident that the value of the labeling functor $\text{lbl}_{R^{(02)}}(x_0 \leq x_2)$ does not depend on the factorization $x_0 \leq x_1 \leq x_2$; it thus remains to be verified that this definition indeed specifies such a functor, as it implicitly claims to.

LEMMA 2.3.18 (Composition of labeled n -truss bordisms is well defined). *The specification in Definition 2.3.16 provides a well-defined n -truss bordism $R^{(02)}$ with the given k -stage relations $\text{rel}_k^{R^{(02)}}$, and the specification in Definition 2.3.17 provides a well-defined labeling functor $\text{lbl}_{R^{(02)}} : R_n^{(02)} \rightarrow \mathbf{C}$ with the given labels $\text{lbl}_{R^{(02)}}(x_0 \leq x_2)$.*

A direct proof of this result would involve, among other things, a tower of inductive arguments each stage of which is itself a truss induction. We instead defer the matter until we can give a more nimble proof via an interleaved induction involving the classification of n -truss bundles; Lemma 2.3.18 will be established as part of Lemma 2.3.48.

EXAMPLE 2.3.19 (Composition of 2-truss bordisms). In Figure 2.46 we illustrate two composable 2-truss bordisms

$$\begin{aligned} R^{(12)} &= (R_2^{(12)} \xrightarrow{p_2^{(12)}} R_1^{(12)} \xrightarrow{p_1^{(12)}} [1]) \\ R^{(01)} &= (R_2^{(01)} \xrightarrow{p_2^{(01)}} R_1^{(01)} \xrightarrow{p_1^{(01)}} [1]) \end{aligned}$$

and their composite $R^{(12)} \circ R^{(01)} =: R^{(02)} = (R_2^{(02)} \xrightarrow{p_2^{(02)}} R_1^{(02)} \xrightarrow{p_1^{(02)}} [1])$. For legibility we have drawn only the generating arrows at all stages of the bordisms. Note that the 1-truss bordisms $R_1^{(01)}$, $R_1^{(12)}$, and their composite $R_1^{(02)}$ are exactly those depicted in Figure 2.16. ---

NOTATION 2.3.20 (Categories of labeled n -trusses and their bordisms). Given a category \mathbf{C} , the ‘category of \mathbf{C} -labeled n -trusses and their bordisms’, whose objects are \mathbf{C} -labeled n -trusses and whose morphisms are \mathbf{C} -labeled n -truss bordisms, will be denoted $n\text{TBord}_{//\mathbf{C}}$. ---

NOTATION 2.3.21 (The category of n -trusses and their bordisms). Of course, we may and will consider the case where the labeling is in the terminal category and thus carries no information whatsoever. The resulting ‘category of n -trusses and their bordisms’, with objects n -trusses and morphisms n -truss bordisms, will be denoted $n\text{TBord} \equiv n\text{TBord}_{//\ast}$. ---

Note that forgetting the labeling provides a functor $n\text{TBord}_{//\mathbf{C}} \rightarrow n\text{TBord}$.

OBSERVATION 2.3.22 (The terminal and initial n -trusses). The terminal object of $n\text{TBord}$ is the n -truss $\bar{\mathbb{T}}_0^n = (p_n, p_{n-1}, \dots, p_1)$ in which every bundle

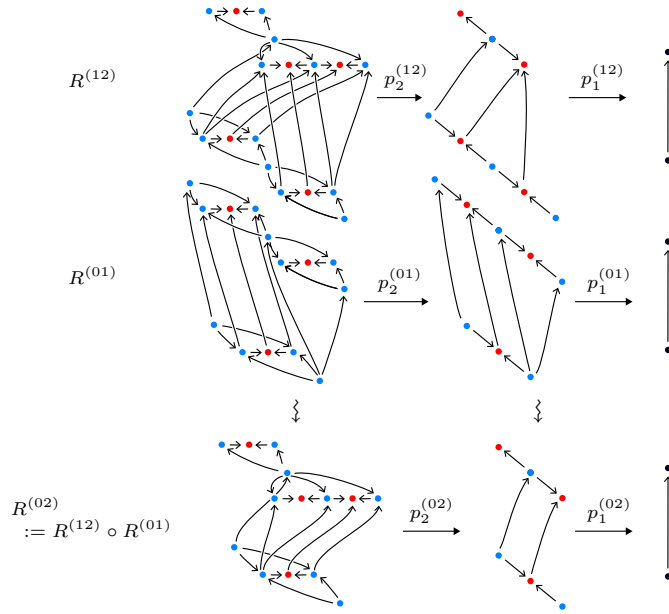

FIGURE 2.46. Composition of 2-truss bordisms.

p_i is trivial, with fiber the trivial closed 1-truss $\bar{\mathbb{T}}_0$. Similarly, the initial object of $n\text{TBord}$ is the n -truss $\bar{\mathbb{T}}_0^n = (p_n, p_{n-1}, \dots, p_1)$ in which every bundle p_i is trivial, with fiber the trivial open 1-truss $\bar{\mathbb{T}}_0$. —

2.3.1.3. The recursive category of n -trusses and their bordisms.

That there is a composition of labeled n -truss bordisms (if not yet obviously the specific one given before in Definitions 2.3.16 and 2.3.17) is an almost unsettlingly slick consequence of reinterpreting n -trusses and their bordisms as 1-truss-labeled $(n - 1)$ -trusses and their bordisms, and therefore by inductive iteration as 1-trusses labeled in 1-trusses labeled in 1-trusses and so on, as follows.

Recall from Definition 2.2.50 the labeled 1-truss bordism endofunctor $\text{TBord}_{// -}^1 : \text{Cat} \rightarrow \text{Cat}$, that takes a category \mathbb{C} to the category $\text{TBord}_{// \mathbb{C}}^1$ of \mathbb{C} -labeled 1-trusses and their bordisms. We promised to iterate that functor; here we go.

DEFINITION 2.3.23 (The iterated labeled 1-truss bordism functor). The n -fold iterated labeled 1-truss bordism functor, denoted $\text{TBord}_{// -}^n$, is the composite

$$\text{TBord}_{// -}^1 \circ \text{TBord}_{// -}^1 \circ \dots \circ \text{TBord}_{// -}^1 : \text{Cat} \rightarrow \text{Cat}$$

with n instances of the labeled 1-truss bordism functor. —

Naturally when $n = 0$, we take the functor $\text{TBord}_{// -}^0$ to be the identity functor on Cat . Evaluating the n -fold labeled bordism functor at a specific labeling category $\mathbb{C} \in \text{Cat}$ provides the following category.

NOTATION 2.3.24 (The recursive category of \mathbf{C} -labeled n -trusses and their bordisms). Given a category \mathbf{C} , the category $\mathbf{TBord}_{//\mathbf{C}}^n$ is called the ‘recursive category of \mathbf{C} -labeled n -trusses and their bordisms’. \square

The name of this category telegraphs an expectation about its objects and morphisms, which we make precise as follows.

LEMMA 2.3.25 (Equivalence of recursive and non-recursive categories). *There is an equivalence between the category of labeled n -trusses and their bordisms, and the recursive category of labeled n -trusses and their bordisms:*

$$n\mathbf{TBord}_{//\mathbf{C}} \simeq \mathbf{TBord}_{//\mathbf{C}}^n \quad .$$

We defer a proof until we are in the context of classification of n -truss bundles; Lemma 2.3.25 will be established along with Lemma 2.3.18 as part of Lemma 2.3.48.

Given this equivalence, we may and will refer to objects of $\mathbf{TBord}_{//\mathbf{C}}^n$ as n -trusses, and to morphisms of $\mathbf{TBord}_{//\mathbf{C}}^n$ as n -truss bordisms.

OBSERVATION 2.3.26 (n -Trusses as $(n - 1)$ -truss-labeled 1-trusses). The composition of the component functors in the iterated bordism functor $\mathbf{TBord}_{//\mathbf{C}}^n = (\mathbf{TBord}_{//\mathbf{C}}^1)^{\circ n} : \mathbf{Cat} \rightarrow \mathbf{Cat}$ is associative and therefore may be rebracketed variously as convenient. For instance, bracketing together the last $n - 1$ instances of the 1-truss bordism endofunctor provides the equality

$$\mathbf{TBord}_{//\mathbf{C}}^n = \mathbf{TBord}_{//\{\mathbf{TBord}_{//\mathbf{C}}^1\}}^{n-1}$$

That is, the (recursive) category of \mathbf{C} -labeled n -trusses and their bordisms is the (recursive) category of $(n - 1)$ -trusses and their bordisms *labeled* in the category of \mathbf{C} -labeled 1-trusses and their bordisms. Informally, we express (the unlabeled version of) this equality by saying ‘ n -trusses are 1-truss-labeled $(n - 1)$ -trusses’.

By contrast, the opposite bracketing provides the equality

$$\mathbf{TBord}_{//\mathbf{C}}^n = \mathbf{TBord}_{//\{\mathbf{TBord}_{//\mathbf{C}}^{n-1}\}}^1$$

That is, the (recursive) category of \mathbf{C} -labeled n -trusses and their bordisms is the category of 1-trusses and their bordisms *labeled* in the (recursive) category of \mathbf{C} -labeled $(n - 1)$ -trusses and their bordisms. Informally, we express this fact by saying ‘ n -trusses are $(n - 1)$ -truss-labeled 1-trusses’.

Of course, any intermediate bracketing will do just as well:

$$\mathbf{TBord}_{//\mathbf{C}}^n = \mathbf{TBord}_{//\{\mathbf{TBord}_{//\mathbf{C}}^{n-k}\}}^k$$

That is, n -trusses are $(n - k)$ -truss-labeled k -trusses. \square

2.3.2. *n*-Truss bundles and their classification. In the previous section, we developed the notion of *n*-trusses, providing a combinatorial model of towers of suitably framed stratified bundles, and of *n*-truss bordisms, providing a corresponding model of such towers over the stratified 1-simplex. Now we describe the natural generalization to *n*-truss bundles, which will model such framed stratified towers over more general stratified spaces.

SYNOPSIS. We introduce *n*-truss bundles as towers of 1-truss bundles that begin with an arbitrary base poset. We discuss the classification of *n*-truss bundles by functors into the recursive category of *n*-trusses and their bordisms, and use classification constructions to prove that the recursive category of *n*-trusses and their bordisms is equivalent to the category of *n*-trusses and their bordisms; in the process we establish that the latter category has a well-defined composition. Finally, we mention pullbacks, a non-commutative product, dualization, and suspension for *n*-truss bundles.

2.3.2.1. *n*-Truss bundles and bundle maps. We introduced *n*-trusses as towers of 1-truss bundles over a point, and *n*-truss bordisms as towers of 1-truss bundles over a combinatorial 1-simplex; the generalization to towers over arbitrary posets is direct, as follows.

DEFINITION 2.3.27 (*n*-Truss bundle). An ***n*-truss bundle** over a base poset B is a sequence of 1-truss bundles

$$T_n \xrightarrow{p_n} T_{n-1} \xrightarrow{p_{n-1}} \cdots \xrightarrow{p_2} T_1 \xrightarrow{p_1} T_0 = B$$

in which the base poset of each bundle is the total poset of the next bundle. —

We typically compress the sequence of bundles $\{T_i \xrightarrow{p_i} T_{i-1}\}$ to a single letter indicative of the maps, referring to the whole *n*-truss bundle as for instance p . We refer to the face order poset (T_n, \triangleleft) as the ‘total poset’ of the *n*-truss bundle and abbreviate it simply by T_n .

TERMINOLOGY 2.3.28 (Open and closed *n*-truss bundles). We call an *n*-truss bundle p ‘open’, respectively ‘closed’, when all its 1-truss bundles $p_i : T_i \rightarrow T_{i-1}$ are open, respectively closed. —

EXAMPLE 2.3.29 (The composition of 2-truss bordisms as a 2-truss bundle). Recall the 2-truss bordisms $R^{(01)}$ and $R^{(12)}$ and their composite $R^{(02)}$ from Figure 2.46. Identifying $R_0^{(ij)}$ with the poset $\{i \rightarrow j\}$, the union of the posets $R_0^{(ij)}$ yields the poset $T_0 := [2] = (0 \rightarrow 1 \rightarrow 2)$. The union of the posets $R_1^{(ij)}$ is the total poset T_1 of a 1-truss bundle over T_0 ; that 1-truss bundle was illustrated previously in Figure 2.23. The union of the posets $R_2^{(ij)}$ is the total poset T_2 of a 1-truss bundle over T_1 . Altogether this provides a 2-truss bundle $(T_2 \rightarrow T_1 \rightarrow T_0 = [2])$ over the 2-simplex, encoding that composition of 2-truss bordisms. —

REMARK 2.3.30 (Generating arrows of n -truss bundles). For an n -truss bundle $p = (T_n \xrightarrow{p_n} T_{n-1} \xrightarrow{p_{n-1}} \dots \xrightarrow{p_2} T_1 \xrightarrow{p_1} T_0 = B)$ over a base poset B , the covering relations $\text{cov}(T_i) \subset \text{mor}(T_i, \triangleleft)$ are determined by inductive application of [Construction 2.1.81](#), which specified the covering relation of the total poset of a 1-truss bundle in terms of the covering relation of its base poset. We refer to the morphisms of the covering relations $\text{cov}(T_i)$ as ‘generating arrows’ of the n -truss bundle. Note that we have already in some previous illustrations depicted only the generating arrows of n -trusses and n -truss bordisms, and will continue to do so as a matter of course for any n -truss bundles. \square

As fundamental as labelings will be for the subsequent combinatorial theory of stratified spaces, we can by now introduce them simply and without fuss as follows.

DEFINITION 2.3.31 (Labeled n -truss bundles). Given a poset B and a category \mathbf{C} , a **C-labeled n -truss bundle** p over B is a pair $(\underline{p}, \text{lbl}_p)$ consisting of an n -truss bundle \underline{p} , and a functor $\text{lbl}_p : T_n \rightarrow \mathbf{C}$ from the total poset of the bundle to the category. \square

Of course we refer to the ‘underlying n -truss bundle’ \underline{p} and the ‘labeling functor’ lbl_p . We display the labeled n -truss bundle as a labeled sequence:

$$\mathbf{C} \xleftarrow{\text{lbl}_p} T_n \xrightarrow{p_n} T_{n-1} \xrightarrow{p_{n-1}} \dots \xrightarrow{p_2} T_1 \xrightarrow{p_1} T_0 = B$$

Needless to say, n -truss bundles over base $B = [1]$ are simply n -truss bordisms, and over base $B = [0]$ are simply n -trusses.

DEFINITION 2.3.32 (Maps of labeled n -truss bundles). For categories \mathbf{C} and \mathbf{D} , let $p = \{T_i \xrightarrow{p_i} T_{i-1}\}$ be a \mathbf{C} -labeled n -truss bundle and let $q = \{S_i \xrightarrow{q_i} S_{i-1}\}$ be a \mathbf{D} -labeled n -truss bundle. A **map of labeled n -truss bundles** $F : p \rightarrow q$ is a pair $(\underline{F}, \text{lbl}_F)$ consisting of (1) a sequence $\underline{F} = (F_n, F_{n-1}, \dots, F_1, F_0)$, where $F_0 : T_0 \rightarrow S_0$ is a poset map and each pair $(F_i, F_{i-1}) : p_i \rightarrow q_i$ is a 1-truss bundle map (as in [Definition 2.1.87](#)), and (2) a functor $\text{lbl}_F : \mathbf{C} \rightarrow \mathbf{D}$ for which $((F_n, F_{n-1}), \text{lbl}_F)$ is a labeled 1-truss bundle map (as in [Definition 2.2.60](#)). \square

We display the data of a map $F \equiv (\underline{F}, \text{lbl}_F)$ as a commutative diagram:

$$\begin{array}{ccccccccccc} \mathbf{C} & \xleftarrow{\text{lbl}_p} & T_n & \xrightarrow{p_n} & T_{n-1} & \xrightarrow{p_{n-1}} & \dots & \xrightarrow{p_2} & T_1 & \xrightarrow{p_1} & T_0 \\ \text{lbl}_F \downarrow & & F_n \downarrow & & F_{n-1} \downarrow & & \dots & & F_1 \downarrow & & F_0 \downarrow \\ \mathbf{D} & \xleftarrow{\text{lbl}_q} & S_n & \xrightarrow{q_n} & S_{n-1} & \xrightarrow{q_{n-1}} & \dots & \xrightarrow{q_2} & S_1 & \xrightarrow{q_1} & S_0 \end{array}$$

As in the case of labeled 1-truss bundles, we refer to lbl_F as the ‘label category functor’, and to the sequence \underline{F} as the ‘underlying’ bundle map. We make explicit the following obvious specializations of the previous definition.

TERMINOLOGY 2.3.33 (Maps of n -truss bundles). For unlabeled n -truss bundles p and q , a ‘map of n -truss bundles’ $p \rightarrow q$ is a sequence of 1-truss bundle maps $p_i \rightarrow q_i$, that is just the first piece of data from the definition of maps of labeled n -truss bundles. Equivalently, a map of unlabeled n -truss bundles is a map of labeled n -truss bundles whose labelings are both in the terminal category. \square

TERMINOLOGY 2.3.34 (Maps of labeled n -trusses). For labeled n -trusses T and S , a ‘map of labeled n -trusses’ $T \rightarrow S$ is simply a map of labeled n -truss bundles whose base posets are both trivial. \square

TERMINOLOGY 2.3.35 (Maps of n -trusses). For n -trusses $T = \{T_i \xrightarrow{p_i} T_{i-1}\}$ and $S = \{S_i \xrightarrow{q_i} S_{i-1}\}$, a ‘map of n -trusses’ $T \rightarrow S$ is simply a sequence of 1-truss bundle maps $p_i \rightarrow q_i$. Equivalently, it is a map of n -truss bundles both of whose base posets are trivial, or a map of labeled n -trusses whose labelings are both in the terminal category. \square

Various basic conditions on labeled n -truss bundle maps carry over from the corresponding 1-truss versions, as follows.

TERMINOLOGY 2.3.36 (Label-preserving and base-preserving n -truss bundle maps). A labeled n -truss bundle map is ‘label preserving’ if the label category functor lbl_F is an identity, and is ‘base preserving’ if the underlying bundle map \underline{F} has its initial poset map F_0 being an identity. \square

TERMINOLOGY 2.3.37 (Singular, regular, and balanced labeled n -truss bundle maps). A labeled n -truss bundle map $F \equiv (\underline{F} = \{p_i \rightarrow q_i\}, \text{lbl}_F)$ is ‘singular’, ‘regular’, or ‘balanced’ if every component 1-truss bundle map $p_i \rightarrow q_i$ is such, respectively, in the sense of Terminology 2.1.88. \square

Componentwise composition of the sequence $\{p_i \rightarrow q_i\}$ of underlying bundle maps, along with composition of the label category functors, provides the following categories.

NOTATION 2.3.38 (Categories of n -trusses and n -truss bundles). Using the above notions of maps, we have the following four categories:

Tr_n n -Trusses and their maps.

LblTr_n Labeled n -trusses and their maps.

TrsBun_n n -Truss bundles and their maps.

LblTrsBun_n Labeled n -truss bundles and their maps.

We will also have particular need of the following subcategory of TrsBun_n :

$\text{Tr}_n(B)$ n -Truss bundles over the poset B and base-preserving maps.

As before, the decoration $\overset{\circ}{\text{T}}$ or $\bar{\text{T}}$ will indicate the restriction to the open objects and regular maps, or closed objects and singular maps, respectively. \square

REMARK 2.3.39 (Enriched categories of n -trusses and n -truss bundles). The hom-sets $\text{Tr}_n(T, S)$ in the category Tr_n are a priori, of course, discrete; but we may instead regard $\text{Tr}_n(T, S)$ as a poset, whose objects are n -truss

maps and whose arrows are the natural transformations $\nu : E_n \Rightarrow F_n$ of the total poset maps $E_n, F_n : T_n \rightarrow S_n$ of the n -truss maps $E, F : T \rightarrow S$. (Note that if such a natural transformation exists, it is unique, and such a natural transformation induces natural transformations $E_i \Rightarrow F_i$ at every i -stage of the truss towers.) Altogether this provides a **Pos**-enrichment of the category \mathbf{Tr}_n . Regarding a poset as a topological space via its specialization topology then provides a $k\mathbf{Top}$ -enrichment of the category \mathbf{Tr}_n . (Here $k\mathbf{Top}$ denotes the category of compactly generated spaces; see [Convention B.1.1](#) and [Notation B.1.2](#) and the intervening discussion.) All the same comments apply to the case of truss bundles, and we therefore have the following two $k\mathbf{Top}$ -enriched categories:

- $\mathcal{T}\mathcal{I}\mathcal{S}_n$ n -Trusses and their $k\mathbf{Top}$ -space of maps.
- $\mathcal{T}\mathcal{I}\mathcal{S}_n(B)$ n -Truss bundles over the poset B and their $k\mathbf{Top}$ -space of base-preserving maps.

These enrichments provide a subtle additional structure beyond the discrete categories of trusses and truss bundles, but critically they should not be considered as being $(\infty, 1)$ -categorical models, as the hom-spaces are not weak Hausdorff. —

TERMINOLOGY 2.3.40 (Restriction of labeled n -truss bundles). Given a \mathbf{C} -labeled n -truss bundle $p \equiv (p = (p_n, p_{n-1}, \dots, p_1), \text{lbl}_p)$ over a poset B , and a subposet $A \hookrightarrow B$, the ‘restriction’ of the labeled bundle to the subposet is the \mathbf{C} -labeled n -truss bundle $p|_A$ given by the upper row in the following diagram:

$$\begin{array}{ccccccc}
 \text{lbl}_{p|_A} & T_n|_A & \xrightarrow{p_n|_A} & T_{n-1}|_A & \xrightarrow{p_{n-1}|_A} & \cdots & \xrightarrow{p_2|_A} & T_1|_A & \xrightarrow{p_1|_A} & A \\
 \swarrow & \downarrow & \lrcorner & \downarrow & \lrcorner & \cdots & \downarrow & \lrcorner & \downarrow & \\
 \mathbf{C} & & & & & & & & & \\
 \swarrow & T_n & \xrightarrow{p_n} & T_{n-1} & \xrightarrow{p_{n-1}} & \cdots & \xrightarrow{p_2} & T_1 & \xrightarrow{p_1} & B \\
 \text{lbl}_p & & & & & & & & &
 \end{array}$$

Here each square is a pullback, in fact a restriction, of 1-truss bundles. This process provides in particular a functor $-|_A : \mathbf{Tr}_n(B) \rightarrow \mathbf{Tr}_n(A)$. —

REMARK 2.3.41 (Balanced isomorphism for labeled n -truss bundles). Generalizing [Remark 2.2.66](#), balanced label- and base-preserving n -truss bundle isomorphisms preserve all structural data (face orders, frame orders, dimension maps at all stages, projection towers, labeling functors), and are unique when they exist. As before, there is therefore no need to distinguish between distinct but balanced label- and base-preservingly isomorphic labeled n -truss bundles. —

Given a 1-truss bundle, we could retain only the total poset, or retain only the base poset. The corresponding constructions for n -truss bundles involve discarding either part of the tail or part of the head of the constituent sequence of 1-truss bundles, as follows.

CONSTRUCTION 2.3.42 (Upper truncation of n -truss bundles). The ‘upper $(n - k)$ -truncation functor’

$$(-)_{>k} : \mathbf{LblTrsBun}_n \rightarrow \mathbf{LblTrsBun}_{n-k}$$

takes a labeled n -truss bundle $p = (\underline{p} = (p_n, p_{n-1}, \dots, p_1), \text{lbl}_p)$ to the labeled $(n - k)$ -truss bundle $p_{>k} = (\underline{p}_{>k} = (p_n, p_{n-1}, \dots, p_{k+1}), \text{lbl}_p)$ given by the first $(n - k)$ -many 1-truss bundles in the tower, with the labeling of the total poset. (When $k = n$, we interpret this truncation to yield just the total poset of the n -truss bundle, with its labeling functor.) —

CONSTRUCTION 2.3.43 (Lower truncation of n -truss bundles). The ‘lower k -truncation functor’

$$(-)_{\leq k} : \mathbf{LblTrsBun}_n \rightarrow \mathbf{TrsBun}_k$$

takes a labeled n -truss bundle $p = (\underline{p} = (p_n, p_{n-1}, \dots, p_1), \text{lbl}_p)$ to the unlabeled k -truss bundle $p_{\leq k} = (p_k, p_{k-1}, \dots, p_1)$ given by the last k -many 1-truss bundles in the tower. (When $k = 0$, we interpret this truncation to yield just the base poset of the n -truss bundle.) —

2.3.2.2. Classification and totalization for n -truss bundles. Recall from Observation 2.2.73 that \mathbf{C} -labeled 1-truss bundles are classified by functors into the category $\mathbf{TBord}_{//\mathbf{C}}^1$ of \mathbf{C} -labeled 1-trusses and their bordisms. We now discuss the analogous classification in the n -truss case: \mathbf{C} -labeled n -truss bundles are classified by functors into the *recursive* category $\mathbf{TBord}_{//\mathbf{C}}^n$ of \mathbf{C} -labeled n -trusses and their bordisms. Along the way we will finally establish that that recursive category is equivalent to the category $n\mathbf{TBord}_{//\mathbf{C}}$ of \mathbf{C} -labeled n -trusses and their bordisms.

CONSTRUCTION 2.3.44 (Classifying functors of labeled n -truss bundles). We describe a map

$$p \equiv (\underline{p} = (p_n, p_{n-1}, \dots, p_1), \text{lbl}_p : T_n \rightarrow \mathbf{C}) \quad \mapsto \quad (\chi_p : B \rightarrow \mathbf{TBord}_{//\mathbf{C}}^n)$$

that takes a \mathbf{C} -labeled n -truss bundle $p \equiv (\underline{p}, \text{lbl}_p)$ over a poset B , with underlying bundle $\underline{p} = (p_n, p_{n-1}, \dots, p_1)$ and labeling functor $\text{lbl}_p : T_n \rightarrow \mathbf{C}$, to an associated **classifying functor** $\chi_p : B \rightarrow \mathbf{TBord}_{//\mathbf{C}}^n$.

We construct the functor χ_p inductively, as follows.

- › Specify an initial functor $\chi_p^n := \text{lbl}_p : T_n \rightarrow \mathbf{C}$ as the given labeling functor.
- › Inductively in descending i , consider the $(\mathbf{TBord}_{//\mathbf{C}}^{n-i})$ -labeled 1-truss bundle $(p_i : T_i \rightarrow T_{i-1}, \chi_p^i : T_i \rightarrow \mathbf{TBord}_{//\mathbf{C}}^{n-i})$; define

$$\chi_p^{i-1} : T_{i-1} \rightarrow \mathbf{TBord}_{//(\mathbf{TBord}_{//\mathbf{C}}^{n-i})}^1 = \mathbf{TBord}_{//\mathbf{C}}^{n-i+1}$$

to be the classifying functor of that labeled 1-truss bundle (p_i, χ_p^i) .

- › Finally set $\chi_p := \chi_p^0 : B \rightarrow \mathbf{TBord}_{//\mathbf{C}}^n$. —

Notice that in the inductive construction above, we used the fact (see [Observation 2.3.26](#)) that $\mathbf{TBord}_{//\mathbf{C}}^1(\mathbf{TBord}_{//\mathbf{C}}^{n-i})$ is a suitable expression for $\mathbf{TBord}_{//\mathbf{C}}^{n-i+1}$.

Conversely, to a classifying functor we may associate a total labeled bundle, as follows; the construction will simply invert each inductive step of the preceding construction of classifying functors.

CONSTRUCTION 2.3.45 (Total labeled n -truss bundles of classifying functors). We describe a map

$$(\mathbf{F} : B \rightarrow \mathbf{TBord}_{//\mathbf{C}}^n) \mapsto \pi_{\mathbf{F}} \equiv (\pi_{\mathbf{F}} = (\pi_{\mathbf{F}}^n, \pi_{\mathbf{F}}^{n-1}, \dots, \pi_{\mathbf{F}}^1), \mathbf{lbl}_{\mathbf{F}} : \mathbf{Tot}^n \mathbf{F} \rightarrow \mathbf{C})$$

that takes a functor $\mathbf{F} : B \rightarrow \mathbf{TBord}_{//\mathbf{C}}^n$ to an associated **total C-labeled n -truss bundle** $\pi_{\mathbf{F}} \equiv (\pi_{\mathbf{F}}, \mathbf{lbl}_{\mathbf{F}})$.

We construct the labeled n -truss bundle $\pi_{\mathbf{F}}$ inductively, as follows.

- › Specify an initial functor $\mathbf{lbl}_{\mathbf{F}}^0 : \mathbf{Tot}^0 \mathbf{F} \rightarrow \mathbf{TBord}_{//\mathbf{C}}^n$ to be the given functor $\mathbf{F} : B \rightarrow \mathbf{TBord}_{//\mathbf{C}}^n$.
- › Inductively in ascending i , consider the classifying functor

$$\mathbf{lbl}_{\mathbf{F}}^{i-1} : \mathbf{Tot}^{i-1} \mathbf{F} \rightarrow \mathbf{TBord}_{//\mathbf{C}}^{n-i+1} = \mathbf{TBord}_{//(\mathbf{TBord}_{//\mathbf{C}}^{n-i})}^1;$$

define $(\pi_{\mathbf{F}}^i : \mathbf{Tot}^i \mathbf{F} \rightarrow \mathbf{Tot}^{i-1} \mathbf{F}, \mathbf{lbl}_{\mathbf{F}}^i : \mathbf{Tot}^i \mathbf{F} \rightarrow \mathbf{TBord}_{//\mathbf{C}}^{n-i})$ to be the total $(\mathbf{TBord}_{//\mathbf{C}}^{n-i})$ -labeled 1-truss bundle of that classifying functor.

- › Finally set $\pi_{\mathbf{F}} := (\pi_{\mathbf{F}}^n, \pi_{\mathbf{F}}^{n-1}, \dots, \pi_{\mathbf{F}}^1)$ and $\mathbf{lbl}_{\mathbf{F}} := \mathbf{lbl}_{\mathbf{F}}^n : \mathbf{Tot}^n \mathbf{F} \rightarrow \mathbf{C}$. —

REMARK 2.3.46 (Unwinding the classification constructions). Consider the tower of intermediate classifying maps arising in the preceding inductive classification construction; we display, as follows, the form of this tower in the case of a \mathbf{C} -labeled 3-truss bundle p with underlying 3-truss bundle $T_3 \xrightarrow{p_3} T_2 \xrightarrow{p_2} T_1 \xrightarrow{p_1} T_0$ and labeling functor $\mathbf{lbl}_p : T_3 \rightarrow \mathbf{C}$.

$$\begin{array}{ccc} T_3 & \xrightarrow{\chi_p^3 = \mathbf{lbl}_p} & \mathbf{C} \\ p_3 \downarrow & & \\ T_2 & \xrightarrow{\chi_p^2} & \mathbf{TBord}_{//\mathbf{C}}^1 \\ p_2 \downarrow & & \\ T_1 & \xrightarrow{\chi_p^1} & \mathbf{TBord}_{//\mathbf{C}}^2 = \mathbf{TBord}_{//\mathbf{TBord}_{//\mathbf{C}}^1}^1 \\ p_1 \downarrow & & \\ T_0 & \xrightarrow{\chi_p^0} & \mathbf{TBord}_{//\mathbf{C}}^3 = \mathbf{TBord}_{//\mathbf{TBord}_{//\mathbf{C}}^2}^1 \end{array}$$

Explicitly, the \mathbf{C} -labeled 1-truss bundle (p_3, χ_p^3) is classified by χ_p^2 , then the labeled 1-truss bundle (p_2, χ_p^2) is classified by χ_p^1 , and finally the labeled

1-truss bundle (p_1, χ_p^1) is classified by χ_p^0 . Each of the following subsets of the diagram thus determines the entire \mathbf{C} -labeled 3-truss bundle:

- (1) by definition the bundles p_1 , p_2 , and p_3 , together with the functor $\chi_p^3 = \text{lbl}_p$;
- (2) the bundles p_1 and p_2 , together with the functor χ_p^2 ;
- (3) the bundle p_1 together with the functor χ_p^1 ;
- (4) just by itself the functor χ_p^0 . —

EXAMPLE 2.3.47 (Classification and totalization for a labeled 3-truss bundle). As an example of the iterated classification procedure described and displayed in the previous remark, in Figure 2.47 we depict the classifying tower of a 3-truss (with trivial labeling category for simplicity). Consider having, at the outset, the tower of 1-truss bundles $T_3 \xrightarrow{p_3} T_2 \xrightarrow{p_2} T_1 \xrightarrow{p_1} T_0$ (with trivial labeling $\text{lbl}_p : T_3 \rightarrow *$).

First, form the classifying functor

$$\chi_p^2 := \chi_{(p_3, \text{lbl}_p)} : T_2 \rightarrow \mathbf{TBord}_{//_*}^1 \equiv \mathbf{TBord}^1$$

of the (trivially labeled) 1-truss bundle $T_3 \xrightarrow{p_3} T_2$. Note that this classifying functor happens to factor as $T_2 \rightarrow \mathbf{BF} \hookrightarrow \mathbf{TBord}^1$, where \mathbf{BF} is the opposite flip flop monoid described in Example 2.2.59. That factorization allows us to consider the a priori \mathbf{TBord}^1 -labeled 1-truss bundle (p_2, χ_p^2) as being \mathbf{BF} -labeled, and therefore specified by color-coding the arrows of the poset T_2 ; in fact, this \mathbf{BF} -labeled bundle is the one that appeared in Figure 2.39.

Second, form the classifying functor

$$\chi_p^1 := \chi_{(p_2, \chi_p^2)} : T_1 \rightarrow \mathbf{TBord}_{//\mathbf{BF}}^1 \hookrightarrow \mathbf{TBord}_{//\mathbf{TBord}^1}^1 \equiv \mathbf{TBord}^2$$

of the \mathbf{BF} -labeled 1-truss bundle (p_2, χ_p^2) . That functor is similarly specified by color-coding the arrows of the poset T_1 ; again in fact this $(\mathbf{TBord}_{//\mathbf{BF}}^1)$ -labeled bundle previously appeared in Figure 2.40.

Third, form the classifying functor

$$\chi_p \equiv \chi_p^0 := \chi_{(p_1, \chi_p^1)} : T_0 \rightarrow \mathbf{TBord}_{//\mathbf{BF}}^2 \hookrightarrow \mathbf{TBord}_{//\mathbf{TBord}^1}^2 \equiv \mathbf{TBord}^3$$

of the $(\mathbf{TBord}_{//\mathbf{BF}}^1)$ -labeled 1-truss bundle (p_1, χ_p^1) . In this case, where the base poset T_0 is a point, that final classifying functor is rather tautological, merely picking out the point of \mathbf{TBord}^3 indicating the given 3-truss. But of course for bundles with nontrivial base poset, even this final classifying functor would trace out an informative diagram in the target classifying category \mathbf{TBord}^3 . —

Equipped with the classification and totalization constructions for labeled n -truss bundles, we may now establish together two facts previously deferred: that the composition of labeled n -truss bordisms (from Definitions 2.3.16 and 2.3.17) is well-defined (as claimed in Lemma 2.3.18), and that that category is equivalent to the recursive category of labeled n -trusses and their bordisms (as claimed in Lemma 2.3.25).

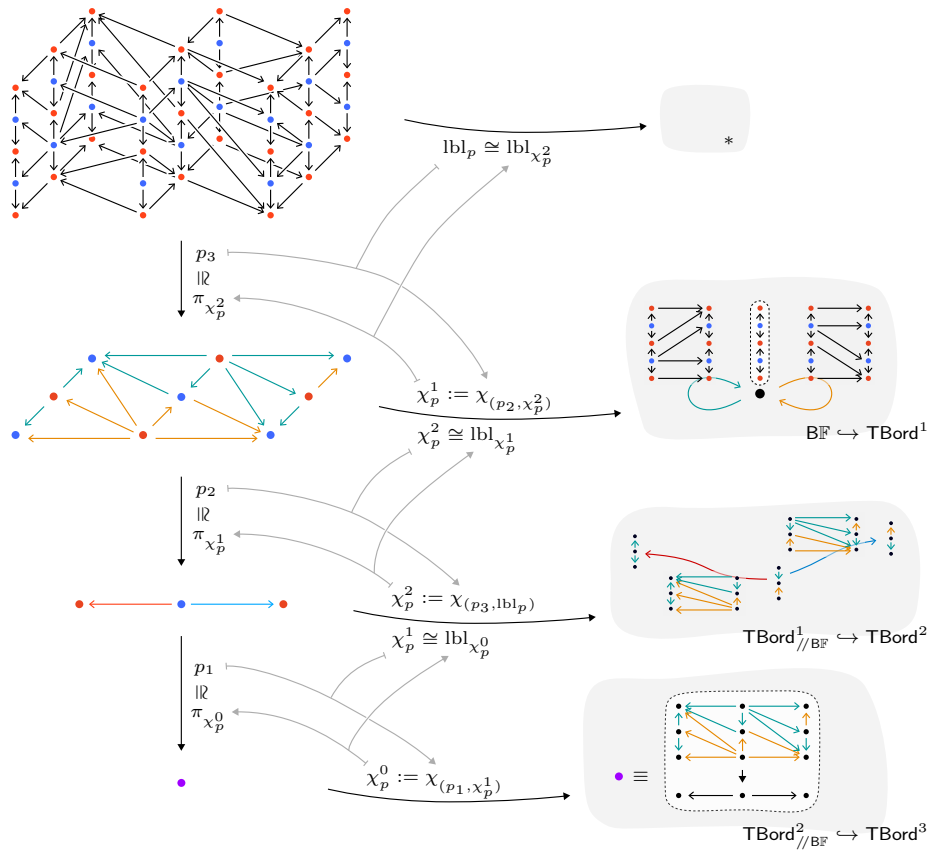

FIGURE 2.47. The classifying tower of a 3-truss.

LEMMA 2.3.48 (Categories of n -trusses and their bordisms). *The composition of labeled n -truss bordisms is well-defined, and the resulting category of labeled n -trusses and their bordisms is equivalent to the recursive category of labeled n -trusses and their bordisms:*

$$\chi_- : n\text{TBord}_{//C} \simeq \text{TBord}_{//C}^n : \pi_-$$

This equivalence is by a functor χ_- , that takes n -trusses and bordisms to the images of their classifying functors in the recursive category, and a functor π_- , that takes objects and morphisms of the recursive category to their total n -trusses and bordisms.

PROOF. The case $n = 1$ was established previously in Lemma 2.2.43 (since $1\text{TBord}_{//C}$ and $\text{TBord}_{//C}^1$ are identical by definition). Assume inductively that $(n - 1)\text{TBord}_{//C}$ has well-defined composition, and that we have the desired equivalence

$$\chi_- : (n - 1)\text{TBord}_{//C} \simeq \text{TBord}_{//C}^{n-1} : \pi_- \quad .$$

Setting the labeling category itself to be $\text{TBord}_{//C}^1$, we have in particular that the category $(n - 1)\text{TBord}_{//\{\text{TBord}_{//C}^1\}}$ is well-defined and we have the

equivalence

$$\chi_- : (n-1)\mathbf{TBord}_{//\{\mathbf{TBord}^1_{//C}\}} \simeq \mathbf{TBord}^{n-1}_{//\{\mathbf{TBord}^1_{//C}\}} : \pi_- .$$

We first show that $n\mathbf{TBord}_{//C}$ has well-defined composition. We do this in a roundabout fashion by providing a (necessarily well defined) labeled n -truss bordism $R^{(02)}$, and then showing that that labeled bordism $R^{(02)}$ has the underlying k -stage relations specified by Definition 2.3.16 and the labeling functor factorization specified by Definition 2.3.17.

Consider two composable labeled n -truss bordisms $R^{(01)} : T^{(0)} \rightarrow T^{(1)}$ (with $R^{(01)} = (\underline{R}^{(01)}, \text{lbl}_{R^{(01)}})$) and $R^{(12)} : T^{(1)} \rightarrow T^{(2)}$ (with $R^{(12)} = (\underline{R}^{(12)}, \text{lbl}_{R^{(12)}})$). Let $\chi_{R^{(01)}} : [1] \rightarrow \mathbf{TBord}^n_{//C}$ and $\chi_{R^{(12)}} : [1] \rightarrow \mathbf{TBord}^n_{//C}$ be the classifying functors of the labeled n -truss bordisms $R^{(01)}$ and $R^{(12)}$. Considered as morphisms in $\mathbf{TBord}^n_{//C}$, those functors admit a composite $\chi_{R^{(12)}} \circ \chi_{R^{(01)}} : [1] \rightarrow \mathbf{TBord}^n_{//C}$. We may thus form the total labeled n -truss bundle of that composite:

$$R^{(02)} := \pi_{(\chi_{R^{(12)}} \circ \chi_{R^{(01)}})}$$

For simplicity, we identify bundles up to (label- and base-preserving) balanced isomorphism; observe that $\text{dom}(R^{(02)}) = T^{(0)}$ and $\text{cod}(R^{(02)}) = T^{(2)}$.

We now verify that the underlying bundle $\underline{R}^{(02)}$ has k -stage relations $\text{rel}_k^{R^{(02)}}$ being precisely the composite relations $\text{rel}_k^{R^{(12)}} \circ \text{rel}_k^{R^{(01)}}$, as required by Definition 2.3.16. Let $\underline{R}^{(02)} = (p_n^{(02)}, p_{n-1}^{(02)}, \dots, p_1^{(02)})$, $\underline{R}^{(01)} = (p_n^{(01)}, p_{n-1}^{(01)}, \dots, p_1^{(01)})$, and $\underline{R}^{(12)} = (p_n^{(12)}, p_{n-1}^{(12)}, \dots, p_1^{(12)})$ denote the constituent 1-truss bundles. Inductively we may assume $\text{rel}_k^{R^{(02)}} = \text{rel}_k^{R^{(12)}} \circ \text{rel}_k^{R^{(01)}}$ for $k < n$, and then argue that $\text{rel}_n^{R^{(02)}} = \text{rel}_n^{R^{(12)}} \circ \text{rel}_n^{R^{(01)}}$ as follows.

- ▷ If $(x_0, x_2) \in \text{rel}_n^{R^{(02)}}$, then $p_n^{(02)}(x_0, x_2) =: (x'_0, x'_2) \in \text{rel}_{n-1}^{R^{(01)}}$. By induction, there exists some $x'_1 \in T_{n-1}^{(1)}$ with $(x'_0, x'_1) \in \text{rel}_{n-1}^{R^{(01)}}$ and $(x'_1, x'_2) \in \text{rel}_{n-1}^{R^{(12)}}$. Now observe

$$\chi_{p_n^{(02)}}(x'_0 \preceq x'_2) = \chi_{p_n^{(12)}}(x'_1 \preceq x'_2) \circ \chi_{p_n^{(01)}}(x'_0 \preceq x'_1)$$

It follows from the definition of composition of 1-truss bordisms as composition of relations (see Definition 2.1.51) that there is some $x_1 \in T_n^{(1)}$ with $p_n^{(01)}(x_1) = x'_1 = p_n^{(12)}(x_1)$ and with $(x_0, x_1) \in \text{rel}_n^{R^{(01)}}$ and $(x_1, x_2) \in \text{rel}_n^{R^{(12)}}$.

- ▷ Conversely, if $\text{rel}_n^{R^{(01)}}(x_0, x_1)$ and $\text{rel}_n^{R^{(12)}}(x_1, x_2)$, then $p_n^{(01)}(x_0, x_1) =: (x'_0, x'_1) \in \text{rel}_{n-1}^{R^{(01)}}$ and $p_n^{(12)}(x_1, x_2) =: (x'_1, x'_2) \in \text{rel}_{n-1}^{R^{(12)}}$. By induction we have $(x'_0, x'_2) \in \text{rel}_{n-1}^{R^{(02)}}$; the previously displayed equality of classifying functors implies that $(x_0, x_2) \in \text{rel}_n^{R^{(02)}}$.

That much verifies that the underlying bundle $\underline{R}^{(02)}$ is well-defined by the composites of the k -stage relations of the underlying bundles $\underline{R}^{(01)}$ and $\underline{R}^{(12)}$.

Next, again by the same displayed equality of classifying functors (and the fact that that equality holds for any factorizing element $x'_1 \in T_{n-1}^{(1)}$), the labeling functor $\text{lbl}_{R(02)}$ satisfies the labeling functor factorization

$$\text{lbl}_{R(02)}(x_0 \leq x_2) := \text{lbl}_{R(12)}(x_1 \leq x_2) \circ \text{lbl}_{R(01)}(x_0 \leq x_1),$$

as specified by Definition 2.3.17; that much ensures that the labeling functor is well-defined and altogether that $n\text{TBord}_{//\mathcal{C}}$ indeed forms a category.

It remains to show that classification and totalization form an equivalence between $n\text{TBord}_{//\mathcal{C}}$ and $\text{TBord}_{//\mathcal{C}}^n$. With the inductive assumption (applied to the labeling category $\text{TBord}_{//\mathcal{C}}^1$), it suffices to check that

$$\chi_- : n\text{TBord}_{//\mathcal{C}} \simeq (n-1)\text{TBord}_{//\{\text{TBord}_{//\mathcal{C}}^1\}} : \pi_-$$

Observe that this classification construction χ_- and totalization construction π_- are functorial, and are inverse on objects and morphisms up to label-preserving balanced bundle isomorphism. \square

The correspondence, via Constructions 2.3.44 and 2.3.45, between labeled n -truss bundles and functors into the (recursive) category of labeled n -trusses and their bordisms, is functorial, with respect to a notion of bordisms of bundles, generalizing the previous Definitions 2.1.96 and 2.2.70, as follows.

DEFINITION 2.3.49 (Bordisms of labeled n -truss bundles and their composition). Given \mathcal{C} -labeled n -truss bundles p and q over a poset B , a **\mathcal{C} -labeled n -truss bundle bordism** $u : p \rightarrow q$ is a \mathcal{C} -labeled n -truss bundle u over $B \times [1]$ such that $u|_{B \times \{0\}} = p$ and $u|_{B \times \{1\}} = q$.

The **composition** of two such labeled bordisms $u : p \rightarrow q$ and $v : q \rightarrow r$ is the labeled bordism $v \circ u : p \rightarrow r$ whose iterated restriction $(v \circ u)|_{\{x\} \times [1]}$ is the composite labeled bordism $v|_{\{x\} \times [1]} \circ u|_{\{x\} \times [1]}$, for all elements $x \in B$. ---

Note that, given a \mathcal{C} -labeled n -truss bundle bordism $u : p \rightarrow q$, its classifying functor $\chi_u : B \times [1] \rightarrow \text{TBord}_{//\mathcal{C}}^n$ may also be considered as a ‘classifying natural transformation’ $\chi_p \Rightarrow \chi_q : B \rightarrow \text{TBord}_{//\mathcal{C}}^n$.

NOTATION 2.3.50 (Category of labeled n -truss bundles and their bordisms). For a fixed base poset B and a category \mathcal{C} , the ‘category of \mathcal{C} -labeled n -truss bundles and their bordisms’, whose objects are \mathcal{C} -labeled n -truss bundles over B and whose morphisms are \mathcal{C} -labeled n -truss bundle bordisms, will be denoted $n\text{TBord}(B)_{//\mathcal{C}}$. ---

REMARK 2.3.51 (Isobordisms of n -truss bundles are unique). An invertible n -truss bundle bordism is called an ‘ n -truss bundle isobordism’. Given two *unlabeled* n -truss bundles, if there is an isobordism between them, then there is a unique such isobordism; this uniqueness follows by iteratively applying Observation 2.1.98. However, for the same reasons as in Remark 2.2.72, this uniqueness does not hold in the labeled case. ---

Classification and totalization now provide an equivalence of categories, generalizing the previous Lemma 2.3.48 from n -trusses to n -truss bundles and the earlier Observation 2.2.73 from 1-truss bundles to n -truss bundles.

OBSERVATION 2.3.52 (Classification and totalization functors for labeled n -truss bundles). Given a poset B and a category \mathbf{C} , there is an equivalence of categories

$$\chi_- : n\mathbf{TBord}(B) //_{\mathbf{C}} \rightleftarrows \mathbf{Fun}(B, \mathbf{TBord}_{//_{\mathbf{C}}}^n) : \pi_-$$

specified as follows.

The ‘classification functor’ χ_- takes a \mathbf{C} -labeled n -truss bundle p to its classifying functor $\chi_p : B \rightarrow \mathbf{TBord}_{//_{\mathbf{C}}}^n$, and a \mathbf{C} -labeled n -truss bundle bordism $u : p \rightarrow q$ (by definition a labeled n -truss bundle over $B \times [1]$) to its classifying functor $\chi_u : B \times [1] \rightarrow \mathbf{TBord}_{//_{\mathbf{C}}}^n$ viewed as a natural transformation $\chi_u : \chi_p \Rightarrow \chi_q$.

The ‘totalization functor’ π_- takes a functor $F : B \rightarrow \mathbf{TBord}_{//_{\mathbf{C}}}^n$ to its total \mathbf{C} -labeled n -truss bundle π_F , and a natural transformation, represented as a functor $\mathbf{N} : B \times [1] \rightarrow \mathbf{TBord}_{//_{\mathbf{C}}}^n$, to its total labeled n -truss bundle $\pi_{\mathbf{N}}$, considered as a bundle bordism. —

REMARK 2.3.53 (Classifying categorical labeled n -truss bundles). Generalizing Remark 2.1.85, a ‘categorical n -truss bundle’ p over a category \mathbf{B} is a tower $\mathbf{T}_n \xrightarrow{p_n} \mathbf{T}_{n-1} \rightarrow \cdots \rightarrow \mathbf{T}_1 \xrightarrow{p_1} \mathbf{T}_0 = \mathbf{B}$ of categorical 1-truss bundles. A ‘categorical \mathbf{C} -labeled n -truss bundle’ p over a category \mathbf{B} is simply a categorical n -truss bundle \underline{p} over \mathbf{B} , together with a labeling functor $\text{lbl}_p : \mathbf{T}_n \rightarrow \mathbf{C}$. Generalizing Remark 2.2.74, the above classification and totalization constructions carry over to this categorical case, showing that \mathbf{C} -labeled n -truss bundles over a category \mathbf{B} (and their bundle bordisms) correspond to functors $\mathbf{B} \rightarrow \mathbf{TBord}_{//_{\mathbf{C}}}^n$ (and their natural transformations). —

2.3.2.3. Pullback, product, dualization, and suspension of n -truss bundles. Our usual constructions of pullbacks, duals, and suspensions carry over from 1-truss bundles to n -truss bundles. We also describe a notion of (non-commutative) products for n -trusses and n -truss bundles, based on the construction of pullbacks.

CONSTRUCTION 2.3.54 (Pullbacks of labeled n -truss bundles). Consider a \mathbf{C} -labeled n -truss bundle $p = (\underline{p}, \text{lbl}_p)$ over a poset B , with underlying bundle $\underline{p} = (p_n, p_{n-1}, \dots, p_1)$. Given a poset map $G : A \rightarrow B$, the pullback of the bundle p (along the map G) is the \mathbf{C} -labeled n -truss bundle $G^*p \equiv (\underline{G^*p}, \text{lbl}_{G^*p})$, with underlying bundle $\underline{G^*p} = (G^*p_n, G^*p_{n-1}, \dots, G^*p_1)$ and labeling functor lbl_{G^*p} constructed as follows.

- Define $\text{Tot}^0 G := G : A \rightarrow B$.
- Inductively with ascending i , define $G^*p_i : G^*T_i \rightarrow G^*T_{i-1}$ and $\text{Tot}^i G : G^*T_i \rightarrow T_i$ by the 1-truss bundle pullback of $p_i : T_i \rightarrow T_{i-1}$ along the poset map $\text{Tot}^{i-1} G : G^*T_{i-1} \rightarrow T_{i-1}$ (where G^*T_{i-1} is the total poset of G^*p_{i-1}).

› Finally, set the labeling functor lbl_{G^*p} to be the composite $\text{lbl}_p \circ \text{Tot}^n G$. —

We can display the pullback G^*p of the labeled n -truss bundle p , along the base poset map G , as the upper row in the following diagram:

$$\begin{array}{ccccccccccc}
 & & G^*T_n & \xrightarrow{G^*p_n} & G^*T_{n-1} & \xrightarrow{G^*p_{n-1}} & \cdots & \xrightarrow{G^*p_2} & G^*T_1 & \xrightarrow{G^*p_1} & A \\
 \text{C} & \swarrow \text{lbl}_{G^*p} & \downarrow \text{Tot}^n G & \lrcorner & \downarrow \text{Tot}^{n-1} G & \lrcorner & \cdots & \lrcorner & \downarrow \text{Tot}^1 G & \lrcorner & \downarrow \text{Tot}^0 G = G \\
 & \swarrow \text{lbl}_p & T_n & \xrightarrow{p_n} & T_{n-1} & \xrightarrow{p_{n-1}} & \cdots & \xrightarrow{p_2} & T_1 & \xrightarrow{p_1} & B
 \end{array}$$

Note that the poset maps $\text{Tot}^i G$ (together with the labeling category functor $\text{id} : \mathbb{C} \rightarrow \mathbb{C}$) assemble into a \mathbb{C} -labeled n -truss bundle map $G^*p \rightarrow p$, which we call the ‘pullback bundle map’. As before, when $G : A \hookrightarrow B$ is a subposet, the pullback recovers the earlier notion of restriction of labeled n -truss bundles, i.e. $G^*p = p|_A$.

As a special case of truss bundle pullbacks, we obtain the following truss products.

CONSTRUCTION 2.3.55 (Products of labeled n -trusses and n -truss bundles). Given a \mathbb{C} -labeled n -truss $T = (\underline{T}, \text{lbl}_T)$ and an unlabeled m -truss bundle $q = (q_m, q_{m-1}, \dots, q_1)$ over a poset S_0 , where $q_i : S_i \rightarrow S_{i-1}$; let $G : S_m \rightarrow [0]$ be the terminal map, let $(G^*\underline{T}, q)$ denote the tower of 1-truss bundles obtained by concatenating the tower $G^*\underline{T}$ with the tower q , and let $G^*\text{lbl}_T$ be shorthand for the composite $\text{lbl}_T \circ (G \times \text{id}_{T_n}) : S_m \times T_n \rightarrow \mathbb{C}$. We define the ‘truss product’ $q \times T$ to be the \mathbb{C} -labeled $(m+n)$ -truss bundle $((G^*\underline{T}, q), G^*\text{lbl}_T)$ over the poset S_0 . —

REMARK 2.3.56 (Non-commutativity of products). By omitting labelings, the preceding construction gives a notion of products of trusses. Note well that given an n -truss T and an m -truss S , the product $T \times S$ and the product $S \times T$ differ in general; that is, truss products are non-commutative. Some examples of this non-commutativity can be found in [Chapter C](#). —

Taking duals of the constituent 1-truss bundles provides a dualization of labeled n -truss bundles, as follows.

CONSTRUCTION 2.3.57 (Dualization of labeled n -truss bundles and their maps). Given a \mathbb{C} -labeled n -truss bundle $p = (\underline{p}, \text{lbl}_p)$ with underlying n -truss bundle $\underline{p} = (p_n, p_{n-1}, \dots, p_1)$, its dual is the \mathbb{C}^{op} -labeled n -truss bundle p^\dagger , whose underlying n -truss bundle is $\underline{p}^\dagger = (p_n^\dagger, p_{n-1}^\dagger, \dots, p_1^\dagger)$ (where p_i^\dagger is the dual of the 1-truss bundle p_i , see [Construction 2.1.107](#)), and whose labeling lbl_{p^\dagger} is the opposite labeling $(\text{lbl}_p)^{\text{op}}$.

Given a labeled n -truss bundle map $F : p \rightarrow q$, the dual bundle map $F^\dagger : p^\dagger \rightarrow q^\dagger$ has its underlying n -truss bundle map $\underline{F}^\dagger = \underline{F}^\dagger$ given by the same maps of sets as the bundle map \underline{F} itself, and has relabeling functor $\text{lbl}_{F^\dagger} := (\text{lbl}_F)^{\text{op}}$.

We thus have a covariant involutive functor of labeled n -truss bundles:

$$\dagger : \text{LblTrsBun}_n \cong \text{LblTrsBun}_n. \quad \text{—}$$

CONSTRUCTION 2.3.58 (Dualization of labeled n -truss bundles and their bordisms). For a \mathbf{C} -labeled n -truss bundle bordism $u : p \rightarrow q$, given as a labeled bundle u over $B \times [1]$, its dual \mathbf{C}^{op} -labeled n -truss bundle bordism $u^\dagger : q^\dagger \rightarrow p^\dagger$ is provided by the dual labeled bundle u^\dagger (over $(B \times [1])^{\text{op}} \cong B^{\text{op}} \times [1]$) of the given labeled bundle u (over $B \times [1]$).

Dualization therefore gives an involutive isomorphism of labeled n -truss bundles and their bordisms:

$$\dagger : n\text{TBord}(B)_{//\mathbf{C}} \cong (n\text{TBord}(B^{\text{op}})_{//\mathbf{C}^{\text{op}}})^{\text{op}}.$$

When the base poset is trivial, this specializes, using the equivalence $n\text{TBord}_{//\mathbf{C}} \simeq \text{TBord}_{//\mathbf{C}}^n$ from Lemma 2.3.48, to an involutive isomorphism:

$$\dagger : \text{TBord}_{//\mathbf{C}}^n \cong (\text{TBord}_{//\mathbf{C}^{\text{op}}}^n)^{\text{op}}. \quad \text{—}$$

REMARK 2.3.59 (Duality of closed and open trusses). The dualization of Construction 2.3.57 sends closed n -truss bundles to open n -truss bundles, and singular n -truss bundle maps to regular n -truss bundle maps. Thus, in particular, dualization of n -truss bundles and their maps specializes to a covariant involutive isomorphism

$$\dagger : \bar{\text{Tr}}_n(B) \rightleftharpoons \overset{\circ}{\text{Tr}}_n(B^{\text{op}}) : \dagger$$

between the category of closed n -truss bundles with singular maps $\bar{\text{Tr}}_n(B)$, over the base poset B , and the category of open n -truss bundles with regular maps $\overset{\circ}{\text{Tr}}_n(B^{\text{op}})$, over the opposite base poset (see Notation 2.3.38). Of course, when the base poset is trivial, this specializes to the dualization case of most fundamental concern, between closed trusses and open trusses:

$$\dagger : \bar{\text{Tr}}_n \rightleftharpoons \overset{\circ}{\text{Tr}}_n : \dagger \quad \text{—}$$

Finally, straightforwardly generalizing the 1-truss bundle case, we mention suspensions of n -truss bundles.

CONSTRUCTION 2.3.60 (Suspension of n -truss bundles). For an (unlabeled) n -truss bundle $p = (p_n, p_{n-1}, \dots, p_1)$, its suspension is the n -truss bundle $\Sigma p = (\Sigma p_n, \Sigma p_{n-1}, \dots, \Sigma p_1)$, where Σp_i is the suspension bundle of the 1-truss bundle p_i , see Construction 2.1.111.

When the category \mathbf{C} has both initial and terminal objects, a \mathbf{C} -labeled n -truss bundle $p = (\underline{p}, \text{lbl}_p)$ has a suspension $\Sigma p = (\underline{\Sigma p}, \text{lbl}_{\Sigma p})$ with underlying bundle the suspension Σp of the underlying n -truss bundle, and with labeling functor $\text{lbl}_{\Sigma p} : \Sigma T_n \rightarrow \bar{\mathbf{C}}$ being simply lbl_p on $T_n \subset \Sigma T_n$ and sending the initial and terminal objects of the suspension to the initial and terminal objects of the labeling category, see Remark 2.2.81. —

2.3.3. n -Truss blocks and block sets. One of the most classical starting points for combinatorial topology is to consider the category Δ of combinatorial simplices; the presheaves on Δ are the *simplicial sets*. Though fundamental, there is nothing exclusive about simplices as a collection of basic shapes, and instead one may consider, for instance, the category \mathbb{G} of combinatorial globes or the category \square of combinatorial cubes; the presheaves on \mathbb{G} are the *globular sets*, and the presheaves on \square are the *cubical sets*.

The theory of trusses provides a new collection of combinatorial basic shapes, namely the *truss blocks*. Truss blocks are by definition the trusses with an initial element, and they assemble into a combinatorially defined category \mathbb{X} ; presheaves on \mathbb{X} are the *block sets*. Truss blocks simultaneously generalize combinatorial simplices, combinatorial globes, and combinatorial cubes and therefore inherit some of the merits and potentialities of each classical context. More importantly, they are the component building blocks of trusses themselves, and therefore basic for the theory of framed combinatorial topology as such.

SYNOPSIS. We discuss face, degeneracy, embedding, and coarsening maps of trusses, and show that a singular map of closed trusses uniquely factors into a degeneracy and a face, and that a regular map of open trusses uniquely factors into a coarsening and an embedding. We then define truss blocks as closed trusses with an initial element, and introduce the category of blocks and their singular maps. Next we define block sets as presheaves on the category of blocks, and block complexes as presheaves on the category of blocks with just their face maps. Finally, we briefly describe the dual story of truss braces, that is open trusses with a terminal element, the resulting category of braces and their regular maps, and the consequent notion of brace sets.

2.3.3.1. Factorization of truss maps. The classical category $\Delta_{\leq n}$ of combinatorial simplices of dimension at most n (like the category of all combinatorial simplices) has two distinguished classes of maps, namely the injective monotone maps, called face maps, and the surjective monotone maps, called degeneracy maps; the category has the fundamental geometric property that any map factors uniquely as a degeneracy followed by a face map. The category $\bar{\text{Tr}}_n$ of closed n -trusses and singular maps similarly has two distinguished classes of maps, *faces* and *degeneracies*, and a corresponding unique factorization property. Moreover, the dual category $\overset{\circ}{\text{Tr}}_n$ of open n -trusses and regular maps also has dual distinguished classes of maps, called *embeddings* and *coarsenings*, and a respective factorization property.

We now introduce the various relevant classes of truss maps.

TERMINOLOGY 2.3.61 (Subtrusses, faces, and embeddings of 1-trusses). A map of 1-trusses $F : T \rightarrow S$ is called an ‘injection’ if it is injective on objects.

> An injection $F : T \rightarrow S$ is a ‘subtruss’ map if it is balanced.

- › An injection $F : T \rightarrow S$ is a ‘face’ map if T and S are closed and the map is singular. (We also refer to these as ‘closed face’ maps for emphasis.)
- › An injection $F : T \rightarrow S$ is an ‘embedding’ map if T and S are open and the map is regular. (We also refer to these as ‘open embedding’ maps for emphasis.) —

OBSERVATION 2.3.62 (Characterizing faces and embeddings). Note that a closed face map is necessarily balanced, and an open embedding map is also necessarily balanced. Thus closed faces are exactly the closed subtrusses of closed 1-trusses, and open embeddings are exactly the open subtrusses of open 1-trusses. —

Recall, for use in the following terminology for surjective truss maps, that the endpoint type of a truss refers to the dimensions of the (frame order) minimal and maximal elements; see [Terminology 2.1.23](#). Note that a surjective map of 1-trusses preserves endpoints, and so if the trusses have the same endpoint type then the map preserves the dimensions of the endpoints.

TERMINOLOGY 2.3.63 (Degeneracies and coarsenings of 1-trusses). A map of 1-trusses $F : T \rightarrow S$ is called a ‘surjection’ if it is surjective on objects.

- › A surjection $F : T \rightarrow S$ is a ‘degeneracy’ map if T and S have the same endpoint type and the map is singular. If furthermore T and S are closed, the map is a ‘closed degeneracy’.
- › A surjection $F : T \rightarrow S$ is a ‘coarsening’ map if T and S have the same endpoint type and the map is regular. If furthermore T and S are open, the map is an ‘open coarsening’. —

Note that if a surjective map of 1-trusses is balanced, then it must be an isomorphism; so there is no new notion of surjective maps corresponding to the notion of subtrusses in the injective map case.

EXAMPLE 2.3.64 (Faces, embeddings, degeneracies, and coarsenings of 1-trusses). In [Figure 2.48](#) we depict an example of each of the aforementioned types of maps of 1-trusses. —

The preceding terminology for 1-truss maps carries over to the case of n -trusses (and labeled n -trusses and more generally bundles) as follows.

TERMINOLOGY 2.3.65 (Faces, embeddings, degeneracies, and coarsenings of n -trusses). Given n -trusses $T = (p_n, p_{n-1}, \dots, p_1)$ and $S = (q_n, q_{n-1}, \dots, q_1)$, an n -truss map $F : T \rightarrow S$ is called an ‘injection’ if each 1-truss bundle map $F_i : p_i \rightarrow q_i$ has every one of its fibers being a 1-truss injection. Similarly, the n -truss map $F : T \rightarrow S$ is called a ‘subtruss’, ‘face’, ‘embedding’, ‘surjection’, ‘degeneracy’, ‘closed degeneracy’, ‘coarsening’, or ‘open coarsening’ exactly when each 1-truss bundle map F_i is fiberwise of the corresponding designation.

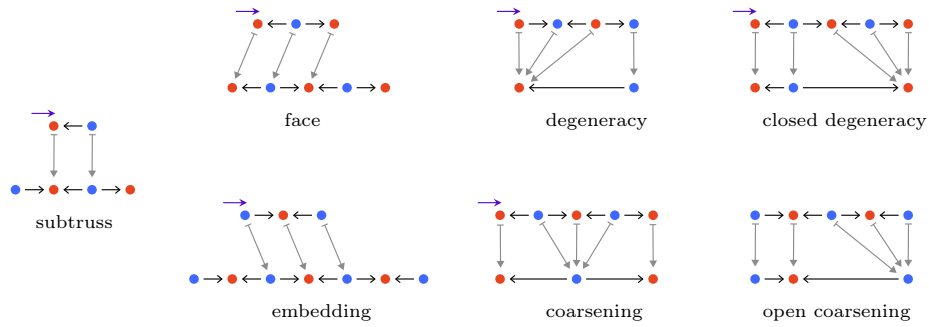

FIGURE 2.48. Faces, embeddings, degeneracies, and coarsenings.

The same terms apply, again by simply requiring the condition on every fiber at every stage, to n -truss bundles maps and further to labeled n -truss bundle maps, without further conditions²⁴ on the given base map. \square

NOTATION 2.3.66 (Categories of degeneracies and coarsenings). The category of n -trusses and their degeneracies is denoted $\text{Trs}_n^{\text{deg}}$. Similarly the category of n -trusses and their coarsenings is denoted $\text{Trs}_n^{\text{crs}}$. \square

TERMINOLOGY 2.3.67 (Coarsenings versus refinements). Given a coarsening map of n -trusses $F : T \rightarrow S$, which grammatically we consider as ‘coarsening T to S ’, we also call the map a ‘refinement’, and grammatically consider it as ‘refining S to (or by) T ’. That is, we use the terms ‘coarsening’ and ‘refinement’ for the same structure but seen from converse perspectives—a coarsening coarsens the domain to the codomain, while a refinement refines the codomain to the domain. \square

Equipped with the notions of face and degeneracy maps, and dually embedding and coarsening maps, we find that both singular maps of closed trusses, and regular maps of open trusses, admit a canonical factorization into an epimorphism and a monomorphism; that is, both the categories $\overline{\text{Trs}}_n$ and $\dot{\text{Trs}}_n$ have an epi–mono factorization property, as follows.

LEMMA 2.3.68 (Epi–mono factorization for closed singular and open regular maps). *Any singular map F of closed n -trusses factors uniquely into a degeneracy F^{E} followed by a face F^{M} . Similarly, any regular map F of open n -trusses factors uniquely into a coarsening F^{E} followed by an embedding F^{M} .*

²⁴In fact, when considering posets that are fundamental posets of cellular or cellable stratifications, it does make sense to enforce corresponding designations on the base map as well (i.e. requiring the map to be the fundamental poset map of a stratified topological ‘face’ map, ‘degeneracy’ map, open stratified ‘embedding’, or stratified ‘coarsening’). For most of our later constructions, this remark will apply.

PROOF. In both cases the factorization $F = F^M F^E$ is given simply by factoring the i th stage face poset maps $F_i = F_i^M F_i^E$ using the standard epi-mono factorization in the category \mathbf{Pos} of posets. \square

EXAMPLE 2.3.69 (Epi-mono factorization of closed singular truss maps). In Figure 2.49 we depict a singular map $F : T \rightarrow S$ of closed 2-trusses, together with its epi-mono factorization $F = F^M \circ F^E$. \square

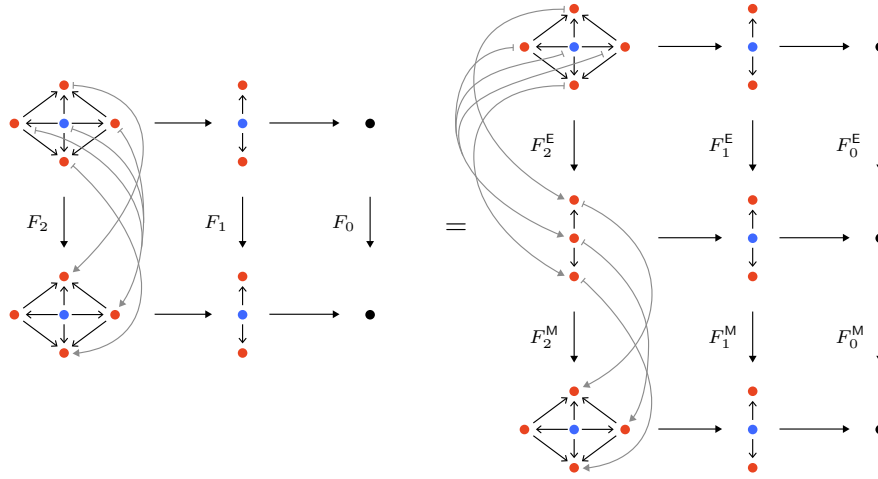

FIGURE 2.49. Epi-mono factorization of a closed singular 2-truss map.

EXAMPLE 2.3.70 (Failure of epi-mono factorization for general truss maps). In Figure 2.50, we depict a map $F : T \rightarrow S$ of 2-trusses (neither a closed singular nor an open regular map), which cannot be factored into an epimorphism followed by a monomorphism. \square

The epi-mono factorization property of the category of closed trusses and their singular maps, and similarly of the category of open trusses and their regular maps, provides a rigid formal structure to the morphisms of these categories. The natural transformations of these categories are even more constrained, in that there are no non-identity natural transformations whatsoever; thus the hom posets (consisting of maps and their natural transformations) are in fact discrete.

LEMMA 2.3.71 (Rigidity of natural transformations for 1-trusses). Consider 1-trusses T and S , and 1-truss maps $E, F : T \rightarrow S$. Assume one of the following holds:

- > T and S are open, and E and F are regular (for instance embeddings),
- > T and S are closed, and E and F are singular (for instance faces),
- > E and F are coarsenings, or
- > E and F are degeneracies, or

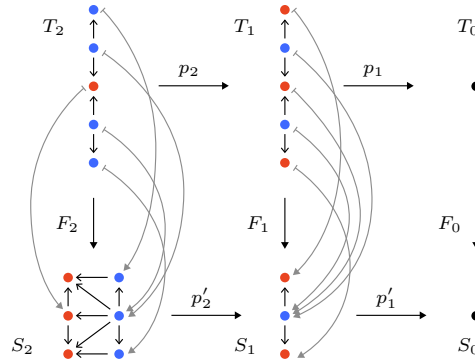

FIGURE 2.50. Failure of epi-mono factorization of a 2-truss map.

> E and F are balanced.

Then any natural transformation $\nu : E \Rightarrow F : (T, \trianglelefteq) \rightarrow (S, \trianglelefteq)$ must be the identity.

PROOF. We discuss the case of open 1-trusses and regular maps. (The closed singular case follows by duality, and the other cases follow by similar arguments.) The maps E and F send a regular value $a \in T$ to regular values $E(a) \in S$ and $F(a) \in S$; because there are no non-identity arrows between regular values in S , we must have $E(a) = F(a)$. Because T is open, a singular value $b \in T$ has two adjacent regular values $b \pm 1$, which are sent to $E(b \pm 1) = F(b \pm 1)$. Since the maps E and F are functorial and monotone, both $E(b)$ and $F(b)$ must be the unique element $y \in S$ such that $E(b - 1) = F(b - 1) \trianglelefteq y \triangleright E(b + 1) = F(b + 1)$, and thus $E(b) = F(b)$. The functors E and F are thus identical and the natural transformation ν is necessarily trivial. \square

LEMMA 2.3.72 (Rigidity of natural transformations for n -trusses). Consider n -trusses T and S , and n -truss maps $E, F : T \rightarrow S$. Assume one of the following holds:

- > T and S are open and E and F are regular (for instance embeddings),
- > T and S are closed and E and F are singular (for instance faces)
- > E and F are coarsenings, or
- > E and F are degeneracies, or
- > E and F are balanced.

Then any natural transformation $\nu : E_n \Rightarrow F_n$ of total poset maps $E_n, F_n : (T_n, \trianglelefteq) \rightarrow (S_n, \trianglelefteq)$ must be the identity.

All natural transformations are identities also in the corresponding cases of base-preserving n -truss bundle maps, namely open bundles and regular maps, closed bundles and singular maps, coarsenings of bundles, or degeneracies of bundles.

PROOF. We discuss the case of open n -trusses and regular maps. (The case of closed n -trusses and singular maps follows by duality, and the other cases follow by similar arguments.) Let $T = (p_n, p_{n-1}, \dots, p_1)$ and $S = (q_n, q_{n-1}, \dots, q_1)$ be the constituent 1-truss bundles. Arguing inductively, assume the statement holds for $(n - 1)$ -trusses; the base case of 1-trusses was shown in the previous lemma. Postcomposing the natural transformation ν with the bundle projection q_n yields a natural transformation $q_n \circ \nu : q_n \circ E_n \Rightarrow q_n \circ F_n$, which may equivalently be considered a natural transformation $E_{n-1} \circ p_n \Rightarrow F_{n-1} \circ p_n$. We must have $q_n \circ \nu = \nu_{n-1} \circ p_n$ for some natural transformation $\nu_{n-1} : E_{n-1} \Rightarrow F_{n-1}$. (In general, given poset maps $E, F : B \rightarrow C$ and $G : A \rightarrow B$, any natural transformation $\nu : E \circ G \Rightarrow F \circ G$ will be of the form $\mu \circ G$ for some natural transformation $\mu : E \Rightarrow F$.) By the inductive assumption we know that $\nu_{n-1} = \text{id}$. Finally, by applying the rigidity of 1-trusses (from the previous lemma) to the transformation ν , restricted to the fibers of p_n and q_n , we find that ν is itself trivial, as required.

The case of base-preserving n -truss bundle maps follows by applying the same argument to each n -truss fiber of the bundle. \square

2.3.3.2. The definition of truss blocks. Any closed truss may be considered as being built by piecing together certain elementary combinatorial building blocks, called straightforwardly *truss blocks* or simply *blocks*. A truss block is a closed truss with an initial element; the existence of an initial element ensures these blocks serve as component combinatorial cells.

DEFINITION 2.3.73 (Truss blocks). An n -**truss block** T is a closed n -truss T whose total poset (T_n, \trianglelefteq) has an initial element \perp . It is more specifically an n -**truss m -block** if the initial element has depth m . —

Recall that the depth of an element in a poset is the maximal length of a chain starting at that element.

EXAMPLE 2.3.74 (Truss blocks). In Figure 2.51 we depict a 2-truss 2-block on the left, together with its (informal) geometric realization on the right. In contrast to our earlier example of a general closed 2-truss in Figure 2.42, note that the realization of this 2-truss 2-block consists of a single 2-cell. In Figure 2.52 we similarly depict a 3-truss 3-block and its realization. A plethora of further truss blocks and their realizations can be found in Chapter C. —

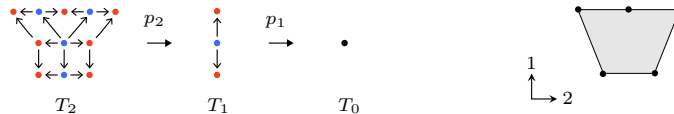

FIGURE 2.51. A 2-truss 2-block and its corresponding framed 2-cell.

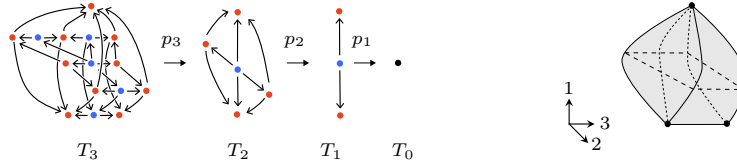

FIGURE 2.52. A 3-truss 3-block and its corresponding framed 3-cell.

REMARK 2.3.75 (Blocks truncate). Given an n -truss block $T = (p_n, p_{n-1}, \dots, p_1)$, the truncation $T_{\leq i} = (p_i, p_{i-1}, \dots, p_1)$ is an i -truss block; indeed, the initial element in the total poset T_n of the n -truss T projects by the map $p_{>i} = p_{i+1} \circ p_{i+2} \circ \dots \circ p_n$ to an initial element in the total poset T_i of the i -truss $T_{\leq i}$. —

REMARK 2.3.76 (Blocks stabilize). Given an n -truss block $T = (p_n, p_{n-1}, \dots, p_1)$, there is an associated $(n + i)$ -truss block $T_{+i} = (\text{id}, \dots, \text{id}, p_n, p_{n-1}, \dots, p_1)$, whose first i 1-truss bundles are identities with singular fibers. —

OBSERVATION 2.3.77 (Dimensions of blocks). Given an n -truss m -block $T = (p_n, p_{n-1}, \dots, p_1)$, the block depth m is computed by

$$m = \sum_{i=1}^n \dim(p_{>i}(\perp)) \quad .$$

Here, in the i th summand, \dim is the dimension functor of the 1-truss bundle p_i . In other words, the depth m is the count of the number of bundles p_i that are non-trivial (i.e. whose underlying poset map is not the identity map). In particular, when $m < n$, at least one bundle p_i must be trivial. Note further that the depth m corresponds to the geometric dimension of the realization of the m -block. —

NOTATION 2.3.78 (Categories of n -blocks). The category of n -truss blocks, denoted Blk_n , is the full subcategory, of the category $\overline{\text{Trs}}_n$ of closed trusses and singular maps, whose objects are n -truss blocks. —

NOTATION 2.3.79 (The category of blocks). The category of blocks, denoted \mathbb{X} , is the colimit under stabilization of the categories Blk_n of n -truss blocks. —

REMARK 2.3.80 (The notation for the category of blocks). The reader who flipped ahead to Appendix Figure C.1 to see more 2-dimensional blocks, will have recognized some cell structures familiar from other shape categories, such as the 2-globe (the unique 2-dimensional shape in the globular category \mathbb{G}), the 2-simplex (the unique 2-dimensional shape in the simplicial category Δ), and the 2-cube (the unique 2-dimensional shape in the cubical category \square), along with some less standard 2-cell decompositions. The last block in

that figure has two 1-cells on both its upper and lower boundaries, and is therefore unequivocally beyond the realm of globular, simplicial, cubical, or opetopic models for higher-categorical structures. We take this shape as informally characteristic and let its X configuration of regular values inspire the notation \mathbb{X} for the category of blocks. —

Recall from Terminologies 2.3.61 and 2.3.65 and Observation 2.3.62 that faces of closed trusses are the closed subtrusses. There are distinguished faces, namely those that are blocks, constructed as closures of elements of closed trusses, as follows.

CONSTRUCTION 2.3.81 (Face blocks in closed trusses). Let $T = (p_n, p_{n-1}, \dots, p_1)$ be a closed n -truss, and consider an element $x \in T_n$ in the total poset. We construct a subtruss inclusion $T^{\triangleright x} \hookrightarrow T$ such that $T^{\triangleright x} = (p_n^{\triangleright x}, p_{n-1}^{\triangleright x}, \dots, p_1^{\triangleright x})$ is a block, called the ‘face block’ of the element x .

For each $i \leq n$, denote by $x_i := p_{>i}x$ the image of the element x under the composite projection $p_{>i} = p_{i+1} \circ \dots \circ p_n : T_n \rightarrow T_i$. Set $(T_i^{\triangleright x}, \trianglelefteq)$ to be the subposet of (T_i, \trianglelefteq) given by the upper closure of the element x_i in (T_i, \trianglelefteq) . Set the 1-truss bundle projection $p_i^{\triangleright x} : T_i^{\triangleright x} \rightarrow T_{i-1}^{\triangleright x}$ to be the restriction of $p_i : T_i \rightarrow T_{i-1}$ to the upper closure subposets. Altogether these bundles and their inclusions $p_i^{\triangleright x} \hookrightarrow p_i$ form the components of the desired subtruss $T^{\triangleright x} \hookrightarrow T$. Note that $T^{\triangleright x}$ is an m -block, where m is the depth of the element x in the total poset T_n . —

EXAMPLE 2.3.82 (Face blocks in closed trusses). In Figure 2.53, on the left we depict a 2-truss $T_2 \rightarrow T_1 \rightarrow T_0$, and highlight three of its face blocks. The total poset T_2 is the fundamental poset of the cell complex on the right; note that face blocks (obtained by taking ‘upper closures’ in the total poset) correspond to closed cells in the cell complex (obtained by taking ‘topological closure’ in the complex). —

REMARK 2.3.83 (All subtruss blocks are face blocks). Given an n -truss T , the subtrusses of T that are n -truss blocks are in bijective correspondence with the elements of the total poset T_n . Indeed, every such subtruss block of T determines an element of T_n , namely the image of the initial element of the block, and conversely elements of T_n determine face blocks by taking upper closures as in Construction 2.3.81. —

2.3.3.3. Block sets and block complexes. Simplicial sets are presheaves on the category of combinatorial simplices. We have corresponding notions of presheaves on the category of n -truss blocks, or more generally all blocks, as follows.

DEFINITION 2.3.84 (n -Truss block sets). An n -truss **block set** is a **Set**-valued presheaf on the category \mathbf{Blk}_n of n -truss blocks. —

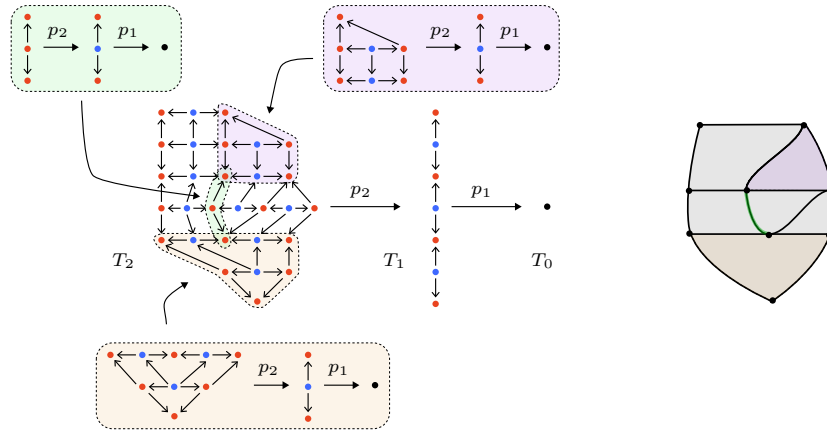

FIGURE 2.53. Face blocks in a 2-truss.

NOTATION 2.3.85 (Category of n -truss block sets). The ‘category of n -truss block sets’, i.e. the category of **Set**-valued presheaves on the category \mathbf{Blk}_n of n -truss blocks, will be denoted \mathbf{BlkSet}_n . —

DEFINITION 2.3.86 (Block sets). A **block set** is a **Set**-valued presheaf on the category \mathbb{X} of blocks. —

NOTATION 2.3.87 (Category of block sets). The ‘category of block sets’, i.e. the category of **Set**-valued presheaves on the category \mathbb{X} of blocks, will be denoted $\widehat{\mathbb{X}}$. —

We usually abbreviate ‘ n -truss block set’ simply to ‘block set’, leaving the dimension n implicit and eliding the difference between presheaves on \mathbf{Blk}_n for some fixed finite n and presheaves on the colimit category \mathbb{X} (which includes all the categories \mathbf{Blk}_n at once). In the subsequent discussion, we restrict attention to n -truss block sets, for fixed n , but everything can be extended to block sets, that is to the context of variable n .

TERMINOLOGY 2.3.88 (Faces and degeneracies in block sets). For a block set $X \in \mathbf{BlkSet}_n$ and a block $B \in \mathbf{Blk}_n$, we refer to elements of the set $X(B)$ as ‘blocks of shape B ’ in the block set X . For a given block $b \in X(B)$ of shape B in the block set X , we may take face map or degeneracy maps of the block, as follows.

- ▷ For a specific face map $F : C \rightarrow B$ in \mathbf{Blk}_n , we call $c := (X(F))(b) \in X(C)$ the ‘ F -face’ of the block $b \in X(B)$.
- ▷ For a specific degeneracy map $F : C \rightarrow B$ in \mathbf{Blk}_n , we call $c := (X(F))(b) \in X(C)$ the ‘ F -degeneracy’ of the block $b \in X(B)$. —

TERMINOLOGY 2.3.89 (Nondegenerate blocks). A block $c \in X(C)$ (of shape C in the block set X) is a ‘nondegenerate block’ if it is not an F -degeneracy for any non-identity degeneracy map F . —

Recall that semi-simplicial sets, also known as Δ -complexes [Hat02], are simplicial sets ‘without degeneracy maps’. We have an analogous notion of block complexes as block sets ‘without degeneracy maps’, as follows.

DEFINITION 2.3.90 (n -Truss block complex). An n -**truss block complex** is a **Set**-valued presheaf on the injective subcategory $\mathbf{Blk}_n^{\text{inj}} \subset \mathbf{Blk}_n$, i.e. on the wide subcategory containing only face maps. \square

Of course one may define a ‘block complex’ (without fixing n) as a presheaf on the injective subcategory of the category of blocks. We typically abbreviate ‘ n -truss block complex’ to simply ‘block complex’.

Recall that a CW-complex is regular when each of its closed cells embeds into the whole complex. Similarly a Δ -complex may be called regular when each of its closed simplices embeds into the complex; concretely, that occurs when all the faces of any given simplex are distinct. Analogously, a regular block complex is one for which all the faces of any given block are distinct, as follows.

DEFINITION 2.3.91 (Regular block complexes). A block complex X is called **regular** when, for every block $b \in X(B)$ of shape B , and every block shape C , all the faces $(X(F))(b) \in X(C)$, for face maps $F : C \rightarrow B$, are distinct. \square

NOTATION 2.3.92 (Categories of block complexes). The ‘category of block complexes’, i.e. the category of presheaves on the injective subcategory $\mathbf{Blk}_n^{\text{inj}}$ of n -truss blocks, will be denoted $\mathbf{BlkCplx}_n$. Its full subcategory of regular block complexes will be denoted $\mathbf{RBlkCplx}_n$. \square

The next example illustrates the differences between the notions of block set, block complex, and regular block complex: in a regular block complex, all the faces of each block are distinct; in a general block complex, a block may have more than one face coincident; in a block set, a face of a block may be a nontrivial degeneracy of another block.

EXAMPLE 2.3.93 (A block set, a block complex, and a regular block complex). In Figure 2.54, we depict the nondegenerate blocks of a 2-truss block set (on the left) and of a 2-truss block complex (on the right). In each case, we bubble and color-code the individual nondegenerate blocks; we then use the color coding to indicate the face-block relationships. Note that in the block set, the left and right 1-faces of the 2-block are a nontrivial degeneracy of the 0-block (and are bubbled in purple accordingly); the existence of these degenerate blocks prevents this block set from being a block complex. By contrast, in the (nonregular) block complex, the left and right 1-faces of the 2-block are both the red-bubbled nondegenerate 1-block.

In Figure 2.55, we illustrate a regular block complex, by depicting its three 2-truss 2-blocks and the identifications of their face 1-blocks. Specifically, each of the three distinct gray-bubbled 1-blocks is shared between two 2-blocks, as indicated by the given geometric arrangement. The remaining 1-blocks are

pairwise identified according to the bubble colors. Altogether, this regular complex has six 0-blocks (not indicated), nine 1-blocks, and three 2-blocks. Note the truss poset towers of all the blocks can be inferred, by projection, from the given total posets and the purple frame arrows. —

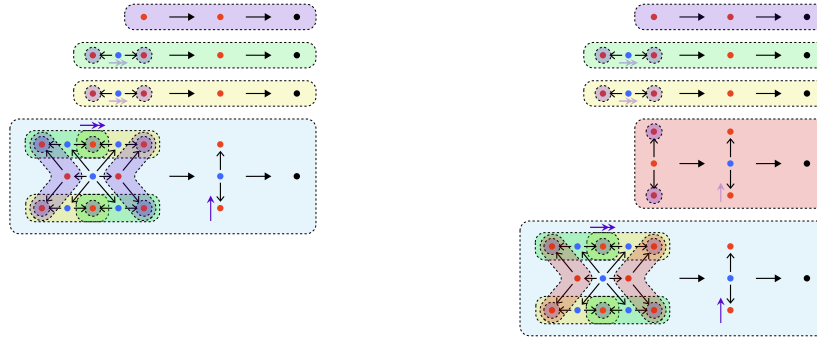

FIGURE 2.54. The blocks of a block set and of a block complex.

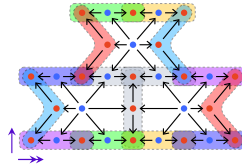

FIGURE 2.55. A regular block complex.

We end this discussion of block sets with a few technical observations about the categorical relationship of blocks, trusses, their maps, and their presheaves. (Readers may skip ahead to Section 2.3.3.4 without consequence.)

CONSTRUCTION 2.3.94 (Block nerve of trusses). Given a closed n -truss T , its ‘block nerve’ is the block set $\bar{\text{Tr}}_n(-, T)$ sending a block B to the hom-set $\bar{\text{Tr}}_n(B, T)$. This construction is functorial and gives rise to the ‘block nerve functor’ $N_{\text{Blk}} : \bar{\text{Tr}}_n \rightarrow \text{BlkSet}_n$. —

REMARK 2.3.95 (Building trusses from their blocks). We can now make precise the sense in which a closed n -truss can be built from its blocks. Given a closed n -truss $T \in \bar{\text{Tr}}_n$, denote by Blk_n/T the comma category of the inclusion $\text{Blk}_n \hookrightarrow \bar{\text{Tr}}_n$ (that is, objects of Blk_n/T are singular maps $B \rightarrow T$ from blocks to T , and morphisms are block maps $B \rightarrow B'$ commuting with the given maps to T). The truss T is now given by the colimit

$$T = \text{colim}(\text{Blk}_n/T \rightarrow \bar{\text{Tr}}_n)$$

of the forgetful functor $\text{Blk}_n/T \rightarrow \bar{\text{Tr}}_n$ mapping $(B \rightarrow T)$ to the block B . (The colimit may also be taken to have source the smaller category with

objects the face maps from blocks to the truss T , and with morphisms the commuting face maps of blocks.) \square

The above remark is equivalent to the statement that the functor $\mathbf{Blk}_n \hookrightarrow \bar{\mathbf{Tr}}_n$ is dense, and also to the statement that the nerve functor $N_{\mathbf{Blk}}$ is fully faithful.

REMARK 2.3.96 (Block complexes and regularity in block sets). Restricting presheaves along the inclusion $j : \mathbf{Blk}_n^{\text{inj}} \hookrightarrow \mathbf{Blk}_n$ provides the pullback functor $j^* : \mathbf{BlkSet}_n \rightarrow \mathbf{BlkCplx}_n$ from block sets to block complexes. That functor has left adjoint $j_!$ and right adjoint $j^!$ given by left and right Kan extension respectively [Rie14]. The left adjoint $j_!$ can be thought of as ‘freely adjoining degeneracies’ to a given block complex.

We say that a block set ‘is a block complex’ if it lies in the essential image of this free adjunction $j_!$, and we say it ‘is regular’ if it lies in the essential image of the free adjunction $j_!$ restricted to regular block complexes. \square

OBSERVATION 2.3.97 (Block nerves are regular). For any closed n -truss T , its block nerve $N_{\mathbf{Blk}}T$ is regular. Indeed, any map $B \rightarrow T$ from a block B to the truss T factors uniquely into a degeneracy map followed by a face map (see Lemma 2.3.68). Truss face maps are injective on blocks. It follows that $N_{\mathbf{Blk}}T \cong j_! \bar{\mathbf{Tr}}_n(i-, T)$ for $i : \mathbf{Blk}_n^{\text{inj}} \hookrightarrow \bar{\mathbf{Tr}}_n$, and that $\bar{\mathbf{Tr}}_n(i-, T)$ is regular, as needed. \square

Degenerate blocks in block sets can have a rather different character than degenerate simplices in simplices sets, as highlighted by the following final two remarks.

REMARK 2.3.98 (Interior versus boundary degeneracies). Degeneracies of blocks may be separated into two distinct classes:

- › A degeneracy map $F : C \rightarrow B$ is a ‘boundary degeneracy’ if the blocks C and B are of the same dimension.
- › A degeneracy map $F : C \rightarrow B$ is an ‘interior degeneracy’ if the dimension of the block C is strictly greater than the dimension of the block B .

The second sort of degeneracy is familiar from simplicial sets. Due to the existence of degeneracies of the first sort, a block in a block set may be degenerate in a way that is only visible on its boundary. \square

REMARK 2.3.99 (Block sets are not Eilenberg–Zilber). The Eilenberg–Zilber lemma [EZ50] states that every simplex in a simplicial set is a degeneracy of a unique nondegenerate simplex. The analogous property fails for block sets that do not satisfy further sheaf conditions. \square

2.3.3.4. Truss braces and brace sets. Recall that closed n -trusses and open n -trusses are related by covariant involutive duality isomorphisms $\dagger : \bar{\mathbf{Tr}}_n \cong \check{\mathbf{Tr}}_n : \dagger$, which reverse the face orders and interchange the role of singular and regular elements and maps. The whole story of truss blocks and block sets may be transported across this duality, to provide a corresponding story of *truss braces* and *brace sets*. For convenience, we briefly record the most central aspects of that dual story.

DEFINITION 2.3.100 (Truss braces). An *n*-truss brace T is an open *n*-truss whose total poset (T_n, \leq) has a terminal element \top . It is more specifically an *n*-truss *m*-brace if the terminal element has height $(n - m)$. —

Recall the height of an element in a poset is the maximal length of a chain ending at that element.

EXAMPLE 2.3.101 (A truss brace). In Figure 2.56 we depict a 2-truss 0-brace on the left, obtained by dualizing the 2-truss 2-block from Figure 2.51. We depict on the right an (informal) geometric realization of that brace; notice that this realization is geometrically dual to the cell realizing the dual truss block. (Such realizations will be formalized later on using the notion of ‘meshes’.) —

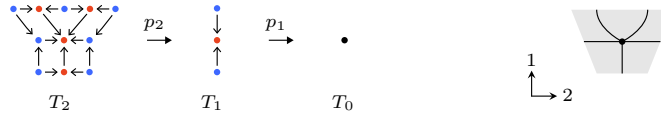

FIGURE 2.56. A 2-truss 0-brace.

REMARK 2.3.102 (Braces stabilize). Given an *n*-truss brace $T = (p_n, p_{n-1}, \dots, p_1)$, there is an associated $(n + i)$ -truss brace $T^{+i} = (\text{id}, \dots, \text{id}, p_n, p_{n-1}, \dots, p_1)$, whose first *i* 1-truss bundles are identities with regular fibers. —

OBSERVATION 2.3.103 (Dimensions of braces). Given an *n*-truss *m*-brace $T = (p_n, p_{n-1}, \dots, p_1)$, the brace dual height *m* is computed by

$$m = \sum_{i=1}^n \dim(p_{>i}(\top))$$

In particular, when $m < n$, at least one bundle p_i must be trivial. —

Dual to ‘face blocks’ we have a notion of ‘embedding braces’ as follows.

CONSTRUCTION 2.3.104 (Embedding braces in open trusses). Let T be an open *n*-truss, and consider an element $x \in T_n$ in the total poset. There is a subtruss $T^{\leq x} \hookrightarrow T$, called the ‘embedding brace’ of the element x , given as the unique open subtruss of T that is a brace whose terminal element maps to x . —

NOTATION 2.3.105 (Category of *n*-truss braces). The category of *n*-truss braces, denoted \mathbf{Brc}_n , is the full subcategory, of the category \mathbf{Tr}_n of open trusses and regular maps, whose objects are *n*-truss braces. —

NOTATION 2.3.106 (The category of braces). The category of braces, denoted \mathbb{X} , is the colimit under stabilization of the categories \mathbf{Brc}_n of *n*-truss braces. —

DEFINITION 2.3.107 (n -Truss brace sets). An n -truss brace set is a \mathbf{Set} -valued presheaf on the category \mathbf{Brc}_n of n -truss braces. \square

NOTATION 2.3.108 (Category of n -truss brace sets). The ‘category of n -truss brace sets’, i.e. the category of \mathbf{Set} -valued presheaves on the category \mathbf{Brc}_n of n -truss braces, will be denoted \mathbf{BrcSet}_n . \square

DEFINITION 2.3.109 (Brace sets). A brace set is a \mathbf{Set} -valued presheaf on the category \mathbb{X} of braces. \square

NOTATION 2.3.110 (Category of brace sets). The ‘category of brace sets’, i.e. the category of \mathbf{Set} -valued presheaves on the category \mathbb{X} of braces, will be denoted $\widehat{\mathbb{X}}$. \square

Note that the dualization isomorphism $\dagger : \bar{\mathbf{Tr}}_n \cong \overset{\circ}{\mathbf{Tr}}_n$ restricts to an isomorphism of n -truss blocks and n -truss braces $\mathbf{Blk}_n \cong \mathbf{Brc}_n$ and thus provides isomorphisms of presheaf categories $\mathbf{BlkSet}_n \cong \mathbf{BrcSet}_n$ and altogether an isomorphism

$$\widehat{\mathbb{X}} \cong \widehat{\mathbb{X}}.$$

CHAPTER 3

Constructibility of framed combinatorial structures

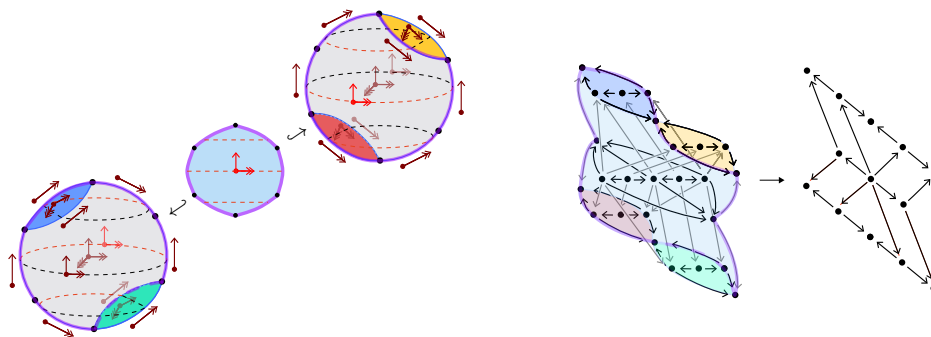

In Chapter 1, we infused classical combinatorial topology with a concept of framings, eventually defining framed regular cells as combinatorial regular cells equipped with locally collapsible simplicial framings. In Chapter 2, we reimagined combinatorial stratified topology through the prism of inductive constructibility, defining trusses as iterated constructible bundles of entrance path posets of stratified intervals. In this chapter, we will ascertain an equivalence between these independently motivated and a priori rather distinct structures: framed regular cells have corresponding integral truss blocks, and truss blocks have corresponding gradient framed regular cells. This identification provides a computable classification, via constructible combinatorics, of framed cell shapes.

We begin this chapter, in Section 3.1, with an illustrated overview of the three fundamental classifications, of framed cells by truss blocks, of collapsible framed cell complexes by closed trusses, and of framed cell complexes by regular block complexes. We then, in Section 3.2, introduce the requisite intermediate structure of proframed simplicial complexes; suitably cellularized, these proframed complexes will have both framed cell complexes as gradients and trusses as fundamental stratified posets. Finally, Section 3.3, we develop the necessary cellularization techniques and assemble the proofs of the classification results.

3.1. Overview of the classifications

We state and illustrate the three primary classification results in increasing generality: the classification of framed regular cells by truss blocks, the classification of collapsible framed regular cell complexes by trusses, and the classification of framed regular cell complexes by regular truss block complexes.

THEOREM 3.1.1 (Truss blocks classify framed regular cells). *n -Framed regular cells are classified by n -truss blocks; that is, there is a canonical equivalence of categories*

$$\text{FrCell}_n \xrightleftharpoons[\nabla_C]{f_T} \text{Blk}_n \quad .$$

In this equivalence, framed regular cells are sent to truss blocks by the ‘truss integration’ functor f_T , and truss blocks are sent to framed regular cells by the ‘cell gradient’ functor ∇_C , which are both explained and constructed in due course.

We illustrate an instance of this equivalence in Figure 3.1. On the left, we depict a 3-framed regular cell by a framed realization in \mathbb{R}^3 (note the same cell appeared earlier in Figure 1.54 and yet earlier in the title picture of Chapter 1); on the right, we depict its corresponding 3-truss block.

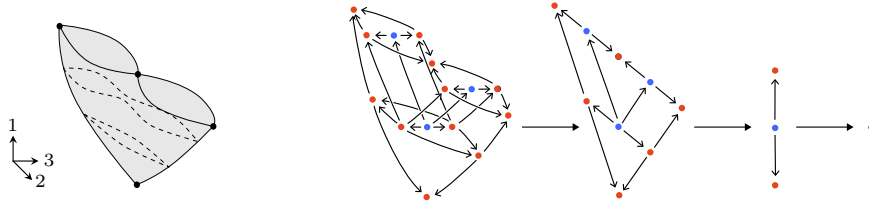

FIGURE 3.1. A framed regular cell and its corresponding truss block.

THEOREM 3.1.2 (Trusses classify collapsible framed regular cell complexes). *Collapsible n -framed regular cell complexes are classified by closed n -trusses and their singular maps; that is, there is a canonical equivalence of categories*

$$\text{CollFrCellCplx}_n \xrightleftharpoons[\nabla_C]{f_T} \bar{\text{Trs}}_n \quad .$$

In fact, the proof of the previous classification of framed regular cells will rely on this classification of framed regular cell complexes, not vice versa as one might expect.

We illustrate an instance of this equivalence in Figure 3.2. On the left, we depict a collapsible 3-framed regular cell complex (note this complex appeared before in Figure 1.55); on the right, we depict its corresponding closed 3-truss.

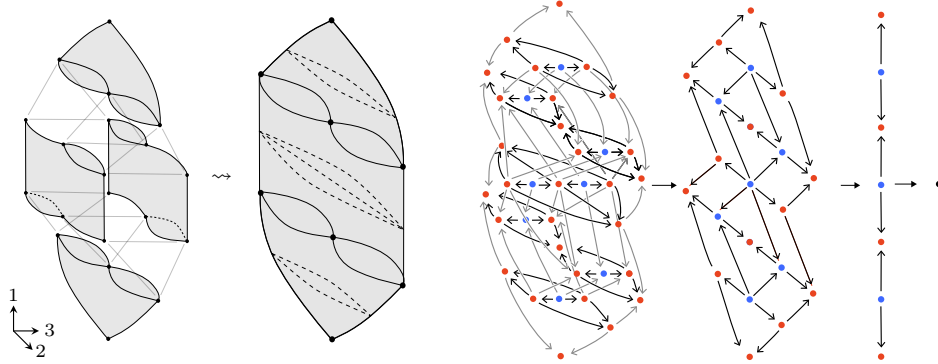

FIGURE 3.2. A collapsible framed regular cell complex and its corresponding closed truss.

THEOREM 3.1.3 (Regular truss block complexes classify framed regular cell complexes). *n -Framed regular cell complexes are classified by regular n -truss block complexes; that is, there is a canonical equivalence of categories*

$$\text{FrCellCplx}_n \xrightleftharpoons[\nabla_{\mathcal{C}}]{\int_{\mathcal{T}}} \text{RBlkCplx}_n .$$

We illustrate an instance of this equivalence in Figure 3.3. On the left, we depict a 2-framed regular cell complex, consisting of two 0-cells, connected by two 1-cells, which together are bounded by two distinct 2-cells (note that this complex appeared earlier in Figure 1.42). On the right, the corresponding truss block complex is depicted by its six nondegenerate truss blocks, each in its own bubble, color-coded to the cells on the left; the face relations are indicated by colored subbubbles.

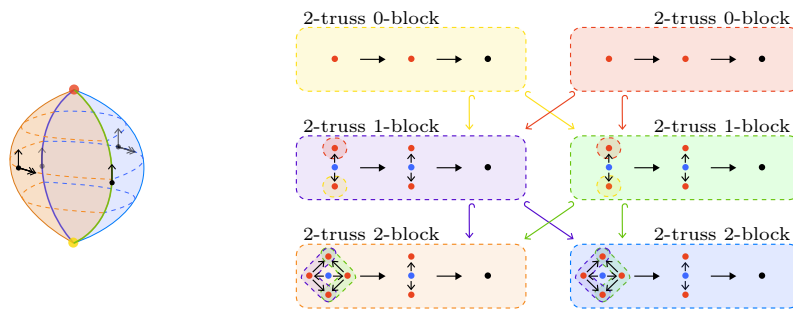

FIGURE 3.3. A framed regular cell complex and its corresponding truss block complex.

3.2. Proframed combinatorial structures

We would like to construct a correspondence, in particular, between framed regular cells and truss blocks. This correspondence (and its generalization to cell complexes and trusses) will proceed via a crucial intermediate structure, namely *proframed simplicial complexes*. Such a complex is a suitable tower of simplicial complexes; see Figure 3.4 for an illustrative example.

Recall that a framed regular cell is in particular a cell-wise collapsible framed simplicial complex. Given such a cell, for instance the one on the left of Figure 3.1, consider the framing as providing a collection of infinitesimal vector fields on the underlying simplicial complex. Imagine *integrating* the maximal frame vector field to a foliation, and then quotienting the complex (and its frame) by that foliation. One may hope that the quotient is itself a framed simplicial complex representing a framed regular cell, and therefore one may iterate the integration process to obtain a tower of regular cells—the underlying simplicial complexes of that tower will form a proframed simplicial complex. Finally, the fundamental posets of the regular cells of that tower will assemble into a truss block, for instance the one on the right of Figure 3.1. Altogether we call this the process of forming the *truss integral*.

To reverse the process, given a truss block, one may realize it to a tower of simplicial complexes, that is to a proframed simplicial complex. The kernels of the projections in that tower provide 1-dimensional foliations of the complexes and one may imagine vector fields tangent to those foliations, along with *gradient-like* vector fields for the projections to the leaves of the foliations, altogether forming a framing structure on the total simplicial complex of the proframe tower. One may hope that the total complex with its framing forms a framed regular cell, providing altogether an inverse process of forming the *cell gradient*.

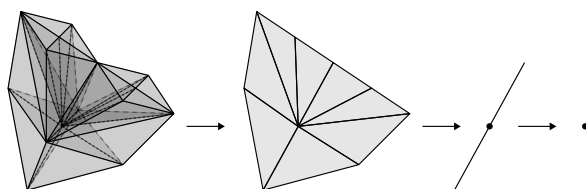

FIGURE 3.4. A proframed simplicial complex.

OUTLINE. In Section 3.2.1, we introduce proframed simplices, their realizations, and maps, and we construct the gradient framed simplex of a proframed simplex and the integral proframed simplex of a framed simplex. In Section 3.2.2, we define proframed simplicial complexes, define the notions of gradient and integral for complexes, introduce a collapsibility condition on proframed complexes, and show that collapsible framings always integrate to collapsible proframings.

3.2.1. Proframed simplices. Recall a frame on the standard simplex is a numeral labeling of its spine. Quotienting by the spine vectors in reverse order of their label numbers provides a ‘proframe’ tower of simplicial projections, each with 1-dimensional affine kernel. We imagine the frame as consisting of *differential* or infinitesimal data of (simplicial) tangent vectors; by contrast we imagine the proframe as consisting of *integral* or global data of (simplicial) projections. This heuristic dichotomy will become more vivid and defensible later in the context of complexes: there the frames remain locally defined simplex by simplex, whereas the proframes will be globally defined via unified projections on the entire complex.

SYNOPSIS. We define proframed simplices, and their partial and embedded generalizations, as towers of simplicial projections with controlled affine kernels. We then describe proframed realizations as affine embeddings of these towers into the standard euclidean proframe. We specify proframed and subproframed maps as suitable transformations of simplicial towers. Finally, we construct the gradient functor taking proframed simplices to framed simplices and the inverse integral functor taking framed simplices to proframed simplices.

3.2.1.1. The definition of proframed simplices. As when we defined framed simplices, we begin with the basic case of proframes, and then generalize to partial, embedded, and embedded partial proframes.

DEFINITION 3.2.1 (Proframe on a simplex). A **proframe** of an m -simplex S is an isomorphism $S \cong [m]$ together with a sequence $\mathcal{P} = (p_m, p_{m-1}, \dots, p_1)$ of surjective simplicial maps of the form

$$[m] \xrightarrow{p_m} [m-1] \xrightarrow{p_{m-1}} [m-2] \xrightarrow{p_{m-2}} \dots \xrightarrow{p_2} [1] \xrightarrow{p_1} [0]. \quad \text{—}$$

We usually denote proframes on S by pairs $(S \cong [m], \mathcal{P})$; we may also keep the isomorphism $S \cong [m]$ implicit, especially when the simplex S was already ordered, writing the proframe as simply (S, \mathcal{P}) or $([m], \mathcal{P})$ or just \mathcal{P} depending on context and convenience.

EXAMPLE 3.2.2 (Proframes on simplices). In Figure 3.5 and Figure 3.6 we illustrate four proframed simplices. The arrows indicate a spine of the simplex (and thus its isomorphism with a standard simplex), and each simplicial degeneracy is indicated by highlighting its affine kernel. —

Recall that a partial frame of a simplex S is a degeneracy $S \twoheadrightarrow [k]$ and a frame on the target simplex $[k]$. A partial proframe is defined analogously, as follows.

DEFINITION 3.2.3 (Partial proframe on a simplex). A **k -partial proframe** on an m -simplex S is a degeneracy $p_\perp : S \twoheadrightarrow [k]$ together with a proframe $\mathcal{P} = (p_k, p_{k-1}, \dots, p_1)$ of the simplex $[k]$. —

We denote k -partial proframes on a simplex S by pairs $(S \twoheadrightarrow [k], \mathcal{P})$. As in the case of partial frames, we refer to the affine kernel $U = \ker^{\text{aff}}(S \twoheadrightarrow$

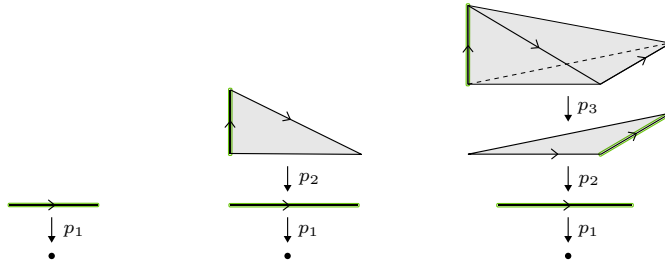

FIGURE 3.5. Proframed simplices.

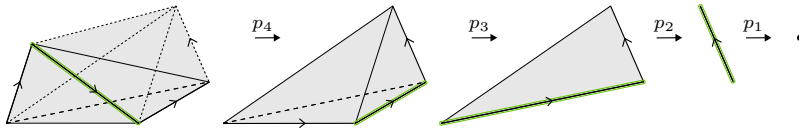

FIGURE 3.6. A proframed 4-simplex.

$[k]$) as the ‘unframed subspace’ of the partially proframed simplex $(S \twoheadrightarrow [k], \mathcal{P})$. Note that in an m -partial proframe of an m -simplex $(S \twoheadrightarrow [m], \mathcal{P})$, the degeneracy $S \twoheadrightarrow [m]$ must be an isomorphism; thus m -partial proframes of m -simplices are simply proframes of m -simplices.

EXAMPLE 3.2.4 (Partial proframes on simplices). In Figure 3.7 we illustrate several partially proframed simplices. As before, each degeneracy is indicated by highlighting its affine kernel; we distinguish in red the ‘unframed subspace’ kernel of the initial degeneracy p_{\perp} and in green the kernels of the other projections p_i . —

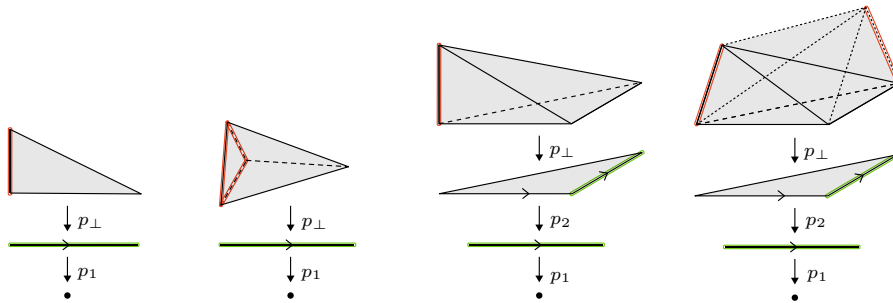

FIGURE 3.7. Partially proframed simplices.

Recall that an embedded frame of a simplex S is an isomorphism $S \cong [m]$ together with a labeling of the vectors of $\text{spine}[m]$ by numerals in $\{1, 2, \dots, n\}$. Quotienting the spine vectors with label n , then those with label $n - 1$, and so on, provides a series of simplicial degeneracies, each of which has affine kernel either containing a single vector or being empty. Such a series provides the notion of embedded proframe, as follows.

DEFINITION 3.2.5 (Embedded proframe on a simplex). An n -**embedded proframe** of an m -simplex S is an isomorphism $S \cong [m]$ together with a sequence $\mathcal{P} = (p_n, p_{n-1}, \dots, p_1)$ of surjective simplicial maps of the form

$$[m] = [m_n] \xrightarrow{p_n} [m_{n-1}] \xrightarrow{p_{n-1}} [m_{n-2}] \xrightarrow{p_{n-2}} \dots \xrightarrow{p_2} [m_1] \xrightarrow{p_1} [m_0] = [0]$$

where for each i , either $m_{i-1} = m_i - 1$ or $m_{i-1} = m_i$. —

We usually denote n -embedded proframed simplices by pairs $(S \cong [m], \mathcal{P})$, abbreviated to (S, \mathcal{P}) or $([m], \mathcal{P})$ or just \mathcal{P} depending. Note that m -embedded proframes of an m -simplex are simply ordinary (non-embedded) proframes.

EXAMPLE 3.2.6 (Embedded proframes). In Figure 3.8 we illustrate a few n -embedded proframed m -simplices. As before, each degeneracy is indicated by highlighting its affine kernel. —

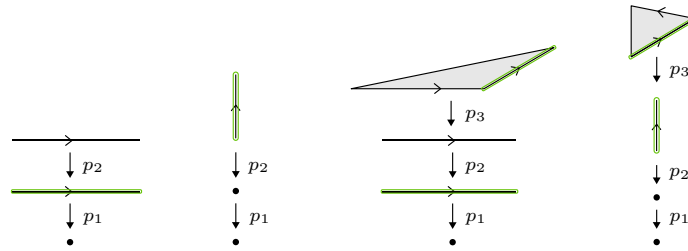

FIGURE 3.8. Embedded proframes on simplices.

Of course we have the conceptual pushout of partial and embedded proframes.

DEFINITION 3.2.7 (Embedded partial proframe on a simplex). An n -**embedded k -partial proframe** on an m -simplex S is a degeneracy $p_\perp : S \twoheadrightarrow [k]$ together with an n -embedded proframe $\mathcal{P} = (p_n, p_{n-1}, \dots, p_1)$ of the simplex $[k]$. —

However, neither partiality nor embedded partiality will be needed for our principal concerns, and so we leave it without illustration or discussion.

3.2.1.2. Proframed realizations. Recall the classical linear algebraic notion of the standard euclidean proframe. From the standard frame (e_1, e_2, \dots, e_n) on \mathbb{R}^n , we may form the spans $\langle e_{n-k+1}, e_{n-k+2}, \dots, e_n \rangle \cong \mathbb{R}^k$; these assemble into the standard euclidean indframe, i.e. linear flag,

$$\mathbb{R}^0 \hookrightarrow \mathbb{R}^1 \hookrightarrow \mathbb{R}^2 \hookrightarrow \dots \hookrightarrow \mathbb{R}^n$$

where $\mathbb{R}^{i-1} \hookrightarrow \mathbb{R}^i$ is the inclusion by adding a leading zero coordinate. The quotients of the total space \mathbb{R}^n by these subspaces \mathbb{R}^k provides a corresponding proframe, i.e. tower of linear projections, as follows.

TERMINOLOGY 3.2.8 (The standard euclidean proframe). The ‘standard euclidean proframe’ of \mathbb{R}^n , denoted $\mathcal{P}_{\mathbb{R}}^n$, is the sequence of projections

$$\mathbb{R}^n \xrightarrow{\pi_n} \mathbb{R}^{n-1} \xrightarrow{\pi_{n-1}} \mathbb{R}^{n-2} \xrightarrow{\pi_{n-2}} \dots \xrightarrow{\pi_2} \mathbb{R}^1 \xrightarrow{\pi_1} \mathbb{R}^0$$

where $\pi_i : \mathbb{R}^i \rightarrow \mathbb{R}^{i-1}$ forgets the last coordinate of \mathbb{R}^i . —

See Section A.1 for an explication of classical linear frames, indframes, and proframes, and their embedded generalizations.

Recall that a framed realization of a (possibly embedded) framed simplex was an embedding of the simplex in euclidean space, that suitably respected the frame structure on spine vectors. Analogously a proframed realization of a (possibly embedded) proframed simplex is an embedding of the proframe tower into the standard euclidean proframe tower, that suitably respects the proframe structure on spine vectors.

DEFINITION 3.2.9 (Proframed realization of an embedded proframed simplex). A **proframed realization** of an n -embedded proframed simplex $(S \cong [m], \mathcal{P} = (p_n, p_{n-1}, \dots, p_1))$ is a sequence of linear embeddings $r_i^{\mathcal{P}} : \Delta^{m_i} \hookrightarrow \mathbb{R}^i$, giving a commutative diagram,

$$\begin{array}{ccccccc} |S| & \xrightarrow{\cong} & \Delta^{m_n} & \xrightarrow{p_n} & \Delta^{m_{n-1}} & \xrightarrow{p_{n-1}} & \dots & \xrightarrow{p_2} & \Delta^{m_1} & \xrightarrow{p_1} & \Delta^{m_0} \\ & \searrow & \downarrow r_n^{\mathcal{P}} & & \downarrow r_{n-1}^{\mathcal{P}} & & & & \downarrow r_1^{\mathcal{P}} & & \downarrow r_0^{\mathcal{P}} \\ & & \mathbb{R}^n & \xrightarrow{\pi_n} & \mathbb{R}^{n-1} & \xrightarrow{\pi_{n-1}} & \dots & \xrightarrow{\pi_2} & \mathbb{R}^1 & \xrightarrow{\pi_1} & \mathbb{R}^0 \end{array}$$

such that, for any spine vector $v \subset \Delta^{m_i}$ that is degenerated by the projection p_i , the image $r_i^{\mathcal{P}}(v) \subset \mathbb{R}^i$ is a positive vector in the fiber $\pi_i^{-1}(r_{i-1}^{\mathcal{P}}(p_i(v)))$. —

The definition specializes, of course, to proframed realization of (non-embedded) proframed m -simplices, in which case $m_i = i$ throughout. It also straightforwardly generalizes to the partial proframed and embedded partial proframed cases: for the n -embedded k -partial case, simply replace the isomorphism $|S| \xrightarrow{\cong} \Delta^{m_n}$ in the diagram by the degeneracy $|S| \xrightarrow{p_{\perp}} \Delta^k$, and replace Δ^{m_i} by Δ^{k_i} throughout (with $k_n := k$); for the (non-embedded) k -partial case, furthermore note $k_i = i$.

EXAMPLE 3.2.10 (Proframed realizations). In Figure 3.9 we illustrate a proframed realization of each of a proframed, partial proframed, embedded proframed, and embedded partial proframed simplex, respectively. —

3.2.1.3. Proframed maps. Recall that a framed map is a map of simplices that, for each vector of the source, either preserves the frame label of the vector or else degenerates the vector. Analogously, a proframed map will be a map of simplicial towers, that for each vector in the total simplex of the source, either preserves the whole proframe restricted to that vector or else degenerates that vector, as follows.

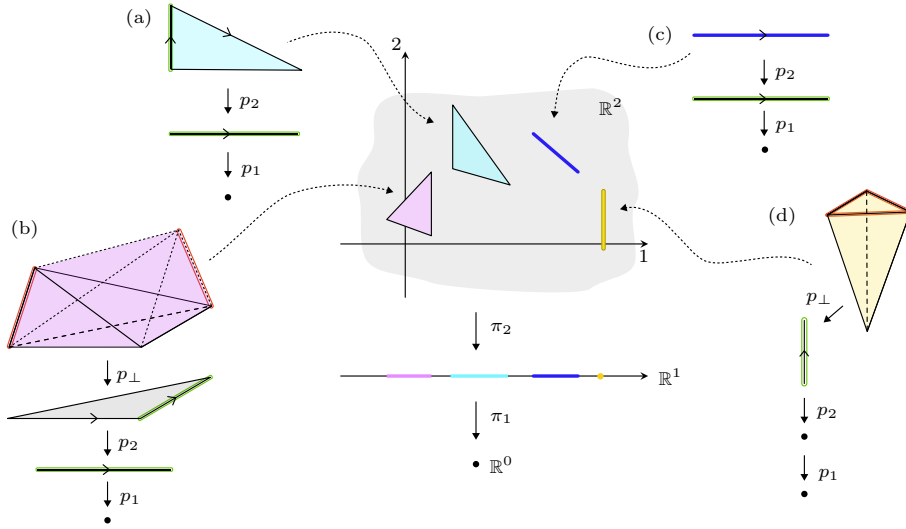

FIGURE 3.9. Proframed realizations of proframed simplices.

DEFINITION 3.2.11 (Proframed maps). Given n -embedded proframed simplices $(S \cong [l], \mathcal{P} = (p_n, \dots, p_1))$ and $(T \cong [m], \mathcal{Q} = (q_n, \dots, q_1))$, a **proframed map** $F : (S \cong [l], \mathcal{P}) \rightarrow (T \cong [m], \mathcal{Q})$ is a map of sequences

$$\begin{array}{ccccccc}
 [l] = [l_n] & \xrightarrow{p_n} & [l_{n-1}] & \xrightarrow{p_{n-1}} & \cdots & \xrightarrow{p_2} & [l_1] & \xrightarrow{p_1} & [l_0] = [0] \\
 F_n \downarrow & & F_{n-1} \downarrow & & \cdots & & \downarrow F_1 & & \downarrow F_0 \\
 [m] = [m_n] & \xrightarrow{q_n} & [m_{n-1}] & \xrightarrow{q_{n-1}} & \cdots & \xrightarrow{q_2} & [m_1] & \xrightarrow{q_1} & [m_0] = [0]
 \end{array}$$

such that for every vector $v : [1] \rightarrow [l]$, either its proframe is preserved, i.e. $F : \mathcal{P}|_v \cong \mathcal{Q}|_{F_n \circ v}$, or the vector is degenerated, i.e. $F_n \circ v : [1] \rightarrow [m]$ is constant. —

NOTATION 3.2.12 (Category of proframed simplices). The category of n -embedded proframed simplices and their proframed maps is denoted ProFrSimp_n . —

REMARK 3.2.13 (Subproframed maps). Recall from Remark 1.1.74 and Definition 1.1.75 that, unlike a framed map, a subframed map of framed simplices may send a vector to a vector with a more specialized frame label. The corresponding notion of subproframed map of proframed simplices is rather natural, as follows. Given n -embedded proframed simplices $(S \cong [l], \mathcal{P} = (p_n, \dots, p_1))$ and $(T \cong [m], \mathcal{Q} = (q_n, \dots, q_1))$, a subproframed map $F : (S \cong [l], \mathcal{P}) \rightarrow (T \cong [m], \mathcal{Q})$ is a map of sequences of unordered simplices,

$$\begin{array}{ccccccc}
 [l_n]^{\text{un}} & \xrightarrow{p_n} & [l_{n-1}]^{\text{un}} & \xrightarrow{p_{n-1}} & \cdots & \xrightarrow{p_2} & [l_1]^{\text{un}} & \xrightarrow{p_1} & [l_0]^{\text{un}} \\
 F_n \downarrow & & F_{n-1} \downarrow & & \cdots & & \downarrow F_1 & & \downarrow F_0 \\
 [m_n]^{\text{un}} & \xrightarrow{q_n} & [m_{n-1}]^{\text{un}} & \xrightarrow{q_{n-1}} & \cdots & \xrightarrow{q_2} & [m_1]^{\text{un}} & \xrightarrow{q_1} & [m_0]^{\text{un}}
 \end{array}$$

such that any ordered vector $v : [1] \rightarrow [l_i]$ with $p_i \circ v : [1] \rightarrow [l_{i-1}]$ constant, is sent to an ordered vector $F_i \circ v : [1] \rightarrow [m_i]$. The structure of the sequence itself controls the specialization of the proframed vectors, without mention of frame labels or the standard stratification of euclidean frame vectors. \square

The notions of proframed and subproframed maps generalize straightforwardly to the case of embedded partial proframes, but we omit such a discussion.

3.2.1.4. Gradients and integrals for simplices. Recall that we informally think of frames as infinitesimal data, concerning tangential vectors, and of proframes as global data, concerning foliations. We now describe the translation between these structures: we will refer to the process of taking a proframe and constructing a frame as forming a ‘gradient’, and we will refer to the converse passage from a frame to a proframe as ‘integration’.²⁵

We begin with the gradient frame of a proframe. (For convenience, we will mainly work with ordered simplices $[m]$ rather than unordered simplices with a chosen order $S \cong [m]$ as before.)

NOTATION 3.2.14 (Composite projections in proframes). For an n -embedded proframe $\mathcal{P} = (p_n, \dots, p_1)$ of the simplex $[m]$, we abbreviate the composite $p_{i+1} \cdots p_n : [m] \rightarrow [m_i]$ by $p_{\rightarrow i}$. \square

DEFINITION 3.2.15 (Gradient frame). Given an n -embedded proframed m -simplex $([m], \mathcal{P} = (p_n, \dots, p_1))$, its **gradient frame** $\nabla \mathcal{P}$ is the n -embedded framed m -simplex $([m], \nabla \mathcal{P} : \mathbf{spine}[m] \hookrightarrow \underline{n})$ defined, for all i , by

$$\nabla \mathcal{P}(v) = i \quad \text{for } v \in \ker^{\text{aff}}(p_{\rightarrow i-1}) \setminus \ker^{\text{aff}}(p_{\rightarrow i}). \quad \square$$

In other words, if the spine vector $v \in \mathbf{spine}[m]$ projects to a spine vector $p_{\rightarrow i}v \in \mathbf{spine}[m_i]$ and the projection $p_i : [m_i] \rightarrow [m_{i-1}]$ degenerates that vector $p_{\rightarrow i}v$ to a constant $p_{\rightarrow i-1}v$, then the spine vector $v \in \mathbf{spine}[m]$ is given the label i .

As in classical geometric situations, in general the converse process of integration is less procedural and any potential construction is less assured to work. As such, we define the integral as a formal right inverse to the gradient.

DEFINITION 3.2.16 (Integral proframe). Given an n -embedded framed m -simplex $([m], \mathcal{F} : \mathbf{spine}[m] \hookrightarrow \underline{n})$, an **integral proframe** $\int \mathcal{F}$ is an n -embedded proframe on the simplex $[m]$, whose gradient $\nabla \int \mathcal{F}$ is the given frame \mathcal{F} . \square

However, in the special case of simplices, we do have an effective construction of integral proframes, as follows.

CONSTRUCTION 3.2.17 (Integral proframe of an embedded frame). For an n -embedded framed m -simplex $([m], \mathcal{F} : \mathbf{spine}[m] \hookrightarrow \underline{n})$, an integral proframe

²⁵The reference relationship between frames and proframes in the classical linear and affine algebraic case is discussed in [Chapter A](#).

◊ Image of proframed map and subproframed map – see old numbered pix

is given by the n -embedded proframed m -simplex $([m], f\mathcal{F} = (p_n, \dots, p_1))$ obtained by inductively setting $p_i : [m_i] \rightarrow [m_{i-1}]$ to be the simplicial map collapsing the spine vector $p_{\rightarrow i}(\mathcal{F}^{-1}(i))$, i.e. the spine vector with frame label i ; if there is no spine vector with frame label i , then p_i is set to be the identity. —

OBSERVATION 3.2.18 (The gradient and integral for simplices are inverse). For any n -embedded proframe \mathcal{P} of a simplex and any n -embedded frame \mathcal{F} of a simplex, we have

$$\nabla f\mathcal{F} = \mathcal{F} \quad \text{and} \quad f\nabla\mathcal{P} = \mathcal{P}. \quad \text{—}$$

Thus in the case of simplices, the integral always exists and is a two-sided inverse to the gradient; but later in the more general case of simplicial complexes, we will find that, though all proframes are differentiable, some frames fail to be uniquely integrable or even integrable at all.

EXAMPLE 3.2.19 (Gradient frame and integral proframe). In Figure 3.10 we illustrate a 4-embedded framed 3-simplex and its integral 4-embedded proframed 3-simplex; equivalently, that proframed simplex has gradient that framed simplex. —

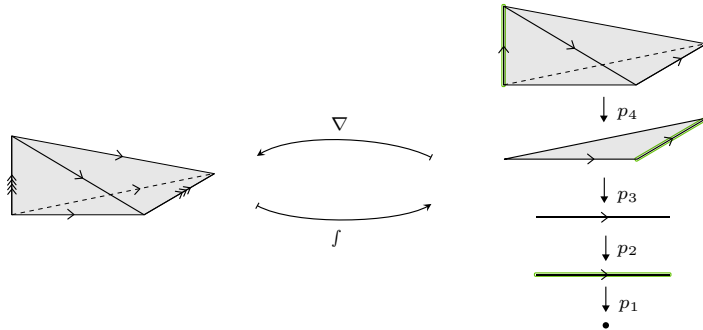

FIGURE 3.10. The gradient frame and the integral proframe.

As one can expect, gradients and integrals generalize from the embedded case to the embedded partial case.

To promote the above gradients and integrals to functors, we next construct them on framed and proframed maps.

OBSERVATION 3.2.20 (Gradients and integrals respect restriction). Given an n -embedded proframed simplex $(S \cong [m], \mathcal{P})$ and an n -embedded framed simplex $(S \cong [m], \mathcal{F})$, and a face $f : [j] \rightarrow [m]$, the gradient of the restriction to the face is the restriction of the gradient, and similarly for the integrals:

$$\nabla(\mathcal{P}|_f) = (\nabla\mathcal{P})|_f \quad \text{and} \quad f(\mathcal{F}|_f) = (f\mathcal{F})|_f. \quad \text{—}$$

TERMINOLOGY 3.2.21 (Gradient framed map of a proframed map). Given an n -embedded proframed simplex $(S \cong [j], \mathcal{P})$, an n -embedded proframed simplex $(T \cong [k], \mathcal{Q})$, and a proframed map $F : (S \cong [j], \mathcal{P}) \rightarrow (T \cong [k], \mathcal{Q})$, the ‘gradient’ ∇F is simply the framed map $(S \cong [j], \nabla \mathcal{P}) \rightarrow (T \cong [k], \nabla \mathcal{Q})$ determined by the simplicial map $F : S \rightarrow T$. —

TERMINOLOGY 3.2.22 (Integral proframed map of a framed map). Given an n -embedded framed simplex $(S \cong [j], \mathcal{F})$, an n -embedded framed simplex $(T \cong [k], \mathcal{G})$, and a framed map $F : (S \cong [j], \mathcal{F}) \rightarrow (T \cong [k], \mathcal{G})$, an ‘integral’ $\int F$ is a proframed map $(S \cong [j], \int \mathcal{F}) \rightarrow (T \cong [k], \int \mathcal{G})$ whose gradient is the framed map F . —

Just as there exists a unique integral proframe of any framed simplex, there exists a unique integral proframed map of any framed map; that integral proframed map is constructed by setting its top component $F_n : [j] \rightarrow [k]$ to be the given framed map $F : [j] \rightarrow [k]$, and observing that the condition that F is framed ensures the map F_n descends to maps $F_i : [j_i] \rightarrow [k_i]$ as required. This yields gradient and integral functors, which assemble into an equivalence of categories as follows.

OBSERVATION 3.2.23 (Correspondence of frames and proframes). The gradient and integral functors are inverse equivalences between the category of n -embedded framed simplices with framed maps and the category of n -embedded proframed simplices with proframed maps:

$$\nabla : \text{ProFrSimp}_n \cong \text{FrSimp}_n : \int \text{—}$$

REMARK 3.2.24 (Correspondence of framed and proframed realizations). Given an n -embedded proframed simplex $(S \cong [m], \mathcal{P})$ with corresponding gradient framed simplex $(S \cong [m], \mathcal{F} = \nabla \mathcal{P})$, any proframed realization $\{r_i^{\mathcal{P}} : \Delta^{m_i} \hookrightarrow \mathbb{R}^i\}$ determines and is determined by a framed realization $r_{\mathcal{F}} : |S| \cong \Delta^{m_n} \hookrightarrow \mathbb{R}^n$ by equating $r_n^{\mathcal{P}} = r_{\mathcal{F}}$. —

3.2.2. Proframed simplicial complexes. Recall a framing of a simplicial complex is a local notion: it is simply a framing of each of its simplices, compatible with restriction. A proframing of a simplicial complex will be by contrast a global notion, namely a suitable tower of projections of complexes. As anticipated, there will always be a gradient framed complex associated to a proframed complex, but only certain framed complexes, namely the collapsible one, will be integrable.

SYNOPSIS. We defined proframings of simplicial complexes as towers of projections that restrict to proframings on every simplex. We then define gradients for proframed complexes and discuss integrability of framed complexes. Finally we introduce the notion of collapsible proframing and show that collapsible framed complexes always have an integral collapsible proframing.

3.2.2.1. The definition of proframed simplicial complexes. Recall from Definition 1.2.9 a framing of a simplicial complex may be considered as an ordering on the complex and a compatible collection of framings on its ordered simplices. We take a similar approach to defining proframed complexes.

DEFINITION 3.2.25 (Proframings of simplicial complexes). An n -**proframing** of a simplicial complex K is an ordering of K together with a sequence $\mathcal{P} = (p_n, p_{n-1}, \dots, p_1)$ of ordered simplicial surjections

$$K = K_n \xrightarrow{p_n} K_{n-1} \xrightarrow{p_{n-1}} \dots \xrightarrow{p_2} K_1 \xrightarrow{p_1} K_0 = [0]$$

such that on each simplex $x : [m] \hookrightarrow K$, the restricted sequence $\mathcal{P}|_x$ is an n -embedded proframe of that simplex $[m]$. —

Naturally we will refer to the pair (K, \mathcal{P}) of a simplicial complex with an n -proframing $\mathcal{P} = (p_n, p_{n-1}, \dots, p_1)$ as an ‘ n -proframed simplicial complex’. For convenience we will keep the ordering implicit; henceforth, we simply say ‘simplicial complex’ in place of ‘simplicial complex with a choice of ordering’, and we assume all simplicial maps are order preserving.

EXAMPLE 3.2.26 (Proframings of complexes). In Figure 3.11 we illustrate three 2-proframed simplicial complexes. Each projection p_i is suggested as a geometric projection, but we also highlight the affine kernels of every p_i on each simplex, as before. —

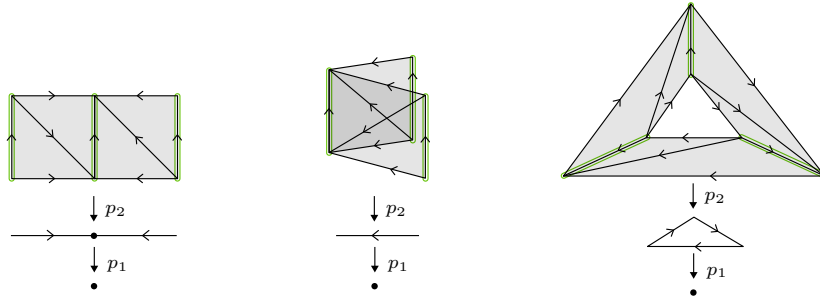

FIGURE 3.11. 2-Proframings of simplicial complexes.

DEFINITION 3.2.27 (Maps of proframings). Given n -proframed simplicial complexes $(K, \mathcal{P} = (p_n, \dots, p_1))$ and $(L, \mathcal{Q} = (q_n, \dots, q_1))$, a **proframed map** $F : (K, \mathcal{P}) \rightarrow (L, \mathcal{Q})$ is a map of sequences

$$\begin{array}{ccccccc} K = K_n & \xrightarrow{p_n} & K_{n-1} & \xrightarrow{p_{n-1}} & \dots & \xrightarrow{p_2} & K_1 & \xrightarrow{p_1} & K_0 = [0] \\ F_n \downarrow & & F_{n-1} \downarrow & & \dots & & \downarrow F_1 & & \downarrow F_0 \\ L = L_n & \xrightarrow{q_n} & L_{n-1} & \xrightarrow{q_{n-1}} & \dots & \xrightarrow{q_2} & L_1 & \xrightarrow{q_1} & L_0 = [0] \end{array}$$

such that, on every simplex $x : [k] \hookrightarrow K$, with image $y = \text{im}(F_n \circ x) : [l] \hookrightarrow L$, the sequence restricts to a proframed map $F : \mathcal{P}|_x \rightarrow \mathcal{Q}|_y$ of n -embedded proframed simplices. ---

NOTATION 3.2.28 (Category of proframings). The category of n -proframed simplicial complexes and their proframed maps will be denoted by ProFrSimpCplx_n . ---

NOTATION 3.2.29 (Truncations of proframings). Given an n -proframing $\mathcal{P} = (K_n \xrightarrow{p_n} K_{n-1} \xrightarrow{p_{n-1}} \cdots \xrightarrow{p_1} K_0)$ of the simplicial complex K , its (lower) ‘ i -truncation’ $\mathcal{P}_{\leq i}$ is the i -proframing $(K_i \xrightarrow{p_i} K_{i-1} \xrightarrow{p_{i-1}} \cdots \xrightarrow{p_1} K_0)$ of the simplicial complex K_i . By similarly truncating maps, we obtain i -truncation functors $(-)\leq i : \text{ProFrSimpCplx}_n \rightarrow \text{ProFrSimpCplx}_i$. ---

3.2.2.2. Gradients and integrals for simplicial complexes. From a proframed simplicial complex, we can constructively form the associated gradient framed simplicial complex, as follows.

DEFINITION 3.2.30 (Gradients of proframed simplicial complexes). Given an n -proframing \mathcal{P} of a simplicial complex K , the **gradient framing** $\nabla \mathcal{P}$ is the n -framing of K with the same ordering as \mathcal{P} and with the n -embedded frame $(\nabla \mathcal{P})_x$ on each simplex $x : [m] \hookrightarrow K$ given by the gradient frame $\nabla(\mathcal{P}|_x)$ of the restricted proframe $\mathcal{P}|_x$. ---

The fact that the frames $(\nabla \mathcal{P})_x$ are compatible with face restrictions, as required, follows from the compatibility of gradients with face restriction, as in [Observation 3.2.20](#).

DEFINITION 3.2.31 (Gradients of proframed maps). Given a proframed map $F = (F_n, F_{n-1}, \dots, F_1, F_0) : (K, \mathcal{P}) \rightarrow (L, \mathcal{Q})$ of n -proframed simplicial complexes, the **gradient framed map** $\nabla F : (K, \nabla \mathcal{P}) \rightarrow (L, \nabla \mathcal{Q})$ is the framed map given by the simplicial map $F_n : K \rightarrow L$. ---

TERMINOLOGY 3.2.32 (The gradient framing functor). The construction of gradients on proframings and their maps yields the ‘gradient framing’ functor

$$\nabla : \text{ProFrSimpCplx}_n \rightarrow \text{FrSimpCplx}_n. \quad \text{---}$$

Going the other way, we would like to take a framing and produce an integral proframing, which is to say something whose gradient is the original framing, as follows.

DEFINITION 3.2.33 (Integral proframings). Given an n -framed simplicial complex (K, \mathcal{F}) , an **integral proframing** of (K, \mathcal{F}) is an n -proframed simplicial complex (K, \mathcal{P}) whose gradient framing $\nabla \mathcal{P}$ is the given framing \mathcal{F} . ---

However, not all framings are *integrable*, and even for an integrable framing, the integral proframing may not be unique.

EXAMPLE 3.2.34 (Non-uniqueness of integral proframings). In Figure 3.12 we illustrate a 2-proframed simplicial complex and its gradient, a 2-framed simplicial complex. Note that the proframing is not the unique integral of the framing: another integral proframing could be obtained by modifying p_2 to have only a single 1-simplex in its image. —

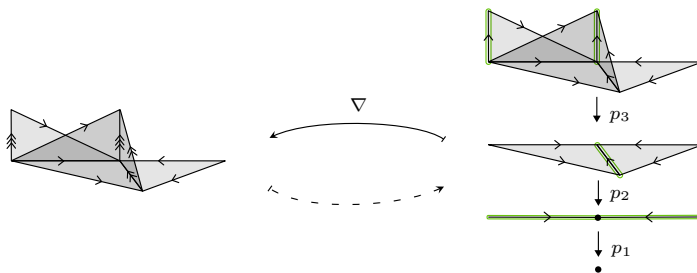

FIGURE 3.12. Proframed simplicial complex with its gradient framing.

EXAMPLE 3.2.35 (Non-integrable framings). In Figure 3.13 we depict two 2-framings of the boundary $\partial[2]^{\text{un}}$ of the unordered 2-simplex $[2]^{\text{un}}$. Neither framing admits an integral proframing. —

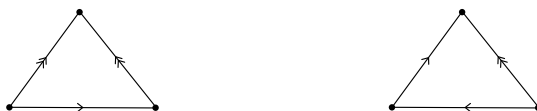

FIGURE 3.13. Two framings without integral proframings.

REMARK 3.2.36 (Integrating simplex boundary framings). The failures of integrability in the previous example may be seen in the context of the following more general observation. An n -framing \mathcal{F} of the unordered simplex boundary $\partial[m]^{\text{un}}$ is integrable if and only if it is the restriction of some n -framing $\bar{\mathcal{F}}$ of the unordered m -simplex $[m]^{\text{un}}$; that is, $\mathcal{F} = \bar{\mathcal{F}}|_{\partial[m]^{\text{un}}}$. —

3.2.2.3. Collapsible proframings. Recall that a collapsible framing is a framing that admits a sequence of elementary simplicial collapses degenerating all the frame vectors in descending order, such that suitable collapse subsequences satisfy unique lifting properties. We will define an analogous notion of collapsibility for proframings, and then show that collapsible framings have unique integral collapsible proframings.

The notion of collapsible proframing will be formulated in terms of fiber categories, which we develop presently, of the component projections of the proframing.

TERMINOLOGY 3.2.37 (Fiber set). Given a simplicial map $p : K \rightarrow K'$, and a simplex $z : [m] \hookrightarrow K'$, the ‘fiber set’ over z is the set of all simplices $x : [k] \hookrightarrow K$ such that the composite $p \circ x$ has image identical to the image of z ; denote, leaving the map p implicit, the fiber set over z by K_z . —

Simplices in fiber sets K_z of proframing projections $p_i : K_i \rightarrow K_{i-1}$ fall into only two classes, as follows.

DEFINITION 3.2.38 (Section and spacer simplices in proframings). Given an n -proframed simplicial complex (K, \mathcal{P}) and a simplex $x : [k] \hookrightarrow K_i$ in the fiber set over $z : [m] \hookrightarrow K_{i-1}$, then the simplex x is a **section simplex** if $k = m$ and a **spacer simplex** if $k = m + 1$. —

TERMINOLOGY 3.2.39 (Upper and lower sections of spacers). Consider an n -proframed simplicial complex (K, \mathcal{P}) and a spacer simplex $x : [k] \hookrightarrow K_i$. Let $v : [1] \rightarrow [k]$ be the unique simplicial vector in the affine kernel of $p_i \circ x$.

- ▷ The ‘upper section’ $\partial^+ x : [k-1] \hookrightarrow K_i$ of x is the face of x not containing $x \circ v(0)$.
- ▷ The ‘lower section’ $\partial^- x : [k-1] \hookrightarrow K_i$ of x is the face of x not containing $x \circ v(1)$. —

Given a spacer simplex x , its upper and lower sections $\partial^\pm x$ are, in particular, section simplices in the previous sense.

DEFINITION 3.2.40 (Fiber categories). Consider an n -proframed simplicial complex $(K, \mathcal{P} = (p_n, \dots, p_1))$ and a simplex $z : [m] \hookrightarrow K_{i-1}$. The **fiber category** over z , denoted $\Phi_{\mathcal{P}}(z)$, is the free category whose objects are section simplices $y \in K_z$, and whose generating morphisms $y_- \rightarrow y_+$ are spacer simplices $x \in K_z$ with $y_\pm = \partial^\pm x$. —

CONSTRUCTION 3.2.41 (Transition functors of fiber categories). For an n -proframed simplicial complex (K, \mathcal{P}) , consider simplices $z : [m] \hookrightarrow K_{i-1}$ and $w : [l] \hookrightarrow K_{i-1}$ such that w is a face of z . Note that each simplex $x \in K_z$ in the fiber set over z , has a face simplex $x|_{w \subset z} \in K_w$ in the fiber set over w . Moreover, this restriction $x \mapsto x|_{w \subset z}$ takes sections to sections, but takes spacers either to spacers or to sections. The restriction thus induces a ‘transition functor’ $-|_{w \subset z} : \Phi_{\mathcal{P}}(z) \rightarrow \Phi_{\mathcal{P}}(w)$. —

EXAMPLE 3.2.42 (Fiber categories and transition functors). In Figure 3.14, for the indicated 3-proframing $K_3 \xrightarrow{p_3} K_2 \rightarrow \dots$, we depict the fiber categories and transition functors for selected simplices in K_2 . Note that each fiber category object (indicated by a colored circle) corresponds to a section simplex, and each generating morphism (indicated by a colored arrow) corresponds to a spacer simplex. The transition functors between fiber categories are indicated by dotted arrows. —

We now have the components in place to define collapsibility for proframings.

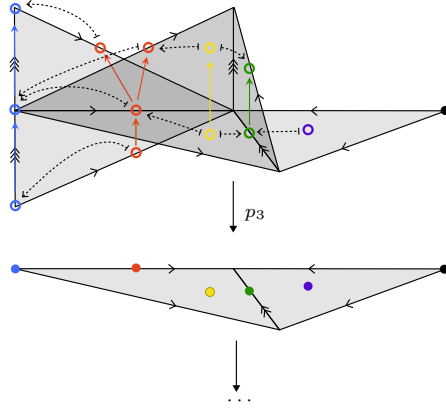

FIGURE 3.14. Fiber categories and transition functors.

DEFINITION 3.2.43 (Collapsible proframings). An n -profamed simplicial complex $(K, \mathcal{P} = \{K_i \xrightarrow{p_i} K_{i-1}\})$ is **collapsible** if, either $n = 0$ and K is the point $*$, or $n > 0$ and the following two conditions hold.

- (1) *Fibers are linear*: For any simplex $z : [m] \hookrightarrow K_{i-1}$, the fiber category $\Phi_{\mathcal{P}}(z)$ is a total order.
- (2) *Fiber transitions are endpoint-preserving*: For simplices $w \subset z$ in K_{i-1} the transition functor $-|_{w \subset z}$ is endpoint-preserving, that is it preserves least and greatest elements as a map of total orders. \square

REMARK 3.2.44 (Linear complexes). We will refer to a simplicial complex consisting of 0- and 1-simplices, whose geometric realization is either a point or a closed interval, as a ‘linear complex’. For a collapsible proframing $(K, \mathcal{P} = (p_n, p_{n-1}, \dots, p_1))$, the preimages $p_i^{-1}(x)$ of 0-simplices x are linear subcomplexes of K_i . \square

NOTATION 3.2.45 (Category of collapsible proframings). The full subcategory of the category of n -profamed simplicial complexes, with objects the collapsible proframings, is denoted by $\text{CollProFrSimpCplx}_n$. \square

We now prove that collapsible n -framings have unique integral collapsible proframings. First, let us unpack the definition of collapsible framings (Definition 1.2.31) and observe the following analogy with the fiberwise conditions of collapsible proframings (Definition 3.2.43).

OBSERVATION 3.2.46 (Fiberwise perspective on collapsible framings). Given a collapsible n -framed simplicial complex (K, \mathcal{F}) , recall that the quotient map $q_n : K = K_n \rightarrow K_{n-1}$ collapses all the n -frame vectors and that K_{n-1} itself carries inductively a collapsible framing. There are two kinds of simplices in the fiber of q_n over $z : [m] \hookrightarrow K_{n-1}$: ‘section’ simplices $x \in K_z$, which do not contain n -frame vectors, and ‘spacer’ simplices $y \in K_z$, which do contain n -frame vectors. By definition of elementary collapse (see Terminology 1.2.25), the fiber over each base simplex z must organize into a graph with sections as vertices and spacers as edges, satisfying the following:

- › the graph is connected;
- › the graph has no cycles (which would contradict the quotient being a simplicial complex);
- › the graph obtains a directionality inherited from the directionality of the n -frame vectors.

In fact, by the flow uniqueness of collapsible framings, the fiber over each base simplex z must be a linear directed graph (in that it generates a total order). —

PROPOSITION 3.2.47 (Integrals of collapsible framings). *Collapsible n -framings have unique (up to isomorphism) integral collapsible proframings.*

PROOF. Let (K, \mathcal{F}) be a collapsible n -framed simplicial complex. Recall from Definition 1.2.31 that there is a map $q_n : K = K_n \rightarrow K_{n-1}$ collapsing all the n -frame vectors and that K_{n-1} itself carries inductively a collapsible framing, so there is another map $q_{n-1} : K_{n-1} \rightarrow K_{n-2}$ collapsing all the $(n-1)$ -frame vectors, and so on. This provides a tower of simplicial quotient maps:

$$K = K_n \xrightarrow{q_n} K_{n-1} \xrightarrow{q_{n-1}} \dots \xrightarrow{q_2} K_1 \xrightarrow{q_1} K_0 = [0]$$

By construction, the gradient of this tower is the original framing, and so we have produced an n -proframing \mathcal{Q} integrating \mathcal{F} .

However, we must still verify that \mathcal{Q} is collapsible in the sense of Definition 3.2.43. Arguing inductively, it suffices to check this for the fibers and fiber transitions of q_n . Observe that for any simplex $z : [m] \hookrightarrow K_{n-1}$, the fiber category $\Phi_{\mathcal{Q}}(z)$ must be connected, since q_n is a quotient of n -vectors, and q_n maps all simplices in the fiber over z to the single simplex z . By Observation 3.2.46, $\Phi_{\mathcal{Q}}(z)$ must be a total order. Moreover, from the flow existence property it follows that fiber transitions are endpoint-preserving.

It remains to show that \mathcal{Q} is the unique collapsible integral proframing of \mathcal{F} . Assume there exists another collapsible integral n -proframing $(K, \mathcal{P} = (p_n, p_{n-1}, \dots, p_2, p_1))$ of \mathcal{F} . Since p_k must degenerate all k -frame vectors, the universal property of quotients yields a surjective simplicial map of towers $F : \mathcal{Q} \rightarrow \mathcal{P}$. Arguing by contradiction, take the lowest index i such that F_i is not a simplicial isomorphism. In particular, F_i fails to be an isomorphism of the fibers $q_i^{-1}(x)$ and $p_i^{-1}(y)$, where $y = F_{i-1}(x)$, for some $x \in K_{i-1}$. Since F_i is a simplicial surjection, $p_i^{-1}(y)$ must be a strictly smaller linear complex, and thus $F_i : q_i^{-1}(x) \rightarrow p_i^{-1}(y)$ degenerates at least one 1-simplex in $q_i^{-1}(x)$. By inductively lifting that simplex to a 1-simplex of $K = K_n$ using the flow existence property, one derives a contradiction: that lifted simplex cannot have the same frame label in \mathcal{Q} and \mathcal{P} , which contradicts the assumption that they have the same gradient. □

REMARK 3.2.48 (Gradient collapsibility is insufficient). Note that given an n -proframing \mathcal{P} , requiring that the gradient framing $\nabla \mathcal{P}$ be collapsible, does not ensure that the proframing itself is collapsible. —

OBSERVATION 3.2.49 (Integration as a functor). Given an n -framed map $F : (K, \mathcal{F}) \rightarrow (L, \mathcal{G})$ of collapsible framed simplicial complexes, the integral n -proframed map $fF : (K, f\mathcal{F}) \rightarrow (L, f\mathcal{G})$ is inductively constructed by setting $F = F_n$ and then defining F_{i-1} such that $p_i \circ F_i = F_{i-1} \circ q_i$ where q_i and p_i are the i th maps in the proframings $f\mathcal{F}$ and $f\mathcal{G}$, respectively. The association from collapsible framings to their unique integral collapsible proframings thus provides a functor

$$f : \text{CollFrSimpCplx}_n \rightarrow \text{CollProFrSimpCplx}_n \quad \text{---} \quad \square$$

This observation, together with previous definitions and constructions, assembles into the following result.

PROPOSITION 3.2.50 (Gradient and integral equivalence). *The gradient and integral functors yield an equivalence of categories*

$$\nabla : \text{CollProFrSimpCplx}_n \simeq \text{CollFrSimpCplx}_n : f \quad \square$$

3.3. Proofs of the classifications

Recall the lullaby from the introduction to Section 3.2: take your framed regular cell and consider the underlying framed simplicial complex, inductively quotient by the integral foliations of the highest frame vectors to obtain a proframed simplicial complex, then take the fundamental poset to deliver a truss block; conversely realize your truss block to a proframed simplicial complex, and assemble gradient-like vector fields for the various subquotients in the proframing, to produce a framed simplicial structure supporting a framed cell. It is now time to actually establish the correspondence so adumbrated.

In detailing and making precise the necessary processes of forming the *integral truss* and conversely the *gradient cell*, a crucial matter arises, which is to demonstrate that the face-order posets of trusses are actually cellular. By definition this requires the component truss blocks to have spherical boundaries; in a bit of excess we show this by proving that truss block posets actually have *shellable* piecewise linear spherical boundaries. Roughly speaking, a spherical complex is shellable when its facets can be removed in some order one by one such that, after each removal, the complex is always a ball. Recall the regular cell and corresponding truss block from Figure 3.1, and the proframed simplicial complex realization of that truss block shown in Figure 3.4. In Figure 3.15 we illustrate a shelling of the boundary of the top complex of that proframing, thus of the boundary of that regular cell; in fact, as we will see in the construction, that shelling is obtained inductively via shelling each layer of the proframed complex in turn.

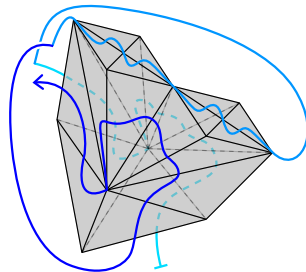

FIGURE 3.15. A shelling of a regular cell boundary.

OUTLINE. In Section 3.3.1, we introduce the section–spacer dichotomy for framed cells, and describe for any framed cell an associated integral proframed cell tower. In Section 3.3.2, we construct the gradient functor from closed trusses to collapsible framed cell complexes, via in particular a proof that the component truss blocks are shellable, and we present the converse integral functor from collapsible framed cell complexes to closed trusses. Finally in Section 3.3.3, we assemble the proofs of the framed-cell–truss correspondences and record corollaries regarding enumerability and piecewise linearity of framed cells.

3.3.1. Integrating framed regular cells. Recall that a framed regular cell has, forgetting the cellular poset structure, an underlying collapsible framed simplicial complex. By the results of the previous section, that collapsible framed simplicial complex has an associated integral collapsible proframed simplicial complex. What is not, a priori, clear is that the layers of that proframed simplicial complex admit cellular poset structures for which they are framed regular cells, and that the projection maps in the proframed complex are framed cellular maps with respect to those poset structures. In this section we show that that is indeed the situation: any framed regular cell has an associated *integral proframed regular cell*, that is a tower of framed regular cells and framed cellular projections.

SYNOPSIS. We differentiate the cells of an n -framed regular cell into section and spacer cells, and show that every spacer cell has distinguished lower and upper section cells in its boundary. Using the section–spacer dichotomy, we then show that the top simplicial projection of the integral simplicial proframing of a framed regular cell admits the structure of a cellular poset map, and thereby inductively construct an integral proframed regular cell tower for any framed regular cell.

3.3.1.1. ★ Central cell structure. We discuss the distinction of framed cells into *section cells* and *spacer cells*; a spacer cell constitutes a bulk region with lower and upper sections cells in its boundary. (Section and spacer cells are analogous to the section and spacer simplices previously discussed in the context of simplices in proframed simplicial complexes, see [Definition 3.2.38](#).)

Consider an n -framed regular cell (X, \mathcal{F}) ; in a substantive abuse of notation we will not introduce separate notation for the underlying framed simplicial complex of a framed regular cell, and will rely on the reader to distinguish when we are referring to a cellular structure, i.e. to a simplicial complex together with its cellular poset order, or merely to a simplicial complex structure. Recall the framed regular cell (X, \mathcal{F}) gives in particular the following structures: (1) its cellular poset X , (2) the associated ordered simplicial complex NX , (3) the distinct framing-induced order on the unordered simplicial complex NX^{un} ; see [Notation 1.3.27](#) and [Remark 1.3.35](#). Recall further that in illustrations of a framed regular cell, we typically draw the simplicial complex realizing the cellular poset and indicate the order recording the cellular structure by small blue arrows emanating from vertices, and then indicate the framing and its order by frame arrows on edges; see [Figures 1.39](#) and [1.40](#).

The underlying collapsible framed simplicial complex of the framed cell (X, \mathcal{F}) has an associated integral collapsible proframed simplicial complex denoted $\mathcal{P} = \int \mathcal{F} = (p_n, \dots, p_1)$, with $p_i : X_i \rightarrow X_{i-1}$. As before let \perp denote the initial element of the cellular poset X , and write $\perp_{n-1} = p_n(\perp) \in X_{n-1}$ for the image of this initial element in the next simplicial layer. Framed cells are distinguished by the nature of the fibers of the projected element \perp_{n-1} , as follows.

DEFINITION 3.3.1 (Section and spacer cells). An n -framed regular k -cell (X, \mathcal{F}) is called:

- > a **section cell** if the fiber category $\Phi_{\mathcal{F}}(\perp_{n-1})$ is trivial;
- > a **spacer cell** if the fiber category $\Phi_{\mathcal{F}}(\perp_{n-1})$ is isomorphic to the category $(\perp^- \rightarrow \perp \rightarrow \perp^+)$ (by an isomorphism taking the initial element \perp to the middle element of the linear fiber). —

TERMINOLOGY 3.3.2 (Central fiber bounds). For a framed regular cell, we refer to the fiber category $\Phi_{\mathcal{F}}(\perp_{n-1})$ as the ‘central fiber’. When it is a spacer cell, we call the 0-simplices \perp^{\pm} the (upper resp. lower) ‘central fiber bounds’ of the cell. —

EXAMPLE 3.3.3 (Section and spacer cells). In Figure 3.16 we illustrate a 3-framed regular section 2-cell and a 3-framed regular spacer 3-cell. We indicate the cellular poset structure with blue arrows, and highlight the central fiber elements in red. —

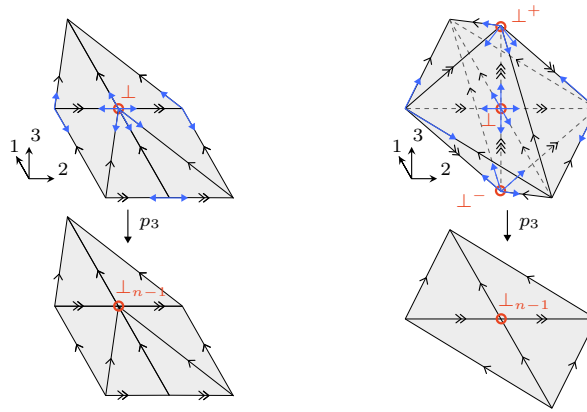

FIGURE 3.16. Framed regular section and spacer cells.

LEMMA 3.3.4 (Framed cells are sections or spacers). *For any n -framed regular k -cell (X, \mathcal{F}) , either the cell is a section, in which case the map $p_n : X_n \rightarrow X_{n-1}$ is an isomorphism of frame-ordered simplicial complexes, or the cell is a spacer.*

PROOF. Since \perp is initial in the poset X , and since fibers over 0-simplices are linear complexes (see Remark 3.2.44), $\Phi_{\mathcal{F}}(\perp_{n-1})$ must have ≤ 3 objects.

- (1) If $\Phi_{\mathcal{F}}(\perp_{n-1})$ has 1 object, we show $p_n : X_n \rightarrow X_{n-1}$ is an isomorphism. This holds iff X_n has no spacer simplices. Arguing by contradiction, let $x : [m] \hookrightarrow X_n$ be a spacer simplex with maximal m . Since \perp is initial in the poset X , \perp must already be a vertex in x . Maximality of m guarantees no other simplex contains x as a face, and so m must equal the dimension k of the cell. As a spacer simplex, x represents a morphism in some fiber category $\Phi_{\mathcal{F}}(z)$ over $z = p_n(x)$. Pick the initial or terminal object in that category, which

represents a $(k-1)$ -simplex y_{\pm} . This simplex must also contain \perp , since $z = p_n(y_{\pm})$. However, y lies in the boundary of the cell $|X|$ and thus so must \perp , which contradicts the assumption that X is a cellular poset with initial object \perp .

- (2) If $\Phi_{\mathcal{F}}(\perp_{n-1})$ has 2 objects, a similar argument applies: note, that one of y_{\pm} contains \perp , and now a spacer simplex must exist. Thus, this case is impossible.
- (3) If $\Phi_{\mathcal{F}}(\perp_{n-1})$ has 3 objects, the fiber category must be of the required form $(\perp_- \rightarrow \perp \rightarrow \perp_+)$; and so the cell is a spacer. \square

CONSTRUCTION 3.3.5 (Upper and lower sections). For an n -framed regular cell (X, \mathcal{F}) , define the frame-ordered simplicial maps $\gamma^{\pm} : X_{n-1} \rightarrow X_n$, called the ‘lower section’ and ‘upper section’ of the cell, as follows: the map γ^{\pm} sends each j -simplex z of the complex X_{n-1} to the j -simplex of the complex X_n that is initial, respectively terminal, in the fiber category $\Phi_{\mathcal{F}}(z)$ over z . —

Note that $\gamma^- = \gamma^+$ exactly when (X, \mathcal{F}) is a section cell. When (X, \mathcal{F}) is a spacer cell, then $\perp^{\pm} \in \text{im}(\gamma^{\pm})$.

We now show that the images of upper and lower sections are exactly the cells with initial elements \perp^{\pm} .

LEMMA 3.3.6 (Section images are cells). *If the framed regular cell (X, \mathcal{F}) is a spacer k -cell, with lower and upper sections γ^{\pm} , then the posets $X^{\geq \perp^{\pm}}$ are regular $(k-1)$ -cells, whose simplices are exactly those in the image of the sections γ^{\pm} .*

PROOF. We argue in the case of the lower section γ^- (the case of the upper section is similar). First observe that any simplex in X containing \perp^- but not \perp is a section simplex for p_n . (Otherwise, we could pick some spacer simplex y containing \perp^- but not \perp . Then there must be some k -simplex y' containing y , which itself is a spacer not containing \perp , and that is impossible.)

We show that $X^{\geq \perp^-}$ is a $(k-1)$ -cell in ∂X . We start by picking some $x \in \partial X$ such that $X^{\geq x}$ is a $(k-1)$ -cell and such that $\perp^- \in X^{\geq x}$. This implies that the framed cell $(X^{\geq x}, \mathcal{F}|_{X^{\geq x}})$ must be a section cell (indeed, $X^{\geq x}$ will contain a $(k-1)$ -simplex containing \perp^- which, as we’ve just observed, must be a section simplex). In fact, each $(k-1)$ -simplex in $X^{\geq x}$ must either contain \perp^- or \perp^+ : this follows, since taking the cone of the section $(k-1)$ -simplices in $X^{\geq x}$ with cone point \perp must yield spacer k -simplices. Observe that $X^{\geq x}$ cannot, however, contain both \perp^- and \perp^+ , without contradicting the collapsibility of the framing \mathcal{F} restricted to $X^{\geq x}$. It follows that all $(k-1)$ -simplices of the $(k-1)$ -cell $X^{\geq x}$ must contain the vertex \perp^- . But this is only possible if $x = \perp^-$.

Finally, we check $\text{im}(\gamma^-)$ contains the same simplices as $X^{\geq \perp^-}$. This follows since any simplex in X_{n-1} lies in a simplex containing \perp_{n-1} . \square

TERMINOLOGY 3.3.7 (Central section cells). Given a spacer cell (X, \mathcal{F}) , we refer to the subposets $X^{\geq \perp^{\pm}}$, determined by the images of the sections

γ^\pm , as the ‘lower central section cell’ resp. ‘upper central section cell’ of (X, \mathcal{F}) . —

3.3.1.2. * Integral proframed cells. Equipped with the dichotomy between section and spacer cells and knowing that a spacer cell has in its boundary lower and upper central section cells, we may now inductively construct cellular structures on the layers of the proframed simplicial complex associated to a framed regular cell.

As in the previous section we fix an n -framed regular k -cell (X, \mathcal{F}) , and consider its associated proframed simplicial complex $\mathcal{P} = \int \mathcal{F} = (p_n, p_{n-1}, \dots, p_1)$, with $p_i : X_i \rightarrow X_{i-1}$. Recall that by definition, for any $x \in X$, the restriction of the framing \mathcal{F} to the subcell $X^{\geq x} \hookrightarrow X$ provides a framed cell $(X^{\geq x}, \mathcal{F}|_{X^{\geq x}})$; in particular, the restriction $\mathcal{F}|_{X^{\geq x}}$ is a collapsible framing.

NOTATION 3.3.8 (The proframing of subcells). For brevity we denote the integral proframed simplicial complex of the subcell $(X^{\geq x}, \mathcal{F}|_{X^{\geq x}})$ by $\mathcal{P}^x = \int (\mathcal{F}|_{X^{\geq x}}) = (p_n^x, p_{n-1}^x, \dots, p_1^x)$, with $p_i^x : X_i^x \rightarrow X_{i-1}^x$. —

OBSERVATION 3.3.9 (Integral restrictions are restricted integrals). From the construction of integral proframings for collapsible framings, it follows that the integral of the restricted framing $\int (\mathcal{F}|_{X^{\geq x}})$ is simply the restriction of the integral $(\int \mathcal{F})|_{X^{\geq x}}$. In particular, the first projection p_n^x of the subcell proframe is the restriction of the global projection p_n to the subcell $X^{\geq x}$. —

LEMMA 3.3.10 (Cellular structure on projected complexes). *For an n -framed k -cell (X, \mathcal{F}) with integral proframe simplicial projection $p_n : X = X_n \rightarrow X_{n-1}$, there exists a unique cellular poset structure on the simplicial complex X_{n-1} such that the projection p_n is a cellular map of regular cells.*

PROOF. If (X, \mathcal{F}) is a section cell, then p_n is a simplicial isomorphism and thus we must have $p_n : X_n \cong X_{n-1}$ as cellular posets.

If (X, \mathcal{F}) is a spacer cell, we define the poset structure on X_{n-1} by identifying $\gamma^- : X_{n-1} \cong X^{\geq \perp^-}$ as posets via γ^- (of course, we could equivalently use γ^+). One checks that $p_n : X = X_n \rightarrow X_{n-1} \cong X^{\geq \perp^-}$ is a cellular poset map, which follows by induction (in the cell dimension k), and using Observation 3.3.9, projecting boundary cells onto their respective lower section cells. □

REMARK 3.3.11 (Isomorphism of lower and upper central section cells). The preceding result provides a cellular poset isomorphism $\gamma^+ \circ p_n : X^{\geq \perp^-} \cong X^{\geq \perp^+}$ between the lower and upper central section cells. —

CONSTRUCTION 3.3.12 (Integral of a framed cell). Applying Lemma 3.3.10 inductively, we obtain a tower of regular cells

$$X = X_n \xrightarrow{p_n} X_{n-1} \xrightarrow{p_{n-1}} \dots \xrightarrow{p_2} X_1 \xrightarrow{p_1} X_0 = [0]$$

(As before we quite abuse notation and level the cell structure implicit.) The proframed simplicial complex $\mathcal{P} = \int \mathcal{F} = (p_n, p_{n-1}, \dots, p_1)$ truncates

to a proframe $\mathcal{P}_{\leq i}$, and the gradient $\mathcal{F}_i := \nabla \mathcal{P}_{\leq i}$ provides a framing of the complex X_i . In fact the cell structure and that framing gives a framed regular cell (X_i, \mathcal{F}_i) , and so we obtain a tower of framed regular cells:

$$(X, \mathcal{F}) = (X_n, \mathcal{F}_n) \xrightarrow{p_n} (X_{n-1}, \mathcal{F}_{n-1}) \xrightarrow{p_{n-1}} \cdots \xrightarrow{p_2} (X_1, \mathcal{F}_1) \xrightarrow{p_1} (X_0, \mathcal{F}_0) = [0]$$

Note that each projection p_i in this cell tower is either a cell isomorphism (if its domain is a section cell) or a cell projection (if its domain is a spacer cell).

TERMINOLOGY 3.3.13 (Integral proframed cell). We refer to the tower of framed cells in the previous construction as the ‘integral proframed cell’ of the framed regular cell (X, \mathcal{F}) .

REMARK 3.3.14 (Integral proframed cell complex). The preceding construction generalizes to the case of collapsible framed regular cell complexes (X, \mathcal{F}) , yielding their associated ‘integral proframed cell complexes’.

EXAMPLE 3.3.15 (Projected framed cell structure). In [Figure 3.17](#) we illustrate the 3-framed 3-globe cell and the induced projection to the 2-framed 2-globe cell that forms the next stage of its integral proframed cell. We emphasize with the green arrows the cellular poset structure on the image 2-complex, provided by [Lemma 3.3.10](#).

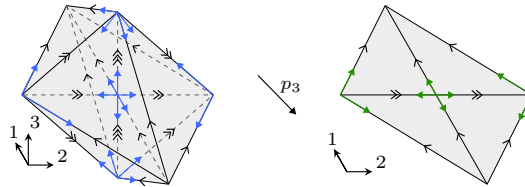

FIGURE 3.17. The projected 2-framed cell of a 3-framed cell.

OBSERVATION 3.3.16 (Highest frame vectors form a framed 1-cell). Given an n -framed k -cell (X, \mathcal{F}) , recall from [Terminology 1.3.52](#) that $\text{axel} \perp$ denotes the subcomplex of the frame-ordered simplicial complex X spanned by the highest frame vectors of the cell. As stated earlier in [Remark 1.3.53](#), provided the cell is not 0-dimensional, this complex $\text{axel} \perp$ is the concatenation of two 1-simplices; that complex corresponds to a cellular subposet of the cellular poset X that is canonically isomorphic to the fundamental poset of a 1-cell.

Given a framed cell (X, \mathcal{F}) , then by [Lemma 3.3.4](#), it is either a spacer cell or a section cell. If it is a spacer cell, then $\text{axel} \perp \cong (\perp^- \rightarrow \perp \rightarrow \perp^+)$ as needed. If it is a section cell, then $\text{axel} \perp \cong \text{axel} \perp_{n-1}$, where \perp_{n-1} is the initial object of the next cell $(X_{n-1}, \mathcal{F}_{n-1})$ in the integral cell tower given in [Construction 3.3.12](#). The observation follows by induction.

3.3.2. Functors between collapsible cell complexes and trusses. Now equipped with a better understanding of the cellular structure of framed regular cells and their associated integral proframed simplicial complexes, we can construct the relevant equivalence functors between collapsible framed cell complexes and closed trusses. At a distance, the translations are clear: framed cell complexes integrate to proframed cell complexes (by the work of the previous section), which then have associated fundamental poset trusses; and trusses realize to proframed simplicial complexes which have associated gradient framed cell complexes. The remaining substantive issue is establishing that the gradient complex of the proframed complex of a truss is in fact cellular. We take the occasion to prove the rather stronger fact that these complexes are locally shellable PL cellular posets.

SYNOPSIS. We construct the gradient functor from closed trusses to collapsible framed cell complexes, by building a proframed simplicial complex from the face orders of the truss and then taking its associated gradient framed simplicial complex; to see that the resulting complex is cellular, we prove that the component truss blocks are pure, shellable, and thin. We then present the converse integral functor from collapsible framed cell complexes to closed trusses, by taking the associated integral proframed cell complex previously constructed and then passing to its fundamental poset truss.

3.3.2.1. ★ From trusses to collapsible cell complexes. We will now construct the ‘gradient cell’ functor from closed n -trusses to collapsible framed regular cell complexes:

$$\nabla_{\mathbb{C}} : \overline{\text{Tr}}_n \rightarrow \text{CollFrCellCplx}_n.$$

We first give the construction on objects, and then separately on morphisms.

CONSTRUCTION 3.3.17 (Gradient cell complexes of closed trusses). Given a closed n -truss $T = (T_n \xrightarrow{p_n} T_{n-1} \xrightarrow{p_{n-1}} \dots \xrightarrow{p_1} T_0)$, we need to produce a collapsible framed cell complex $\nabla_{\mathbb{C}} T = (X, \mathcal{F})$. Recall by definition such a complex is a cellular poset X together with an n -framing \mathcal{F} of its underlying simplicial complex, such that the framed simplicial complex (X, \mathcal{F}) is collapsible and each closed cell $(X^{\geq x}, \mathcal{F}|_{X^{\geq x}})$ is itself a collapsible framed simplicial complex.

By the correspondence, established in [Proposition 3.2.50](#), between collapsible framed simplicial complexes and collapsible proframed simplicial complexes, it suffices to produce a cellular poset X together with a collapsible proframed simplicial complex (X, \mathcal{P}) (beginning with the underlying simplicial complex of the poset X), whose restriction to each closed cell $(X^{\geq x}, \mathcal{P}|_{X^{\geq x}})$ is also collapsible. Explicitly, the desired framing is the gradient $\mathcal{F} := \nabla \mathcal{P}$ of the given proframing.

It furthermore suffices to provide, a priori more, the following: (1) a tower of cellular poset maps

$$X_n \xrightarrow{q_n} X_{n-1} \xrightarrow{q_{n-1}} \dots \xrightarrow{q_2} X_1 \xrightarrow{q_1} X_0$$

together with (2) orderings on the underlying simplicial complexes X_i , with respect to which $\mathcal{P} = (q_n, q_{n-1}, \dots, q_1)$ becomes a proframed simplicial complex, that is (3) collapsible and whose restriction to each closed cell is again collapsible. We now construct in turn (1) that tower and (2) those orderings, and then verify (3) the collapsibility conditions.

(1) We fix the poset X_i to be the face-order truss poset (T_i, \trianglelefteq) , and set the poset map $q_i : X_i \rightarrow X_{i-1}$ to be the projection $p_i : (T_i, \trianglelefteq) \rightarrow (T_{i-1}, \trianglelefteq)$. The heart of the matter is showing that the posets X_i are *cellular*; we excise that to Lemma 3.3.23 below, which will in turn depend on the subsequent Lemmas 3.3.24, 3.3.25, and 3.3.26. That the maps q_i are cellular follows from the fact that 1-truss bundles have lifts in the sense of Observation 2.1.83.

(2) Inductively assume we have defined the order on the simplicial complex X_{i-1} . To provide an order on the simplicial complex X_i , we need to consistently order the vertices of each of the k -simplices $x : [k]^{\text{un}} \hookrightarrow X_i$ in the unordered simplicial complex X_i . To give such a consistent order it suffices to do so for the 1-simplices. Such a 1-simplex x either projects to an object y of X_{i-1} , or else it projects to an (ordered) 1-simplex $z : z(0) \rightarrow z(1)$ in X_{i-1} . In the first case, order $x = x(0) \rightarrow x(1)$ such that $x(0) \prec x(1)$ in the frame order (T_i, \preceq) . In the second case, order x such that its projection to z is order preserving. By construction, the poset map q_i is a simplicial map $q_i : X_i \rightarrow X_{i-1}$ of ordered simplicial complexes, and the collection $\{q_i\}$ forms a proframed simplicial complex.

(3) Recall that the given proframing $\mathcal{P} = (q_n, q_{n-1}, \dots, q_1)$ is collapsible if its fiber categories are linear and the fiber transitions are endpoint-preserving. Since the maps in the proframing are the truss poset projections, those two conditions are exactly the ones verified via truss induction in Observation 2.2.38. Applying that same observation to the 1-truss bundles in each truss block $T^{\triangleright x}$ implies that the cell-restricted proframings $(X^{\geq x}, \mathcal{P}|_{X^{\geq x}})$ are also collapsible, as required. —

CONSTRUCTION 3.3.18 (Gradient cellular maps of singular truss maps). Given a singular n -truss map $F : T \rightarrow S$, we provide the poset map $\nabla_C F : \nabla_C T \rightarrow \nabla_C S$ by setting $\nabla_C F = F_n : T_n \rightarrow S_n$. By the construction of the gradients $\nabla_C T$ and $\nabla_C S$ via proframe towers, we also have a poset map $\nabla_C F_{\leq n-1} : \nabla_C T_{\leq n-1} \rightarrow \nabla_C S_{\leq n-1}$, which by induction we may assume is framed cellular (that is, is a cellular poset map and preserves highest frame vectors). That $\nabla_C F$ is then framed cellular follows by investigating the map $\nabla_C F \rightarrow \nabla_C F_{\leq n-1}$, using that F is singular. —

The crucial matter remains, to prove that the truss posets are cellular. We take a roundabout approach by showing that these posets are moreover *PL cellular*, i.e. that the realizations of the strict upper closure of any element is PL homeomorphic to the standard PL sphere (see Definition 1.3.32). And in fact, along the way we will demonstrate the yet stronger claim that those strict upper closure PL spheres are *shellable*.

We will utilize the following convenient condition for PL cellular sphericity.

PROPOSITION 3.3.19 (See [Bjö84, Prop. 4.5 ff.]). *If a poset X is pure of dimension m , shellable, and thin, then its realization $|X|$ is a regular cell complex that is PL homeomorphic to the PL m -sphere.* \square

TERMINOLOGY 3.3.20 (Pure poset). A simplicial complex is called ‘pure of dimension m ’ if its facets (that is, nondegenerate simplices that are not the face of any other nondegenerate simplex) are all of the same dimension m . Similarly, a poset X is called pure of dimension m if its nerve simplicial complex NX is pure of dimension m . —

TERMINOLOGY 3.3.21 (Shellable poset). A poset X is called ‘shellable’ if the simplicial complex NX is pure of dimension m and its facets admit an ordering $K_0, K_1, K_2, \dots, K_j$, such that, for all $0 < l \leq j$, the subcomplex $(\cup_{i < l} K_i) \cap K_l$ (obtained by intersecting the simplex K_l with the union of the preceding simplices K_i , $i < l$) is a pure simplicial complex of dimension $(m - 1)$. —

TERMINOLOGY 3.3.22 (Thin poset). Finally, a poset X is called ‘thin’ if for every non-refinable length-2 chain $x < y < z$ in X there is exactly one $y' \neq y$ such that $x < y' < z$. (This is also sometimes called the ‘diamond property’.) —

We proceed to the cellularity result.

LEMMA 3.3.23 (Cellularity of closed trusses). *For a closed n -truss T , each face order poset (T_i, \trianglelefteq) is a PL cellular poset.*

PROOF. As the condition of PL cellularity applies to the strict upper closures $T^{\triangleright x}$ of elements, it suffices to assume that the truss T is in fact an n -truss block, with initial element $\perp = x$, and to show that the boundary $\partial T_n = T_n^{\triangleright \perp}$ of the truss block realizes to a PL m -sphere. By Proposition 3.3.19, it is enough to establish that the boundary ∂T_n is pure, shellable, and thin.

Needless to say we proceed by inductively assuming that the boundary ∂T_{n-1} is itself pure (of dimension $k-1$), shellable, and thin. Let $\perp_{n-1} = p_n(\perp)$ denote the projection of $\perp \in T_n$ to T_{n-1} . If the element \perp is singular in the fiber over \perp_{n-1} , then the 1-truss bundle $p_n : T_n \rightarrow T_{n-1}$ is an isomorphism of (face order) posets; thus the boundary ∂T_n is itself pure (of dimension $k-1$), shellable, and thin.

For the case when instead the element \perp is regular, we parcel out the proofs to the following Lemmas 3.3.24, 3.3.25, and 3.3.26. \square

LEMMA 3.3.24 (Truss blocks are pure). *The boundary of every truss block T is of pure dimension.*

PROOF. From discussion in the proof of Lemma 3.3.23, we assume that the boundary ∂T_{n-1} is pure of dimension $k-1$, and that \perp is a regular element over \perp_{n-1} .

Observe that facets of the block T_n project to facets of the block T_{n-1} ; this follows since the projection p_n is surjective on simplices, and the fiber transition maps are also surjective, see [Observation 2.2.38](#). Each facet of T_{n-1} must contain the vertex \perp_{n-1} . Since by assumption the fiber over \perp_{n-1} has spacers, there must also be spacers in the fiber over each facet of T_{n-1} . Thus facets in T_n must themselves be spacers. From the inductive assumption, we know that all facets in T_{n-1} have dimension k , so the facets of T_n have dimension $k + 1$, and thus finally the facets of ∂T_n are of dimension k , as required. \square

◊ Above proof not carefully treated

LEMMA 3.3.25 (Truss blocks are shellable). *The boundary of every truss block T is shellable.*

PROOF. From discussion in the proof of [Lemma 3.3.23](#), we assume that the boundary ∂T_{n-1} is shellable, and that \perp is a regular element over \perp_{n-1} . Initiality of the element \perp implies the fiber $p_n^{-1}(\perp_{n-1})$ must be of the form $\perp^- \triangleright \perp \triangleleft \perp^+$.

Let t_{n-1} be the number of facets in ∂T_{n-1} , and similarly t_n the number of facets in ∂T_n . Consider, by the inductive assumption, a shelling $K_1, K_2, \dots, K_{t_{n-1}}$ order of the facets of ∂T_{n-1} . This order induces a shelling $K_\bullet = (K_1^\perp, K_2^\perp, \dots, K_{t_{n-1}}^\perp)$ of T_{n-1} , where K_i^\perp is obtained from K_i by adjoining a new first vertex \perp_{n-1} . Now build a shelling $L_\bullet = (L_1, L_2, \dots, L_{t_n})$ of ∂T_n in the following three steps.

- (1) *Lower section shelling:* We define the first t_{n-1} facets

$$L_1, L_2, \dots, L_{t_{n-1}}$$

in the sequence L_\bullet , by setting L_i to be the lowest section lying over K_i^\perp . Note that these facets have $L_i(0) = \perp^-$.

- (2) *Side shelling:* We next define the subsequence

$$L_{t_{n-1}+1}, L_{t_{n-1}+2}, \dots, L_{t_n-t_{n-1}}$$

of L_\bullet to be the sequence

$$\begin{aligned} &L_{(1,1)}, L_{(1,2)}, \dots, L_{(1,j_1)}, \\ &L_{(2,1)}, L_{(2,2)}, \dots, L_{(2,j_2)}, \dots, \\ &L_{(t_{n-1},1)}, L_{(t_{n-1},2)}, \dots, L_{(t_{n-1},j_{n-1})} \end{aligned}$$

where $L_{(i,j)}$ is the j th spacer (in the scaffold order!) lying over K_i .

- (3) *Upper section shelling:* Finally, we define the last t_{n-1} facets

$$L_{t_n-t_{n-1}+1}, L_{t_n-t_{n-1}+2}, \dots, L_{t_n}$$

in the sequence L_\bullet by setting $L_{t_n-t_{n-1}+i}$ to be the top section lying over K_i^\perp . Note that these facets have $L_{t_n-t_{n-1}+i}(0) = \perp^+$.

Altogether, this constructs a shelling of ∂T_n . (In [Figure 3.18](#) we illustrate an example of the resulting shelling in the case $n = 2$.) \square

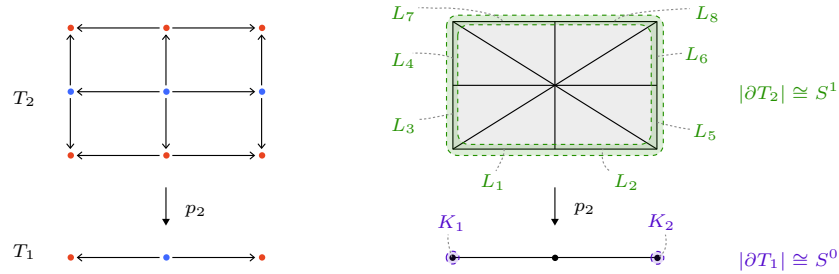

FIGURE 3.18. Inductive shelling of the boundary of a truss block.

LEMMA 3.3.26 (Truss blocks are thin). *The boundary of every truss block T is thin.*

PROOF. From discussion in the proof of Lemma 3.3.23, we assume that \perp is a regular element over \perp_{n-1} . We also assume by induction that the block T_{n-1} is thin. We will show that the block T_n is thin, which implies that the boundary ∂T_n is thin, since the block is the boundary with an initial element adjoined. Consider a 2-simplex $K : [2] \rightarrow T_n$ such that the chain $\text{im}(K) = (x \rightarrow y \rightarrow z)$ is non-refinable. There are two cases, distinguished based on the dimension of the base projection simplex $J : [j] \hookrightarrow T_{n-1}$ with $\text{im}(J) = \text{im}(p_n K)$; either $j = 2$ or $j = 1$.

First assume $j = 2$. Then the base projection J is a chain $(x_{n-1} \rightarrow y_{n-1} \rightarrow z_{n-1})$ in T_{n-1} . Note this chain J must be non-refinable (otherwise, K would be refinable). Thinness of T_{n-1} implies there is exactly one other non-refinable chain $J' : x_{n-1} \rightarrow y'_{n-1} \rightarrow z_{n-1}$. Since the 1-truss bordisms lying over the chain J compose to the same 1-truss bordism as the 1-truss bordisms lying over the chain J' , there must be at least one chain K' from x to z lying over J' . Now, there cannot be a third chain K'' from x to z , since that would have to lie over either J or J' ; assume, without loss of generality, that it lies over J and that $K \prec K''$ in the scaffold order of sections over J ; all spacers over J between K and K'' must now have fiber morphisms in the fiber over y_{n-1} . Thus the 3-spacer containing the 2-section K as its lower section, has a spine that refines K , contradicting that K was non-refinable. It follows that a third chain K'' cannot exist.

Next assume $j = 1$. In this case, the base projection J is a 1-simplex $(x_{n-1} \rightarrow z_{n-1})$ in T_{n-1} . Thus K must be a spacer over J . Arguing by truss induction on the 1-truss bundle p_n over J , we find that exactly two non-refinable chains from x to z must exist. Namely, either the lower or the upper section of K must have a jump morphism that lies over J (this follows from the arguments in the proof of Lemma 2.2.29, or can be seen by thinking of the section order as a directed path through jump morphisms, see Figure 2.31). In the former case the two non-refinable chains are given by the spine of K and the spine of its predecessor, and in the latter case, by the spine of K and the spine of its successor. \square

◇ The above proof has not been seriously scrubbed

3.3.2.2. ★ From collapsible cell complexes to trusses. Conversely to the gradient cell construction in the previous section, we now construction the ‘integral truss’ functor from collapsible framed regular cell complexes to trusses:

$$f_{\mathbb{T}} : \text{CollFrCellCplx}_n \rightarrow \bar{\text{Tr}}s_n$$

We first give the construction on objects, and then briefly mention the case of morphisms. The construction can be relatively succinct because the real work here already happened in the earlier construction of integral proframed cell structures.

CONSTRUCTION 3.3.27 (Integral trusses of collapsible framed cell complexes). Given a collapsible n -framed regular cell complex (X, \mathcal{F}) , we need to produce a closed n -truss $f_{\mathbb{T}}(X, \mathcal{F}) = T = (T_n \xrightarrow{q_n} T_{n-1} \xrightarrow{q_{n-1}} \cdots \xrightarrow{q_1} T_0)$.

Using crucially [Construction 3.3.12](#) and its generalization [Remark 3.3.14](#), construct the integral proframed cell complex of the framed cell complex (X, \mathcal{F}) ; this entails having cellular posets X_i , cellular poset maps $p_i : X_i \rightarrow X_{i-1}$, and orderings on the simplicial complexes X_i such that the maps p_i are also ordered simplicial and form the proframed simplicial complex $\mathcal{P} = f \mathcal{F} = (p_n, \dots, p_1)$.

We will now define (1) the face-order posets (T_i, \trianglelefteq) and poset maps $q_i : (T_i, \trianglelefteq) \rightarrow (T_{i-1}, \trianglelefteq)$; (2) a dimension functor $\dim : (T_i, \trianglelefteq) \rightarrow [1]^{\text{op}}$; and (3) a frame order (T_i, \preceq) ; and then we verify that (4) the fibers of q_i over objects are closed 1-trusses, and (5) the fibers over morphisms are 1-truss bordisms.

(1) Define the face order poset (T_i, \trianglelefteq) to be the cellular poset X_i , and set the projection $q_i := p_i : X_i \rightarrow X_{i-1}$.

(2) Define $\dim : (T_i, \trianglelefteq) \rightarrow [1]^{\text{op}}$ to map $x \in T_i$ to 0 if $X^{\geq x}$ is a section cell, and to 1 if $X_i^{\geq x}$ is a spacer cell in X_i (see [Definition 3.3.1](#)). Since section cells can only contain other section cells in their closure, this defines a poset map as required.

(3) Define two elements x, y in T_i to be related in the frame order (T_i, \preceq) by $x \prec y$ if and only if they are in the same fiber of q_i and there is a linear subcomplex $x \rightarrow \cdots \rightarrow y$ in the frame-ordered simplicial complex X_i .

(4) Using our characterizations of collapsibility, section, and spacer cells, one checks that the structures \trianglelefteq , \dim , and \preceq restrict on fibers $q_i^{-1}(z)$ over objects z in T_{i-1} , to give closed 1-trusses $T_z = (q_i^{-1}(z), \trianglelefteq, \dim, \preceq)$.

(5) Let $f : z \rightarrow w$ be an arrow in T_{i-1} . Denote by $R : T_z \leftrightarrow T_w$ the functorial relation $q_i^{-1}(f)$ coming from the face order poset T_i . Since the proframing \mathcal{P} is collapsible, it follows that $R \subset (T_z, \preceq) \times (T_w, \preceq)$ is bimonotone. Since the fiber transition functors are surjective, it follows that R fully relates elements (and thus preserves singular endpoints). Moreover, if $x \in \text{sing}(T_z)$ there is a unique $y \in \text{sing}(T_w)$ such that $R(x, y)$: indeed, the projection p_i restricts on section cells $X^{\geq x}$ to poset isomorphisms $p_i : X^{\geq x} \cong X^{\geq z}$, and

thus $R(x, y)$ holds if and only if $X^{\geq y} = p_i^{-1}(X^{\geq w})$. The statement that the relation R is a 1-truss bordism now follows from Corollary 2.1.66. \square

CONSTRUCTION 3.3.28 (Integral truss maps of framed cellular maps). Given a framed cellular map $F : (X, \mathcal{F}) \rightarrow (Y, \mathcal{G})$ of collapsible framed regular cell complexes, we construct the singular truss map $f_{\top} F : f_{\top}(X, \mathcal{F}) \rightarrow f_{\top}(Y, \mathcal{G})$. The i th truss component of $f_{\top} F$ is defined to be the i th component of the integral proframed simplicial map $f F$ of the framed simplicial map associated to the cellular map F . The resulting truss map $f_{\top} F$ is singular, i.e. maps singular objects to singular objects, because in fact the simplicial map F_i sends section cells in $(X_i, \nabla((f_{\top} \mathcal{F})_{\leq i}))$ to section cells in $(Y_i, \nabla((f_{\top} \mathcal{G})_{\leq i}))$. \square

◊ Did not check, or scrubbed, the above proof, particularly the end.

3.3.3. Equivalences of framed cell and truss structures. Finally, we can record that truss integration and cell gradient assemble into the following equivalences of categories.

PROOF OF THEOREM 3.1.1 AND THEOREM 3.1.2. Given the functors $\nabla_{\mathbb{C}} : \overline{\text{Tr}}_n \rightarrow \text{CollFrCellCplx}_n$ and $f_{\top} : \text{CollFrCellCplx}_n \rightarrow \overline{\text{Tr}}_n$ defined in the preceding sections, observe that there are unique natural isomorphisms $\text{id} \cong f_{\top} \circ \nabla_{\mathbb{C}}$ and $\text{id} \cong \nabla_{\mathbb{C}} \circ f_{\top}$. (Cf. the rigidity of natural transformations of trusses from Lemma 2.3.71.) Furthermore this equivalence restricts to an equivalence of the subcategories $\text{FrCell}_n \hookrightarrow \text{CollFrCellCplx}_n$ and $\text{Blk}_n \hookrightarrow \overline{\text{Tr}}_n$. \square

PROOF OF THEOREM 3.1.3. We have an equivalence between the categories of framed regular cells FrCell_n and of truss blocks Blk_n , and we want an equivalence between the categories of framed regular cell complexes and of regular block complexes. Regular block complexes are by definition ‘regular presheaves’ on the category of blocks (and their injections); here regularity demands that each block maps injectively into the complex. It remains only to observe that framed regular cell complexes can be recast as regular presheaves on the category of framed regular cells (and their inclusions); again regularity demands that each cell maps injectively into the complex. \square

Of course, we could have considered more general classes of not-necessarily-regular presheaves on framed cells and truss blocks.

Recall that regular cells are algorithmically unrecognizable among posets, and so in particular it is impossible to decidablely enumerate regular cells (cf. Section 1.3.2.5). These computability issues evaporate in the framed context, in the following sense.

COROLLARY 3.3.29 (Framed regular cells are decidablely enumerable). *There is an algorithm for decidablely enumerating framed regular cells among all framed posets.*

◊ The above construction remains sketchy / pushing things under the rug

PROOF. By virtue of their inductive combinatorial definition, we can certainly exhaustively enumerate truss blocks up to a given bound on the size of their underlying poset. By [Theorem 3.1.1](#), we can therefore decidably enumerate framed regular cells. \square

REMARK 3.3.30 (Efficient enumeration of blocks and framed cells). Unlike for instance convex polytopes, which are only enumerable by an exceptionally expensive search, the enumeration of truss blocks is quite efficient in the size of the truss. \square

Finally, let us record a consequence, anticipated back in [Remark 1.3.72](#), of the fact that the boundaries of truss blocks are shellable posets—namely that the notions of cellular and PL cellular coincide in the context of framed regular cells.

COROLLARY 3.3.31 (Framed regular cell complexes are piecewise linear). *For any n -framed regular cell complex (X, \mathcal{F}) , the cellular poset X is PL cellular, and every cell $X^{\geq x}$ and its boundary $X^{>x}$ are shellable.*

PROOF. By [Construction 3.3.27](#), we know the cellular poset of our framed regular cell complex is the face poset of the corresponding closed truss. And by [Lemma 3.3.23](#), we know that the face poset of a closed truss is PL cellular. Any cell $X^{\geq x}$ inherits a framed regular cell structure, thus corresponds to a truss block, whose boundary, and therefore also the whole block, is shellable by [Lemma 3.3.25](#). \square

CHAPTER 4

Constructible framed topology: meshes

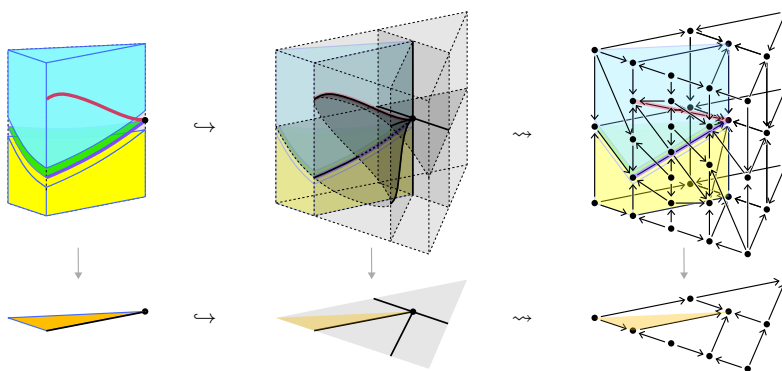

In this chapter, we develop the theory of meshes. Meshes are iterated constructible stratified bundles of framed stratified intervals. In [Chapter 2](#), we introduced the combinatorial counterpart, namely trusses, as iterated constructible bundles of framed fence posets. The stratified geometric realization of a truss is a mesh, and conversely the stratified fundamental poset of a mesh is a truss. Those geometric realization and fundamental poset operations constitute an equivalence of the combinatorial and geometric theories, and so in particular provide a combinatorial model of the local structures of constructibly framed stratified spaces. As an application, leveraging the equivalence of truss blocks and framed regular cells from [Chapter 3](#), we obtain a constructive classification of framed subdivisions of framed regular cells. In the subsequent [Chapter 5](#), we introduce tame stratifications, as the comprehensive class of stratifications that are refinable by a mesh, and prove that all tame stratifications are combinatorially classified by stratified trusses.

The first half of this chapter, namely [Section 4.1](#), introduces 1-meshes, 1-mesh bundles, and n -meshes. The second half of this chapter, namely [Section 4.2](#), builds the fundamental truss of a mesh and the mesh realization of a truss, proves that those constructions are inverse equivalences, and discusses applications thereof.

4.1. 1-Meshes, 1-mesh bundles, and n -meshes

Arbitrary stratifications, even after imposing strong local regularity properties, and even after restricting attention to stratifications of euclidean space, are drastically and uncontrollably complicated. Needless to say at this point, one would like to identify a tractable class of stratifications of euclidean space, that on the one hand can be combinatorially classified, and on the other hand are sufficiently general. Here by ‘sufficiently general’ we mean, for instance, that they coarsen to a class of stratifications that encodes all topological phenomena we might reasonably care about in a finitary context. Our fundamental contention is that such a tractable class is obtained by insisting that the stratifications behave well with respect to the standard framing of euclidean space, where by ‘standard framing’ we really mean a complete flag of foliations by standard euclidean subspaces, and where by ‘behave well’ we mean that the stratification projects along the foliations, constructibly and inductively, to a stratification of the same type in lower dimension.

We already have, of course, a reasonable class of stratifications of 1-dimensional euclidean spaces, namely finite stratifications by points and open intervals, i.e. by contractible submanifolds without boundary. Such a stratification of the euclidean space \mathbb{R}^1 , or more generally a connected submanifold thereof or yet more generally of another manifold framed by an embedding in \mathbb{R}^1 , is the essence of the notion of a *1-mesh*. An example 1-mesh is illustrated on the lower left in [Figure 4.1](#); this open interval in \mathbb{R}^1 is stratified by two point strata and three open interval strata.

The decisive subtleties arise in considering stratified families of such euclidean stratifications. We certainly want to restrict attention to stratified bundles of 1-mesh stratifications, but that by itself is insufficient to provide a controllably iterable theory. We insist then that the boundaries of the fiber 1-meshes vary continuously in the base, and, critically, that the bundle is *constructible* in the sense that, roughly speaking, entrance paths in the base stratification lift uniquely to singular entrance paths in the total stratification. Such a continuous, constructible stratified bundle of 1-meshes will be called a *1-mesh bundle*. An example 1-mesh bundle is illustrated, for instance, by the left map in [Figure 4.1](#); the fiber 1-meshes are closed intervals, stratified by two or three points and one or two open intervals, with the point strata constructibly wandering as indicated.

The crucial, if swift and obvious, maneuver of the whole theory is iterating this operation: consider a 1-mesh bundle over a 1-mesh bundle over a 1-mesh bundle over \dots a 1-mesh. Such a sequence defines our concept of *n -mesh*. Seen, not as built up by bundles on bundles from the base 1-mesh, but conversely and as advertised from the perspective of the total stratification, an *n -mesh* is a stratification in (or suitably embedded in) n -dimensional euclidean space that projects constructibly, with fiber 1-meshes, to an $(n - 1)$ -mesh stratification in $(n - 1)$ -dimensional euclidean space. An example

3-mesh is illustrated by the whole of Figure 4.1; the 1-mesh fibers of the top projection are generically closed intervals but degenerate to point fibers along the left and right seams.

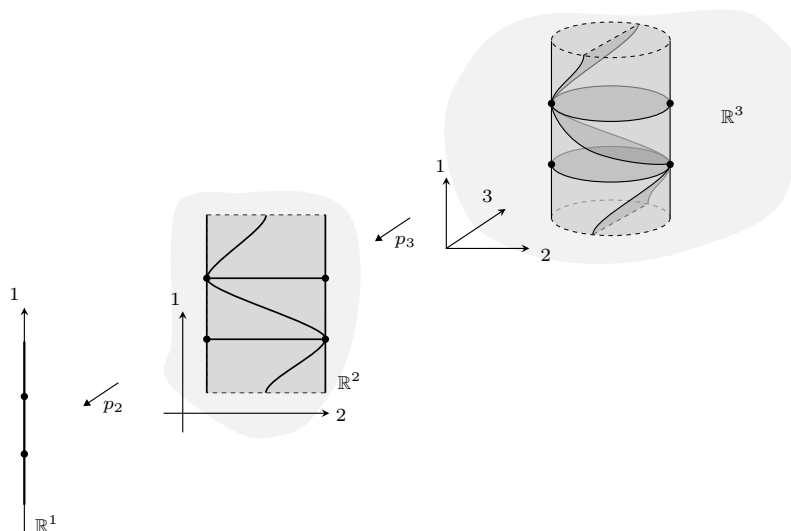

FIGURE 4.1. A 3-mesh.

OUTLINE. In Section 4.1.1, we describe 1-framed realizations of manifolds into standard 1-dimensional euclidean space, and define 1-meshes as finitely stratified manifolds with 1-framed realizations. In Section 4.1.2, we then introduce 1-mesh bundles as boundary-continuous, constructible stratified bundles of 1-meshes, and illustrate various local phenomena in 1-mesh bundles. Finally in Section 4.1.3, we define n -meshes as towers of 1-mesh bundles, discuss maps of such towers, and present the resulting categories and ∞ -categories of meshes and their maps.

4.1.1.1. 1-Meshes.

SYNOPSIS. We introduce 1-framed realizations of manifolds as embeddings into standard 1-framed 1-manifolds. We then define 1-meshes as stratified manifolds with a 1-framed realization, and distinguish linear, circular, and trivial 1-meshes. Finally we describe maps of 1-meshes, as those respecting both the stratification and the framing, delineate the notions of singular, regular, and balanced maps, and define submeshes and degeneracies and coarsenings of meshes.

4.1.1.1.1. 1-Framed realizations. Classically, a tangential framing of a smooth manifold is a trivialization of the tangent bundle. When the manifold does not have a smooth structure, we can ask instead for a trivialization of the tangent microbundle. Whether we work in the smooth or topological category, any sufficiently nice codimension- k embedding (or immersion) of a manifold

M , into a framed target n -manifold, induces a framing of the k -stabilized tangent (micro)bundle of M ; we call such a map a *framed realization*.

In the case of 1-dimensional manifolds, we will focus on the following standard targets, endowed with their respective standard framings.

TERMINOLOGY 4.1.1 (Standard 1-framed target manifolds). The ‘standard 1-framed euclidean space’ is the standard real line \mathbb{R} , equipped with its positive orientation. The ‘standard 1-framed circle’ is the standard circle $S^1 \subset \mathbb{C}$, equipped with its counterclockwise orientation. —

CONVENTION 4.1.2 (Manifolds are topological). Unless mentioned otherwise, the term ‘manifold’ will mean connected topological manifold, with or without boundary. —

DEFINITION 4.1.3 (1-Framed realizations of manifolds). We distinguish two types of 1-framed realizations, as follows:

- › A **1-framed linear realization** of a manifold M is an embedding $\gamma : M \rightarrow \mathbb{R}$.
- › A **1-framed circular realization** of a manifold M is a homeomorphism $\gamma : M \rightarrow S^1$. —

The pair (M, γ) , consisting of a manifold M and a 1-framed (linear or circular) realization γ , will be called a ‘1-framed realized manifold’, or simply a ‘1-realized manifold’, for short.

TERMINOLOGY 4.1.4 (Support and boundedness of realizations). Given a 1-framed linearly realized manifold (M, γ) , we refer to $\gamma(M) \subset \mathbb{R}$ as the ‘support’ of M . We call the realization ‘bounded’ if the support is a bounded subset of \mathbb{R} . —

TERMINOLOGY 4.1.5 (Normal versus tangential framings). For a 1-realized manifold (M, γ) , we refer to the structure provided by the 1-framed realization differently depending on the dimension:

- › When $\dim(M) = 0$, we say that M obtains a ‘normal 1-framing’ from the target standard framed \mathbb{R} .
- › When $\dim(M) = 1$, we say that M obtains a ‘tangential 1-framing’ from the target \mathbb{R} or S^1 . —

REMARK 4.1.6 (Framed realizations up to homotopy). For a 1-manifold M , the space of linear or circular 1-realizations of M (as a subspace of $\text{Map}(M, X)$, for X either \mathbb{R} or S^1) is homotopy equivalent to \mathbb{Z}_2 . That is, up to homotopy there are exactly two 1-framed realizations of any 1-manifold. —

Next we may consider *framed maps* between framed realized manifolds, as maps that preserve the frame structure of the realization target, in the following sense.

TERMINOLOGY 4.1.7 (Framed maps of standard framed targets). For X and Y both being either \mathbb{R} or S^1 , a ‘framed map’ $F : X \rightarrow Y$ is an orientation

preserving map. (More generally, we may allow either source or target to be a connected 1-dimensional submanifold of \mathbb{R} .) Concretely, we have the following cases.

- > A framed map $F : \mathbb{R} \rightarrow \mathbb{R}$ is a monotone map.
- > A framed map $F : \mathbb{R} \rightarrow S^1$ is a map of the form $x \mapsto e^{i\phi(x)}$, where $\phi : \mathbb{R} \rightarrow \mathbb{R}$ is monotone.
- > A framed map $F : S^1 \rightarrow S^1$ is a map of the form $e^{ix} \mapsto e^{i\phi(x)}$, where $\phi : \mathbb{R} \rightarrow \mathbb{R}$ is monotone.
- > A framed map $F : S^1 \rightarrow \mathbb{R}$ is a constant map. —

DEFINITION 4.1.8 (Framed maps of 1-realized manifolds). Given 1-framed realized manifolds (M, γ) and (N, ρ) , a **framed map of 1-realized manifolds** is a map $F : M \rightarrow N$ that induces a framed map $F : \gamma(M) \rightarrow \rho(N)$ of the realization images. —

4.1.1.2. The definition of 1-meshes. A 1-mesh is a suitably stratified 1-framed manifold, as follows.

DEFINITION 4.1.9 (General 1-meshes). A **1-mesh** (M, f, γ) is a manifold M , with a finite stratification f whose strata are manifolds without boundary, and a 1-framed realization γ . —

◇ Could use some more words here, cf truss section

TERMINOLOGY 4.1.10 (Linear, circular, and trivial 1-meshes). A 1-mesh (M, f, γ) is called ‘linear’ when γ is linear, and ‘circular’ when γ is circular; it is called ‘trivial’ when the stratification has a single stratum. —

TERMINOLOGY 4.1.11 (Closed and open 1-meshes). A linear 1-mesh (M, f, γ) is called ‘closed’ or ‘open’ when the image $\gamma(M) \subset \mathbb{R}$ is closed or open, respectively, as a subspace of \mathbb{R} . —

EXAMPLE 4.1.12 (1-Meshes). In Figure 4.2, we illustrate 1-meshes of various types. In each case, we color the 0-dimensional strata in red, and the 1-dimensional strata in blue. For linear 1-meshes, we depict the euclidean space target \mathbb{R} of the realization; later on, we will omit illustration of that target, and instead include a small purple ‘coordinate arrow’, indicating the orientation direction of the realization target. Similarly, we indicate the realization of circular meshes by an arrow giving the orientation of the realization target S^1 . Note that the figure distinguishes three types of trivial 1-meshes: the trivial 0-dimensional mesh, the trivial linear 1-dimensional mesh, and the trivial circular 1-dimensional mesh.²⁶ —

Though much of the theory of meshes can be developed in parallel for the linear and circular cases, our concern will be (as in the case of 1-trusses)

²⁶By contrast, we had distinguished only two trivial 1-trusses in Figure 2.4. This discrepancy indicates that the trivial 1-truss, whose element is of dimension 1, should have two distinct combinatorial incarnations: the ‘trivial linear’ and the ‘trivial circular’ 1-truss. We will not bother rectifying the combinatorial situation to accommodate this distinction, since we are ultimately interested predominately in the linear case.

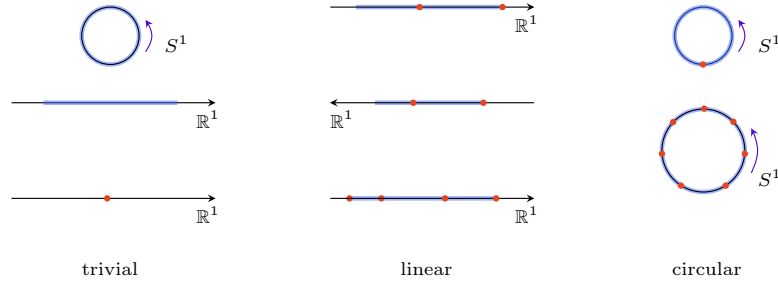

FIGURE 4.2. Trivial, linear, and circular 1-meshes.

almost exclusively with the linear case, and we therefore adopt the following convention.

CONVENTION 4.1.13 (Linear 1-meshes by default). Henceforth, we will use the term ‘1-meshes’ to mean ‘linear 1-meshes’ unless otherwise noted. \square

Moreover, it will be technically convenient to, and we will, assume that all our linear realizations are bounded. Note that we can always obtain a bounded linear realization from a general linear realization by post-composing with a bounded framed embedding $\mathbb{R} \hookrightarrow \mathbb{R}$.

CONVENTION 4.1.14 (Bounded linear realizations by default). We will assume that the realization of any linearly realized 1-mesh (M, f, γ) is bounded. \square

NOTATION 4.1.15 (Realization bounds). For a 1-mesh (M, f, γ) with realization $\gamma : M \hookrightarrow \mathbb{R}$, we refer to the lower and upper bounds of the subspace $\gamma(M) \subset \mathbb{R}$ as the ‘lower realization bound’ γ^- and ‘upper realization bound’ γ^+ . \square

REMARK 4.1.16 (Contractible choice of equivalent 1-realizations). We say two 1-realizations of a manifold are ‘framed homeomorphic’ if they differ by post-composition with a framed homeomorphism of \mathbb{R} . The theory of 1-meshes could be developed by taking only a framed homeomorphism class of 1-realizations (rather than a specific 1-realization) to be part of the data of the 1-mesh. Indeed, for a given 1-mesh (M, f, γ) , the space of 1-realizations framed homeomorphic to the given 1-realization is contractible. \square

4.1.1.3. Maps of 1-meshes. A map of 1-meshes preserves both the stratification and the framing, as follows. Recall the notion of framed map from Definition 4.1.8.

DEFINITION 4.1.17 (Maps of 1-meshes). A **map of 1-meshes** $F : (M, f, \gamma) \rightarrow (N, g, \rho)$ is a continuous map $F : M \rightarrow N$ that is both a stratified map $F : (M, f) \rightarrow (N, g)$ and a framed map $F : (M, \gamma) \rightarrow (N, \rho)$. \square

Corresponding to our earlier definitions of ‘singular’, ‘regular’, and ‘balanced’ maps of 1-trusses (see [Definition 2.1.17](#)), we have the following terminology for maps of 1-meshes.

DEFINITION 4.1.18 (Singular, regular, and balanced maps of 1-meshes).

Let $F : (M, f, \gamma) \rightarrow (N, g, \rho)$ be a map of 1-meshes.

- › The map F is **singular** if it maps point strata to point strata.
- › The map F is **regular** if it maps interval strata to interval strata.
- › The map F is **balanced** if it is both singular and regular. —

Furthermore, in parallel with our earlier definitions of ‘subtruss’, ‘degeneracy’, and ‘coarsening’ of 1-trusses (see [Terminology 2.3.61](#) and [Terminology 2.3.63](#)), we have the following properties of mesh maps.

TERMINOLOGY 4.1.19 (Submeshes of 1-meshes). A map of 1-meshes $F : (M, f, \gamma) \rightarrow (N, g, \rho)$ is called a ‘submesh’ when $F : (M, f) \rightarrow (N, g)$ is a substratification (see [Definition B.2.6](#)). —

TERMINOLOGY 4.1.20 (Degeneracies and coarsenings of 1-meshes). A map of 1-meshes $F : (M, f, \gamma) \rightarrow (N, g, \rho)$ may be of one of the following types.

- › The 1-mesh map F is called a ‘degeneracy’ when it is surjective, singular, and maps each interval stratum either homeomorphically onto its image stratum or to a point stratum.
- › The 1-mesh map F is called a ‘coarsening’ if it is a coarsening of stratifications $F : (M, f) \rightarrow (N, g)$ (see [Definition B.2.4](#)). (Note that coarsenings are necessarily surjective regular 1-mesh maps, and homeomorphisms of underlying spaces by definition.) —

EXAMPLE 4.1.21 (Maps of 1-meshes). In [Figure 4.3](#), in the first row, we depict a singular, a regular, and a balanced map of 1-meshes. In the second row, we depict a degeneracy, a coarsening, and a submesh (which are, respectively, themselves singular, regular, and balanced maps by definition). In the third row, the map is a ‘mixed’ 1-mesh map, which is neither singular nor regular. —

4.1.2. 1-Mesh bundles.

SYNOPSIS. We introduce families of 1-meshes as stratified bundles whose fibers are 1-meshes, together with parametrized 1-framed realizations. We then define 1-mesh bundles as families of 1-meshes satisfying a boundary continuity condition and a constructibility condition. We illustrate various local phenomena that occur in 1-mesh bundles, along with an assortment of families of 1-meshes that fail to be 1-mesh bundles, due to disparate failures of continuity or constructibility. Next we briefly describe maps of 1-mesh bundles, along with pullback and compactification constructions. Finally, we show that cellularity and cellulability properties lift from the base to the total stratifications of 1-mesh bundles.

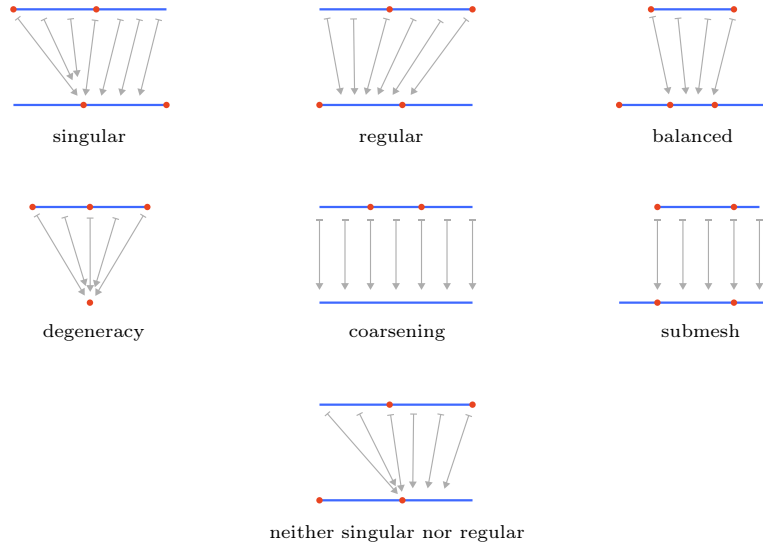

FIGURE 4.3. Types of maps of 1-meshes.

4.1.2.1. 1-Framed realizations of families. As defined, a 1-mesh is a stratified manifold with a 1-framed realization. We now describe a notion of 1-framed realization parametrized by a stratified base space, and use that notion to define parametrized families of 1-meshes. For brevity we adopt the following convention.

CONVENTION 4.1.22 (Finiteness). We henceforth assume all stratifications are finite, i.e. have finitely many strata, unless otherwise noted. \square

DEFINITION 4.1.23 (1-Framed realizations of manifold families). Given a ‘family of manifolds’ $p : M \rightarrow B$ indexed by a space B (meaning that p is a continuous map and each fiber $p^{-1}(b)$, $b \in B$, is a manifold), a **1-framed realization** of the family is a bundle embedding $\gamma : M \hookrightarrow B \times \mathbb{R}$ into the trivial bundle $\pi : B \times \mathbb{R} \rightarrow B$ (i.e. an embedding such that $\pi \circ \gamma = p$). \square

Recall from Definition B.2.24 that a stratified bundle is a stratified map that is a locally trivial bundle within each stratum of the base.

DEFINITION 4.1.24 (Family of 1-meshes). A **family of 1-meshes** $(p, \gamma) : (M, f) \rightarrow (B, g)$, indexed by the stratified space (B, g) , is a stratified bundle $p : (M, f) \rightarrow (B, g)$, together with a 1-framed realization γ of the underlying family of manifolds $p : M \rightarrow B$, such that the stratification f and the realization γ restrict to give every fiber $(M_b := p^{-1}(b), f_b, \gamma_b)$ the structure of a 1-mesh. \square

NOTATION 4.1.25 (Realization bounds for families). For a family of 1-meshes $(p, \gamma) : (M, f) \rightarrow (B, g)$, we denote by $\gamma^\pm : B \rightarrow B \times \mathbb{R}$ the (not necessarily continuous) functions given by the fiberwise lower and upper

realization bounds $b \mapsto (b, \gamma_b^\pm)$ (see Notation 4.1.15). (Abusing notation we let γ^\pm also refer to the composite $B \rightarrow B \times \mathbb{R} \rightarrow \mathbb{R}$.) \square

Consider a stratified bundle $p : (E, f) \rightarrow (B, g)$ such that any stratum of f intersects each fiber $p^{-1}(b)$ in a manifold. Note that, for a given stratum s of f , the dimension of the fiber $s \cap p^{-1}(b)$ is, when nonempty, independent of which fiber is considered. We refer to that dimension as the ‘fiber dimension’ of the stratum. In a family of 1-meshes, each stratum of the family has fiber dimension 0 or 1; we distinguish the strata as singular or regular accordingly.

TERMINOLOGY 4.1.26 (Regular and singular strata). For a family of 1-meshes, we call a stratum of the total space **singular** when its fiber dimension is 0, and we call it **regular** when its fiber dimension is 1. \square

4.1.2.2. The definition of 1-mesh bundles. 1-Mesh bundles will be particularly well-behaved families of 1-meshes, namely those whose realization bounds are continuous and whose stratified bundle is *constructible* in an appropriate sense. The constructibility condition will be formulated in stratified-topological terms, but, leveraging later results of Section 4.2, it will be the case that the stratified-topological constructibility condition implies constructibility in the usual categorical sense, namely that bundles can be constructed by pullback along functors into a suitable classifying category.

To formulate the constructibility condition for 1-mesh bundles, we recall the notions of formal entrance paths and fundamental posets of stratifications.

TERMINOLOGY 4.1.27 (Fundamental posets of stratifications). Given a stratification (X, f) and two strata $r, s \in f$, we say there exists a ‘formal entrance path’ from r to s , when $\bar{r} \cap s$, the intersection of the closure of r with s , is nonempty. The ‘fundamental poset’ $\sqcap(X, f)$ (also written simply $\sqcap f$) is the poset whose objects are the strata of (X, f) , and whose morphisms are the transitive closure of the formal entrance path relation. Note that the fundamental poset provides a functor from the category of stratifications to the category of posets. See Definitions B.1.6 and B.1.10, Construction B.2.15, and surroundings for further discussion of these notions. \square

DEFINITION 4.1.28 (1-Mesh bundles). A **1-mesh bundle** $(p, \gamma) : (M, f) \rightarrow (B, g)$ over a base stratification (B, g) is a family of 1-meshes satisfying the following conditions.

- (1) *Continuity*: The realization bounds $\gamma^\pm : B \rightarrow \mathbb{R}$ are continuous.
- (2) *Constructibility*: For every arrow $r \rightarrow s$ in the fundamental poset $\sqcap(B, g)$, and every lift of the stratum r to a singular stratum t of the total stratification (M, f) , there exists a unique lift of $r \rightarrow s$ to an arrow $t \rightarrow u$ in the fundamental poset $\sqcap(M, f)$ and u is itself singular. \square

Roughly speaking, the constructibility condition ensures that point strata in the fibers behave functionally, during fiber transitions that cover entrance paths in the base. Notice that the condition does not refer to regular strata

at all, but the behavior of those strata is nevertheless constrained by the functionality of their boundary singular strata.

TERMINOLOGY 4.1.29 (Open and closed 1-mesh bundles). A 1-mesh bundle is called ‘closed’ or ‘open’ when all its fibers are, respectively, closed or open 1-meshes. —

EXAMPLE 4.1.30 (A 1-mesh bundle over the stratified 1-simplex). In Figure 4.4, we depict a 1-mesh bundle over the stratified 1-simplex $\| [1] \|$. (The stratified 1-simplex is the stratified realization of the combinatorial 1-simplex; see Section B.1.4.) The fibers over points of the base stratum $[0, 1]$ are open, but the fiber over $\{1\}$ is half-open, and thus the bundle altogether is neither open nor closed.

The fundamental poset of the total stratification of this bundle is the 1-truss bordism previously illustrated in Figure 2.9, and the fundamental poset functor applied to the bundle projection is the projection of that 1-truss bordism, considered as a 1-truss bundle over the combinatorial 1-simplex. —

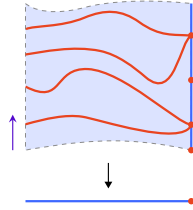

FIGURE 4.4. A 1-mesh bundle over the stratified 1-simplex.

EXAMPLE 4.1.31 (A 1-mesh bundle over a poset realization). In Figure 4.5, we depict a 1-mesh bundle (p, γ) over the stratified realization $(B, g) = \| P \|$ of the poset $P = (a \leftarrow b \leftarrow c \rightarrow d)$. The bundle is drawn together with its 1-framed realization as a subbundle of the projection bundle $B \times \mathbb{R} \rightarrow B$; the orientation of the fiber \mathbb{R} is indicated by an adjacent purple arrow.

Note that the fibers over the points in the stratum $\text{str}(c) \subset \| P \|$ are open 1-meshes, while the fibers over the points of the strata $\text{str}(a)$ and $\text{str}(d)$ are closed 1-meshes, and the fibers over the points of the stratum $\text{str}(b)$ are neither open nor closed. The fundamental poset of this 1-mesh bundle is the 1-truss bundle previously illustrated in Figure 2.19. —

REMARK 4.1.32 (Omitting orientations). When depicting 1-mesh bundles as subbundles of the standard projection bundle $B \times \mathbb{R} \rightarrow B$, we will sometimes forgo indicating an orientation of the fiber \mathbb{R} , as we did for 1-truss bundles, cf. Remark 2.1.82. This omission leaves, of course, a \mathbb{Z}_2 ambiguity, which though is typically without consequence. —

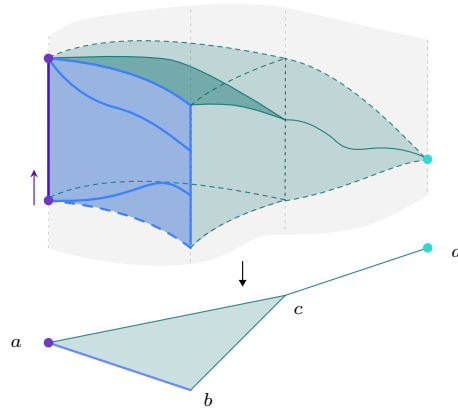

FIGURE 4.5. A 1-mesh bundle over a poset realization.

A general stratified bundle is only locally trivial over each base stratum, and so admits some stratified monodromy. By contrast, due to the rigid nature of their fibers, 1-mesh bundles are in fact globally trivial over each base stratum, as follows.

NOTATION 4.1.33 (Restriction to base strata). Let $p : (M, f) \rightarrow (B, g)$ be a 1-mesh bundle. The restriction of this bundle to a stratum $s \in g$ is a 1-mesh bundle denoted $p|_s : (p^{-1}(s), f) \rightarrow s$. —

OBSERVATION 4.1.34 (Trivialization over base strata). Because the automorphism space of every 1-mesh is contractible, the restricted 1-mesh bundle $p|_s$ (of any 1-mesh bundle p to any base stratum s) is isomorphic to a trivial 1-mesh bundle:

$$\begin{array}{ccc}
 (p^{-1}(s), f) & \xrightarrow{\cong} & s \times \text{fib}(s) \\
 \searrow p|_s & & \swarrow \\
 & s &
 \end{array}$$

Here $\text{fib}(s)$ denotes a 1-mesh, called the ‘fiber 1-mesh’, over the stratum s . —

REMARK 4.1.35 (Mapping cylinders as bundles). Recall from Section 2.1.2.5 that suitable singular 1-truss maps had associated mapping cylinder 1-truss bordisms, and suitable regular 1-truss maps had associated mapping cocylinder 1-truss bordisms. We have an analogous relationship for 1-meshes: the mapping cylinder of a suitable singular 1-mesh map is a 1-mesh bundle over the stratified 1-simplex, and similarly the mapping cocylinder of a suitable regular 1-mesh map is again a 1-mesh bundle over the stratified 1-simplex. These cylinder and cocylinder constructions are discussed later on, in Remark 4.2.6, as a consequence of the constructions in the truss case and the equivalence of meshes and trusses. —

As given above, the constructibility condition for a 1-mesh bundle refers to a lifting condition involving arrows in the fundamental posets; such arrows are generated by the transitive closure of the formal entrance path relations, and the condition is in principle a bit unwieldy as a result. However, with mild assumptions on the behavior of the base stratification, we can refine the constructibility condition as follows.

TERMINOLOGY 4.1.36 (Frontier-constructibility and local path-connectedness). We may impose the following conditions on a stratification (X, f) .

- › The stratification (X, f) is ‘frontier-constructible’ if $(\bar{r} \cap s \neq \emptyset) \Rightarrow (s \subset \bar{r})$ for any two strata $r, s \in f$.
- › The stratification (X, f) is ‘pairwise locally path-connected’ if the union $s \cup r$ is locally path-connected, for any two strata $r, s \in f$.
- › We refer to a stratification as ‘reasonably regular’ if it satisfies both of the preceding conditions. —

In a reasonably regular stratification, the fundamental poset has an arrow $r \rightarrow s$ precisely when there is an entrance path from r to s ; see Lemma B.1.31 and Observation B.1.32. We can therefore, in that case, rephrase the constructibility condition for 1-mesh bundles in terms of entrance paths, as follows.

OBSERVATION 4.1.37 (1-Mesh bundle over a reasonably regular base). Let $(p, \gamma) : (M, f) \rightarrow (B, g)$ be a family of 1-meshes over a reasonably regular base (B, g) . This family is a 1-mesh bundle if it satisfies the ‘continuity’ condition from Definition 4.1.28, as well as the following condition.

- (2') *Path-independent constructibility*: For every entrance path $\alpha : r \rightarrow s$ in the base (B, g) , and every lift of the stratum r to a singular stratum t of the total stratification (M, f) , there exists a unique lift of $\alpha : r \rightarrow s$ to an entrance path $\beta : t \rightarrow u$ in (M, f) and u is itself a singular stratum. Furthermore, the resulting singular stratum u , that is the target of the lifted entrance path β , is independent of which entrance path α from r to s was chosen initially. —

Since eventually we will be considering 1-mesh bundles over 1-mesh bundles iteratively, it is worth noting that if the base stratification of a 1-mesh bundle is reasonably regular, then it follows that the total stratification is also reasonably regular; see later Observations 4.1.67 and 4.1.68. However, various elementary constructions may break reasonable regularity; for instance, restricting the standard stratification of the realized simplex $\| [k] \|$ to its boundary yields a stratification that is not frontier-constructible.

The definition of 1-mesh bundles has a natural generalization, that allows the base to be a category, not just a poset. (This generalization will not play a substantive role later and can be safely skipped.) However, this categorical version requires a stronger regularity condition on the base stratification,

namely ‘conicality’ (see Section B.3.1); conical stratifications are, in particular, reasonably regular. In the following categorical discussion, we will implicitly assume stratifications are conical as needed.

To begin, in place of the fundamental poset of a stratification, we need a notion of the fundamental ∞ -category and fundamental 1-category of a stratification, as follows.

TERMINOLOGY 4.1.38 (Fundamental ∞ -category). The ‘fundamental ∞ -category’ $\mathbb{P}_\infty f$ of a stratification (X, f) is the quasicategory whose n -simplices are the stratified maps $\| [n] \| \rightarrow (X, f)$. —

TERMINOLOGY 4.1.39 (Fundamental 1-category). The ‘fundamental category’ $\mathbb{P}_1 f$ of a stratification (X, f) is the truncation of the fundamental ∞ -category to a 1-category. (See Definition B.3.10 and Construction B.3.14 and the intervening discussion of truncation.) —

Moreover, the fundamental poset $\mathbb{P}f$ of a stratified space (X, f) , given by Terminology 4.1.27, is equivalent to the 0-truncation of the fundamental ∞ -category $\mathbb{P}_\infty f$; see Terminology B.3.12 and Observation B.3.13.²⁷

EXAMPLE 4.1.40 (Base posets versus base categories). In Figure 4.6, in the middle we depict a bundle that is locally a well-behaved 1-mesh bundle. However, it is not a 1-mesh bundle in the sense of Definition 4.1.28, because it fails the constructibility condition; the relevant failure of unique lifts is illustrated on the left. The bundle will be, though, a categorical 1-mesh bundle, in the sense that the constructibility condition will be restored when we consider not the fundamental poset but the fundamental categories of the stratifications; the relevant uniqueness of lifts is illustrated on the right. The necessary categorical notion is formalized in the next remark. (Note that the fundamental category of the total stratification here was illustrated as a categorical 1-truss bundle in Figure 2.20.) —

We are now equipped to describe the anticipated categorical version of 1-mesh bundles.

DEFINITION 4.1.41 (Categorical 1-mesh bundles). A **categorical 1-mesh bundle** $p : (M, f) \rightarrow (B, g)$ is a family of 1-meshes, over a reasonably regular base (B, g) , satisfying the ‘continuity’ condition from Definition 4.1.28, as well as the following condition.

- (2') *Path-dependent constructibility*: For every entrance path $\alpha : r \rightarrow s$ in the fundamental category $\mathbb{P}_1 g$, and every lift of the stratum r to a singular stratum t of the total stratification (M, f) , there exists a unique lift of $\alpha : r \rightarrow s$ to an entrance path $\beta : t \rightarrow u$ in the

²⁷There is a useful analogy that sets are to spaces what posets are to stratified spaces. For instance, the fundamental ∞ -category of a stratified space admits a conservative functor to its (0-truncated) fundamental poset, as the fundamental ∞ -groupoid of a space admits a conservative functor to its (0-truncated) connected component set; see Remark B.3.15.

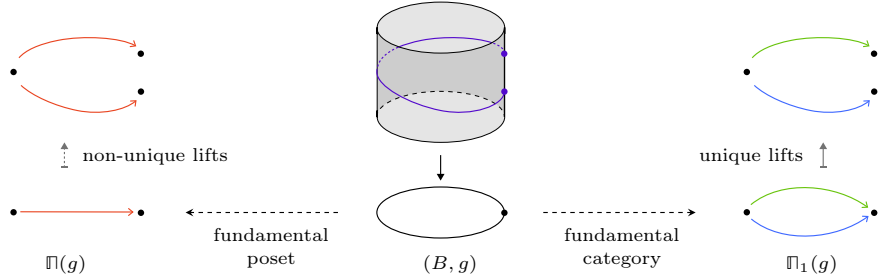

FIGURE 4.6. A categorical 1-mesh bundle.

fundamental category $\mathbb{P}_1 f$, and furthermore u is itself a singular stratum. —

We could have formulated the path-dependent constructibility condition by merely asking every literal entrance path $r \rightarrow s$ in the base stratification (not in the quotient fundamental category) to lift uniquely to a suitable literal entrance path $t \rightarrow u$ in the total stratification. In fact, the resulting notion is unchanged: a homotopy α_t of entrance paths provides a homotopy β_t of lifts, which gives a path of singular strata u_t ; since the fibers in a family of 1-meshes are 1-meshes and therefore have discrete sets of singular points, any such path of singular strata is constant. Henceforth, we will freely work with either version of categorical 1-mesh bundles, as convenient.

To emphasize the distinction from the case of categorical 1-mesh bundles, we sometimes refer to 1-mesh bundles in the sense of Definition 4.1.28 as ‘posetal 1-mesh bundles’. As discussed, the bundle shown in Figure 4.6 is categorical but not posetal.

REMARK 4.1.42 (Categorical versus posetal 1-mesh bundles). Every posetal 1-mesh bundle over a reasonably regular base is, of course, a categorical 1-mesh bundle. Conversely, if the base stratification is posetal, meaning its fundamental ∞ -category is 0-truncated (or, in other words, the stratification is ‘stratified homotopy equivalent’ to the stratified realization of a poset P), then any categorical 1-mesh bundle is in fact posetal. —

We give an explicit statement and proof of the converse implication in that last remark, in the concrete case where the base is a realization of a poset.

PROPOSITION 4.1.43 (Categorical bundles over posets are posetal). *A categorical 1-mesh bundle over the stratified realization of a poset (or a constructible substratification thereof) is a posetal 1-mesh bundle.*

PROOF. Given a poset X with stratified realization $\|X\|$, consider a categorical 1-mesh bundle $p : (M, f) \rightarrow \|X\|$. Let $r \equiv \text{str}(x)$ be a stratum in $\|X\|$ with a lift to a singular stratum t , and let $\alpha : r \rightarrow s$ be an entrance path. Since the stratum r , its closure, the stratum s , and its closure are all contractible, every entrance path $r \rightarrow s$ is homotopic to α and so equivalent

to it in the fundamental category. Thus no matter the entrance path, there is altogether a unique lift to an entrance path $\beta : t \rightarrow u$, and u is singular, as required for a posetal 1-mesh bundle. \square

REMARK 4.1.44 (Classification of categorical 1-mesh bundles). We will later that the posetal constructibility condition in Definition 4.1.28 precisely ensures that posetal 1-mesh bundles over (sufficiently regular) base stratifications (B, g) are classified up to bundle isomorphism by functors $\mathbb{P}g \rightarrow \mathbf{TBord}^1$ from the fundamental poset of the base to the classifying category of 1-trusses and their bordisms.

The categorical case is similar: the categorical constructibility condition in Definition 4.1.41 ensures that categorical 1-mesh bundles are classified up to bundle isomorphism by ∞ -functors $\mathbb{P}_\infty(g) \rightarrow \mathbf{TBord}^1$, and so (since the codomain is a 1-category) by 1-categorical functors $\mathbb{P}_1(g) \rightarrow \mathbf{TBord}^1$. \square

REMARK 4.1.45 (Categorical 1-mesh bundles are higher constructible). Entrance paths are stratified maps from the stratified 1-simplex. The path constructibility condition for a categorical 1-mesh bundle, given in Definition 4.1.41, is thus a lifting condition for the stratified 1-simplex. One might imagine that there is a $(k \in \mathbb{N})$ -indexed family of ‘higher constructibility’ conditions, given by analogous lifting conditions for maps out of the stratified k -simplex. However, in the context of conical stratifications, all those higher constructibility conditions are automatically satisfied by categorical 1-mesh bundles, as defined just with the ‘1-constructibility’ requirement. \square

4.1.2.3. Local phenomena in families of 1-meshes. We describe and illustrate various local phenomena that occur in families of 1-meshes: first examples of families that are indeed 1-mesh bundles, then examples that violate either or both of the continuity and constructibility conditions, to different extents and in sundry ways, and so fail to be 1-mesh bundles.

EXAMPLE 4.1.46 (Local forms of 1-mesh bundles). In Figure 4.7 we illustrate some local behaviors in 1-mesh bundles. The top three are ‘collisions’ in the sense that two singular strata in the generic fiber converge into a single singular stratum of the special fiber. The bottom three are ‘creations’ in the sense that a new singular stratum appears in the special fiber, with no singular stratum of the generic fiber converging to it. The right two are also ‘collapses’ in the sense that the interval of the generic fiber degenerates into a point of the special fiber.

The 1-truss bordisms obtained as the fundamental posets of these 1-mesh bundles were illustrated in Figure 2.12. \square

EXAMPLE 4.1.47 (Families of 1-meshes that are almost continuous and constructible). In Figure 4.8 we illustrate three families of 1-meshes that are not 1-mesh bundles, because they fail one or both of the continuity and constructibility conditions. In the first case, the upper realization bound has an upward discontinuity at the special fiber. In the second case, the upper realization bound has a downward discontinuity at the special fiber; this

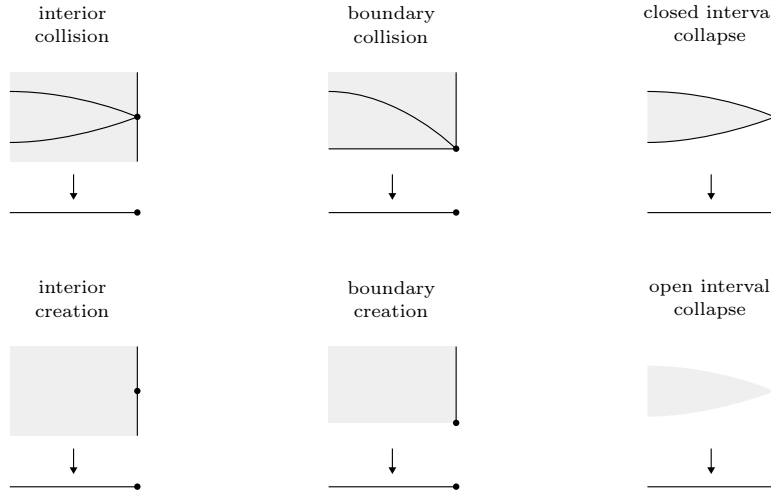

FIGURE 4.7. Local forms of 1-mesh bundles.

case also fails constructibility since the singular stratum of the generic fiber does not converge to any stratum of the special fiber. In the third case, the realization bounds are continuous, but again the generic singular stratum does not converge to any special stratum, and so this case fails constructibility. However, all three of these failures are rather mild in the sense that, in each case, either the generic or special fiber can be extended to resolve the issue; in other words, these families of 1-meshes embed as subfamilies of actual 1-mesh bundles.²⁸

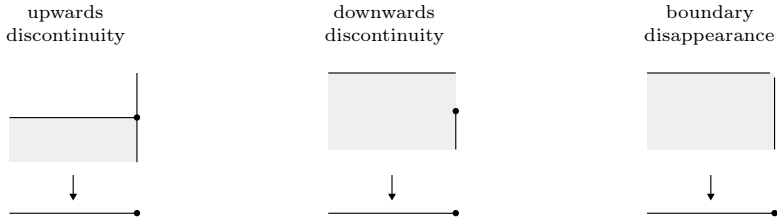

FIGURE 4.8. Mild mesh mishaps of constructible continuity.

The combinatorial counterparts of each of these families, namely the relations obtained by taking fundamental posets, were illustrated in Figure 2.13.

EXAMPLE 4.1.48 (Families of 1-meshes that fail constructible lift existence). In Figure 4.9 we illustrate three families of 1-meshes that are not

²⁸One could enlarge the class of valid 1-mesh bundles to include families that allow certain boundary discontinuities or certain boundary disappearances, but we forego that generalization here.

1-mesh bundles, again because they fail one or both of the continuity and constructibility conditions. In the first case, the generic fiber singular stratum converges, but to a regular stratum of the special fiber, violating constructibility. That same violation occurs in the second case, though with a boundary singular stratum; this case also evidently fails realization continuity. The third case appears to violate constructibility in the same way as the other two cases. However, this case is in fact, in a sense, even worse, because there are two lifts (of the entrance path in the base) starting at the generic fiber singular stratum—namely the entrance path converging to the regular stratum, and the transitive composite of that entrance path and the entrance path into the singular stratum of the special fiber.

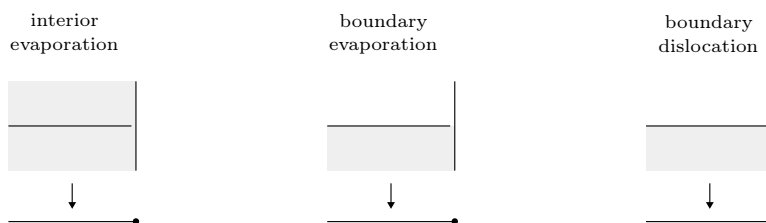

FIGURE 4.9. Lamentable lapses of liftability.

None of these three families are subfamilies of mesh bundles, as the constructibility failure is intrinsic. Nevertheless, one could refine the special fiber by adding a singular stratum inside the regular stratum, in order to obtain either a mesh bundle or a subfamily of a mesh bundle.

The combinatorial counterparts of these families were illustrated earlier, the first two cases as the first two relations in Figure 2.14, and the third case as the first relation in Figure 2.15. └─

EXAMPLE 4.1.49 (Families of 1-meshes with divergent realization bounds). In Figure 4.10 we illustrate two families of 1-meshes that fail both continuity and constructibility in a most serious and irresolvable manner. In both cases, the upper realization bound is not only discontinuous but also fails to have a limit as it approaches the special fiber. Furthermore, in the first case, there are distinct formal entrance paths from the generic fiber singular stratum to all three of the special fiber strata, and in the second case to both of the special fiber strata, contravening constructibility. The second case has a yet more serious pathology, namely that there is a formal entrance path from the generic fiber regular stratum to the special fiber regular stratum, which crosses (in the framing direction) the formal entrance path from the generic fiber singular stratum to the special fiber singular stratum.

The combinatorial counterparts of these families were illustrated earlier, the first case as the last relation in Figure 2.14, and the second case as the last relation in Figure 2.15. └─

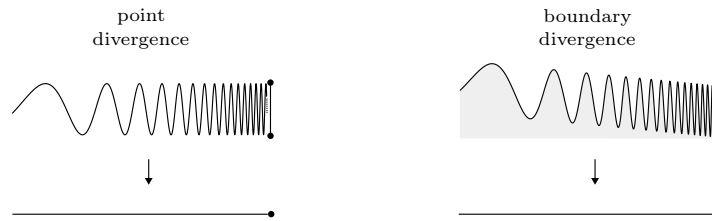

FIGURE 4.10. Brazen breaches of boundaries.

EXAMPLE 4.1.50 (Families of 1-meshes that fail constructible lift uniqueness). In Figure 4.11 we illustrate two families of 1-meshes that fail constructibility in a more subtle, if no less serious, manner. Both families have a conical total stratification and a conical base stratification, and so demonstrate that even in the better-behaved context of conical stratifications, the constructibility condition remains crucial.

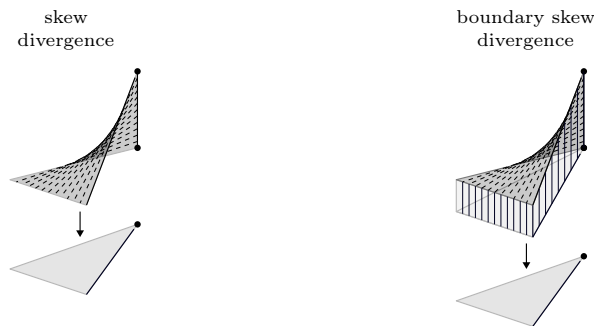

FIGURE 4.11. Subtle skews of mesh lift uniqueness.

These are both families over the stratified 2-simplex. The first case has a stratified closed interval fiber over the 0-simplex, a single stratum over the 1-simplex and a single stratum over the 2-simplex. Though the stratum over the 1-simplex converges uniquely to a singular stratum over the 0-simplex, the (singular) stratum over the 2-simplex admits entrance paths to all three of the strata over the 0-simplex, violating the uniqueness of lifts in the constructibility condition. In the second case, every fiber of the family is the same standard stratified closed interval; when restricted to the 0- and 1-simplex the family is the trivial (in particular, constructible) bundle, and when restricted to the 1- and 2-simplex the family is again the trivial (in particular, constructible) bundle; nevertheless, the entrance paths over the entrance path from the 2- to 0-simplex fail constructibility as in the first case.

The fundamental poset of the first case here contains the fundamental poset of the first case of Figure 4.10 (namely the last relation of Figure 2.14). The fundamental poset of the second case here contains the fundamental posets of both cases of Figure 4.10 (the second of which is the last relation of

Figure 2.15) and also the fundamental poset of the last case of Figure 4.9 (namely the first relation of Figure 2.15); the inherited constructibility failures are pervasive. —

4.1.2.4. Maps of 1-mesh bundles. Maps of 1-mesh bundles are simply stratified bundle maps that restrict to maps of 1-meshes on each fiber, and require little fanfare.

DEFINITION 4.1.51 (Maps of 1-mesh bundles). For 1-mesh bundles $(p, \gamma) : (M, f) \rightarrow (B, g)$ and $(p', \gamma') : (M', f') \rightarrow (B', g')$, a **map of 1-mesh bundles** $F : p \rightarrow p'$ is a stratified map $F : (M, f) \rightarrow (M', f')$ that descends along p and p' to a stratified map $G : (B, g) \rightarrow (B', g')$, such that the restriction of F to each fiber $M_b := p^{-1}(b)$, $b \in B$, is a 1-mesh map $(M_b, f_b, \gamma_b) \rightarrow (M'_{G(b)}, f'_{G(b)}, \gamma'_{G(b)})$. —

TERMINOLOGY 4.1.52 (Singular, regular, and balanced 1-mesh bundle maps). We call a 1-mesh bundle map ‘singular’ or ‘regular’ or ‘balanced’ if it is respectively singular or regular or balanced on every fiber, in the sense of Definition 4.1.18. —

TERMINOLOGY 4.1.53 (Degeneracies and coarsenings of 1-mesh bundles). We call a 1-mesh bundle map a ‘degeneracy’ or ‘coarsening’ when it is such on every fiber, in the sense of Terminology 4.1.20. —

NOTATION 4.1.54 (Implicit realizations). Henceforth, we often keep the 1-framed realization γ of 1-mesh bundles (p, γ) implicit, denoting the 1-mesh bundle by simply $p : (M, f) \rightarrow (B, g)$. —

EXAMPLE 4.1.55 (1-Mesh bundle map). In Figure 4.12, we depict a 1-mesh bundle map, neither singular nor regular as it happens. —

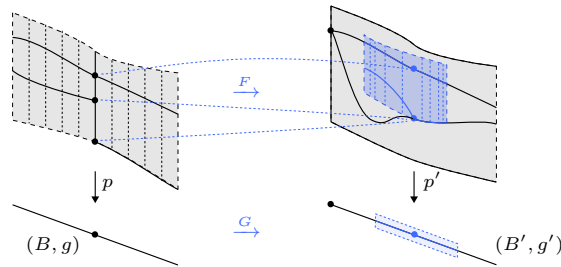

FIGURE 4.12. 1-Mesh bundle map.

REMARK 4.1.56 (Mapping 1-realized bundles). We often think about the total space M of 1-mesh bundle (p, γ) being more or less identified with its embedded image $\gamma(M)$ under its 1-framed realization $\gamma : M \hookrightarrow B \times \mathbb{R}$. That convenient identification is compatible with bundle maps in the sense

that every 1-mesh bundle map $F : (p, \gamma) \rightarrow (p', \gamma')$ induces a commutative diagram of continuous maps as follows:

$$\begin{array}{ccccc}
 & & \pi & & \\
 & \swarrow & & \searrow & \\
 \gamma(M) & \xleftarrow{\gamma} & M & \xrightarrow{p} & B \\
 \tilde{F} \downarrow & & F \downarrow & & \downarrow G \\
 \gamma'(M') & \xleftarrow{\gamma'} & M' & \xrightarrow{p'} & B' .
 \end{array} \quad \text{—}$$

A useful construction in the context of 1-mesh bundle maps is pullback bundles, as follows.

CONSTRUCTION 4.1.57 (Pullbacks of 1-mesh bundles). Given a 1-mesh bundle $p : (M, f) \rightarrow (B, g)$ with 1-framed realization $\gamma : M \hookrightarrow B \times \mathbb{R}$, and a stratified map $G : (B', g') \rightarrow (B, g)$, the ‘pullback 1-mesh bundle’ $(G^*p, G^*\gamma)$ is given as follows. The stratified bundle $G^*p : (G^*M, G^*f) \rightarrow (B', g')$ is the stratified pullback of the bundle p along the map G (see Definition B.2.26):

$$\begin{array}{ccc}
 (G^*M, G^*f) & \xrightarrow{\text{Tot}G} & (M, f) \\
 G^*p \downarrow & \lrcorner & \downarrow p \\
 (B', g') & \xrightarrow{G} & (B, g)
 \end{array}$$

The 1-framed realization $G^*\gamma : G^*M \hookrightarrow B' \times \mathbb{R}$ for G^*p is defined by

$$(G^*\gamma)(x) := ((G^*p)(x), (\pi_{\mathbb{R}} \circ \gamma \circ \text{Tot}G)(x)) \in B' \times \mathbb{R},$$

where $\pi_{\mathbb{R}} : B \times \mathbb{R} \rightarrow \mathbb{R}$ is the projection. —

Another construction of 1-mesh bundle maps is the inclusion of a 1-mesh bundle into its fiberwise compactification, as follows. (This canonical compactification will be particularly pertinent in our later comparison of meshes and trusses, allowing us to reduce certain statements to the case of closed bundles.)

CONSTRUCTION 4.1.58 (Fiberwise compactifications of 1-mesh bundles). Given a 1-mesh bundle $p : (M, f) \rightarrow (B, g)$ with 1-framed realization $\gamma : M \hookrightarrow B \times \mathbb{R}$, the ‘fiberwise compactification’ 1-mesh bundle $\bar{p} : (\bar{M}, \bar{f}) \rightarrow (B, g)$ is given as follows. Set the space \bar{M} to be the closure of $\gamma(M)$ in $B \times \mathbb{R}$, with projection $\bar{p} : \bar{M} \rightarrow B$ being the restriction of $\pi : B \times \mathbb{R} \rightarrow B$ to \bar{M} . The stratification (\bar{M}, \bar{f}) has each stratum being either an image $\gamma(r)$ of a stratum $r \in f$ or an image $\gamma^\pm(s)$ of a stratum $s \in g$. Of course the 1-framed realization $\bar{\gamma} : \bar{M} \hookrightarrow B \times \mathbb{R}$ is simply the inclusion. —

EXAMPLE 4.1.59 (1-Mesh bundle compactification). In Figure 4.13, we depict the compactification \bar{p} of a 1-mesh bundle p over the standard stratified 1-simplex. —

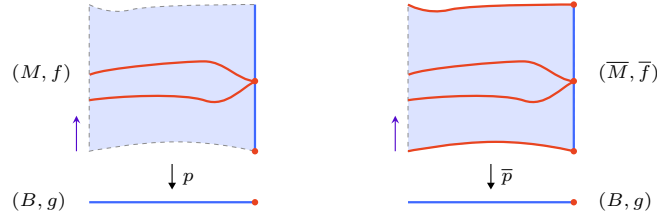

FIGURE 4.13. The compactification of a 1-mesh bundle.

OBSERVATION 4.1.60 (Pullbacks preserve fiberwise compactifications). Consider a 1-mesh bundle $p : (M, f) \rightarrow (B, g)$, together with a stratified map $G : (B', g') \rightarrow (B, g)$. The pullback G^*p of the fiberwise compactification of p is the fiberwise compactification $\overline{G^*p}$ of the pullback G^*p . \square

4.1.2.5. ★ Lifting regularity to total stratifications. When considering 1-mesh bundles, we usually assume that the base stratification satisfies some regularity properties. These regularity properties often ‘lift’ from the base stratification to the total stratification of the bundle, as we will discuss presently. These lifting properties are particularly useful when we begin to iterate 1-mesh bundles.

Eventually, we will be comparing iterated mesh bundles to the purely combinatorial iterated truss bundles; we cannot expect to combinatorialize mesh bundles unless the base stratification is itself combinatorializable. Recall from Section 1.3.1 that regular cell complexes (stratifications by open disks whose closures are closed disks) are faithfully modeled by their fundamental posets, and so are a suitable class of base stratifications. We broaden our attention to stratifications that refine to constructible substratifications (see Definition B.2.8) of regular cell complexes, as follows.

TERMINOLOGY 4.1.61 (Cellular stratifications; see Definition B.3.20). A ‘cellular stratification’ is a constructible substratification of a regular cell complex (stratified by its cells). \square

TERMINOLOGY 4.1.62 (Cellulable stratifications; see Definition B.3.21). A ‘cellulable stratification’ is a stratification that admits a refinement to a cellular stratification. \square

See Section B.3.3 for a more extensive discussion of cellular and cellulable stratifications.²⁹

Cellulability provides a sufficiently broad class of sufficiently combinatorializable and sufficiently regular stratifications; this class admits the following lifting property, as desired.

²⁹In fact, it is often convenient to restrict attention to PL cellular stratifications, i.e. constructible substratifications of regular cell complexes whose fundamental posets are PL cellular, see Definition 1.3.32. However, we will not insist on piecewise linearity as a matter of course.

PROPOSITION 4.1.63 (Cellulability lifts). *Let $p : (M, f) \rightarrow (B, g)$ be a 1-mesh bundle. If the base stratification (B, g) is cellullable then the total stratification (M, f) is as well.*

This property will follow from the liftability of cellularity, as follows.

LEMMA 4.1.64 (Cellularity lifts). *Let $p : (M, f) \rightarrow (B, g)$ be a 1-mesh bundle. If the base stratification (B, g) is cellular then the total stratification (M, f) is too.*

The proof of this lemma will use the following technical observation.

OBSERVATION 4.1.65 (Cells bundled over cells). Let D^m be the closed m -disk, and S^{m-1} its boundary sphere. Let $p : X \rightarrow D^m$ be a subbundle of the projection $\pi : D^m \times \mathbb{R} \rightarrow D^m$, whose fibers over $x \in D^m$ are subsets of \mathbb{R} of the form $[\gamma_x^-, \gamma_x^+]$, where $\gamma^\pm : D^m \rightarrow D^m \times \mathbb{R}$ are continuous sections of the form $\gamma^\pm(x) = (x, \gamma_x^\pm)$. If $\gamma_x^- < \gamma_x^+$ for all $x \in D^m$, except possibly when $x \in S^{m-1}$, then X is a closed $(m+1)$ -disk. (Construct a bundle isomorphism to a compact convex set with nonempty interior, which is then necessarily a disk.) A similar observation holds in the PL case. \square

To prove Lemma 4.1.64, it will be convenient to use the correspondence, established later, of 1-mesh bundles and 1-truss bundles; specifically we perform constructions in terms of 1-truss bundles and translate them to 1-mesh bundles by realization.

PROOF OF LEMMA 4.1.64. Let the base stratification (B, g) be cellular. By definition, there is a constructible substratification inclusion $(\underline{B}, g) \hookrightarrow X$ into some regular cell complex X . By removing cells in $X \setminus \underline{B}$, we may assume B is dense in X . Write $Y = \mathbb{I}(B, g)$ for the fundamental poset of the stratification, and (abusing notation) $X = \mathbb{I}X$ for the fundamental poset of the cell complex. Note that the stratified realization of the poset X recovers the original regular cell complex X ; in particular that cell complex is the realization of a simplicial complex.

We now claim that we can choose the cell complex X such that for any $x \in X \setminus Y$ there exists a unique $y \in Y$ such that $y <^{\text{cov}} x$ is a covering in $Y \cup \{x\}$ (see Notation B.1.34). Indeed, pick a cell $x \in X \setminus Y$ of highest dimension that fails the desired uniqueness, i.e. is covered by distinct $y, y' \in Y$; observe that $\dim(y) = \dim(y') = \dim(x) + 1$. Then ‘blow-up’ X at x , replacing x by the simplices in the boundary of its simplicial star in NX , and thereby constructing a new regular cell complex X' (that still contains B as a constructible substratification). This process does not create any new cells that fail the unique covering condition and are of dimension $\dim(x)$, and it does remove the cell x as such a failing cell; the claim follows by induction. (The blow-up process could instead be described using cellular stars, see Terminology B.3.28.)

Consider a 1-mesh bundle $p : (M, f) \rightarrow (B, g)$, and take fundamental posets to form its fundamental 1-truss bundle $q : T \rightarrow Y$ (as described

later in Construction 4.2.11). Pick a complex X satisfying the above unique covering condition. We can extend q to a 1-truss bundle $\tilde{q} : \tilde{T} \rightarrow X$ as follows. Define the fiber of \tilde{q} over the unique arrow $y <^{\text{cov}} x$ to be the identity $\text{id}_{q^{-1}(y)}$; one checks this uniquely extends to a well-defined 1-truss bundle \tilde{q} . Take the mesh realization (as described later in Section 4.2.5.4), to form a 1-mesh bundle $\tilde{p} : (\tilde{M}, \tilde{f}) \rightarrow X$ such that $\tilde{p}|_B \cong p$. Furthermore forming the fiberwise compactification of the 1-mesh bundle \tilde{p} constructs a closed 1-mesh bundle over X whose total stratification is a regular cell complex (by Observation 4.1.65). Since that compactified bundle contains p as a constructible substratification, the total stratification of p is cellular as required. \square

PROOF OF PROPOSITION 4.1.63. Suppose the base stratification (B, g) is cellullable; refine it by a cellular stratification $G : (B, c) \rightarrow (B, g)$. The pullback bundle $G^*p : (M, d) \rightarrow (B, c)$ has cellular total stratification (M, d) by Lemma 4.1.64. The coarsening $\text{Tot}G : (M, d) \rightarrow (M, f)$ exhibits (M, f) as cellullable, as required. \square

Though our standard regularity condition will be cellulability, we mention that various other regularity properties lift from the base to the total stratification of 1-mesh bundles, as follows.

OBSERVATION 4.1.66 (Finiteness and local finiteness lifts). Though we have assumed our stratifications are finite by convention, note that the definition of 1-mesh bundles generalizes to the setting of infinite stratifications. In that broader context, consider a 1-mesh bundle $p : (M, f) \rightarrow (B, g)$ in which the base stratification is finite or locally finite. It follows (because the fibers in 1-mesh bundles are finite stratifications) that the total stratification is, respectively, finite or locally finite as well. —

OBSERVATION 4.1.67 (Frontier-constructibility lifts). Consider a 1-mesh bundle $p : (M, f) \rightarrow (B, g)$, and suppose the base (B, g) is frontier-constructible. It follows that the total stratification (M, f) is again frontier-constructible. —

OBSERVATION 4.1.68 (Pairwise locally path-connectedness lifts). Consider a 1-mesh bundle $p : (M, f) \rightarrow (B, g)$, and suppose the base (B, g) is pairwise locally path-connected. Then the total stratification (M, f) is also pairwise locally path-connected. —

Together, the preceding two observations imply that reasonable regularity lifts from the base to the total stratifications of 1-mesh bundles.

4.1.3. n -Meshes and their bundles.

SYNOPSIS. We define n -meshes as towers of 1-mesh bundles, and describe their realizations in the standard euclidean n -proframe. We then introduce, more generally, n -mesh bundles as towers over a stratified base space. Next we discuss maps of n -meshes and n -mesh bundles, and delineate notions of

singular, regular, balanced, submesh, degeneracy, and coarsening such maps. Finally, we mention various categories and ∞ -categories of n -meshes and their bundles.

4.1.3.1. The definition of n -meshes. As n -trusses were towers of 1-truss bundles, so n -meshes will be towers of 1-mesh bundles, as follows.

DEFINITION 4.1.69 (n -Meshes). An n -**mesh** M is a sequence of 1-mesh bundles

$$(M_n, f_n) \xrightarrow{p_n} (M_{n-1}, f_{n-1}) \xrightarrow{p_{n-1}} \cdots \xrightarrow{p_2} (M_1, f_1) \xrightarrow{p_1} (M_0, f_0) = *$$

in which the base stratification of each bundle p_i is the total stratification of the subsequent bundle p_{i-1} .

A 1-mesh comes equipped with a 1-framed realization, embedding the mesh in \mathbb{R} ; as a byproduct of the 1-framed realizations of its constituent 1-mesh bundles, an n -mesh will have an ‘ n -framed realization’, embedding the mesh in \mathbb{R}^n , as follows. Recall from Terminology 3.2.8 that the standard euclidean n -proframe $\mathcal{P}_{\mathbb{R}}^n = (\pi_n, \pi_{n-1}, \dots, \pi_1)$ is the tower of projections $\pi_i : \mathbb{R}^i = \mathbb{R}^{i-1} \times \mathbb{R} \rightarrow \mathbb{R}^{i-1}$, forgetting the last coordinate.

CONSTRUCTION 4.1.70 (n -Framed realizations of n -meshes). Consider an n -mesh M , consisting of the 1-mesh bundles $p_i : (M_i, f_i) \rightarrow (M_{i-1}, f_{i-1})$ with 1-framed realizations $M_i \hookrightarrow M_{i-1} \times \mathbb{R}$. Define a map $\gamma = (\gamma_n, \gamma_{n-1}, \dots, \gamma_0)$ of towers of spaces

$$\begin{array}{ccccccc} M_n & \xrightarrow{p_n} & M_{n-1} & \xrightarrow{p_{n-1}} & \cdots & \xrightarrow{p_2} & M_1 & \xrightarrow{p_1} & M_0 = * \\ \gamma_n \downarrow & & \gamma_{n-1} \downarrow & & \cdots & & \downarrow \gamma_1 & & \downarrow \gamma_0 \\ \mathbb{R}^n & \xrightarrow{\pi_n} & \mathbb{R}^{n-1} & \xrightarrow{\pi_{n-1}} & \cdots & \xrightarrow{\pi_2} & \mathbb{R}^1 & \xrightarrow{\pi_1} & \mathbb{R}^0 \end{array}$$

by inductively setting γ_i to be the composite of the realization $M_i \hookrightarrow M_{i-1} \times \mathbb{R}$ with the product $\gamma_{i-1} \times \mathbb{R} : M_{i-1} \times \mathbb{R} \hookrightarrow \mathbb{R}^{i-1} \times \mathbb{R}$.

We refer to the embedding (of towers of spaces) $\gamma : M \hookrightarrow \mathcal{P}_{\mathbb{R}}^n$ as the ‘ n -framed realization’, or simply ‘ n -realization’, of the n -mesh M . Note that the n -realization γ is determined by its top component $\gamma_n : M_n \hookrightarrow \mathbb{R}^n$ and, abusing terminology, we may refer to that top embedding itself as the n -realization. —

TERMINOLOGY 4.1.71 (Support of n -realized meshes). Given an n -mesh M with n -realization γ , we refer to $\gamma_n(M_n) \subset \mathbb{R}^n$ as the ‘support’ of the (n -realized) mesh. —

Given an n -mesh M with n -realization γ , note that the components γ_i of γ may either be considered as subspace embeddings $\gamma_i : M_i \hookrightarrow \mathbb{R}^i$ or as stratified maps $\gamma_i : (M_i, f_i) \rightarrow \mathbb{R}^i$; as stratified maps they are coarsenings onto their images.

TERMINOLOGY 4.1.72 (Closed and open n -meshes). An n -mesh is called ‘closed’ or ‘open’ if each of the constituent 1-mesh bundles in its tower is

closed or open, respectively, and is called ‘mixed’ if it is neither closed nor open. —

EXAMPLE 4.1.73 (2-Meshes). In Figure 4.14, we depict two 2-meshes via their 2-framed realizations in the standard proframe $\mathbb{R}^2 \rightarrow \mathbb{R}^1 \rightarrow \mathbb{R}^0$. The first 2-mesh (on the left) has half-open half-closed fibers in both the mesh bundles p_1 and p_2 , and so is mixed. Note that the 2-truss, obtained as the tower of fundamental posets of this 2-mesh, was illustrated in Figure 2.42.

The second 2-mesh (on the right) has open fibers in both its bundles, and thus is an open 2-mesh. The fundamental 2-truss of this 2-mesh is illustrated later on the lower right of Figure 5.31. —

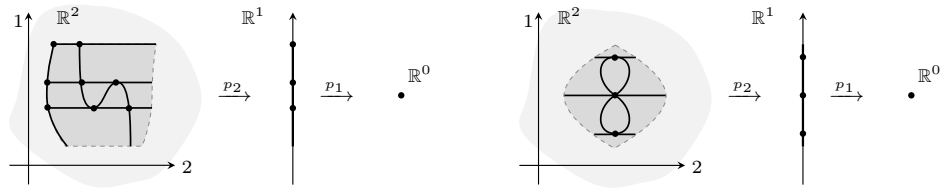

FIGURE 4.14. 2-Meshes and their framed realizations.

EXAMPLE 4.1.74 (3-Meshes). Earlier in Figure 4.1, we depicted a 3-mesh via its realization in the standard proframe $\mathbb{R}^3 \rightarrow \mathbb{R}^2 \rightarrow \mathbb{R}^1$ (we usually omit the last projection $\mathbb{R}^1 \rightarrow \mathbb{R}^0$). In this mesh, the bundle p_1 is open, while the bundles p_2 and p_3 are both closed. The 3-truss arising as the fundamental poset tower of this 3-mesh is illustrated later in Figure 5.32. (That figure also indicates a subposet of the total poset of the 3-truss tracing out a combinatorial Dehn-twist, and depicts the corresponding geometric Dehn-twist stratification of the cylinder; the 3-mesh depicted here is in fact the coarsest mesh refining that geometric stratification, as illustrated on the left in Figure 5.20.)

In Figure 4.15, we depict another 3-mesh, again via its realization. Here, all three 1-mesh bundles p_1 , p_2 , and p_3 are open. The 3-truss given by the fundamental poset tower of this 3-mesh was illustrated at the beginning of this Chapter 4 and is illustrated again later in Figure 5.22. (That latter figure also indicates a subposet of the total poset delineating a combinatorial cusp configuration, and depicts, roughly speaking, a corresponding geometric cusp stratification; the 3-mesh depicted here is in fact the coarsest mesh refining a version of that geometric stratification. That refinement is illustrated, though in a partially compactified form, on the right in Figure 5.20. Notice that the top slice of that partially compactified 3-mesh is, up to frame reflection, the first 2-mesh from Figure 4.14.) —

OBSERVATION 4.1.75 (n -Meshes are cellular). By Lemma 4.1.64, cellularity lifts along 1-mesh bundles; that property implies that for n -meshes

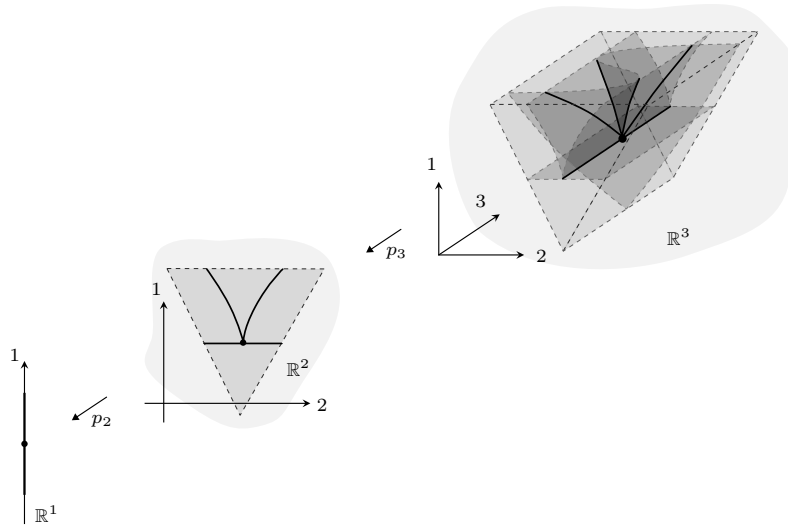

FIGURE 4.15. An open 3-mesh.

M , each stratification (M_i, f_i) is cellular, and thus also conical (see [Observation B.3.26](#)). —

4.1.3.2. n -Mesh bundles. Of course we may consider suitably parametrized families of n -meshes, and those are most simply and conveniently encoded as towers of 1-mesh bundles over a nontrivial base stratification, as follows.

DEFINITION 4.1.76 (n -Mesh bundles). An n -mesh bundle over a stratification (B, g) is a sequence of 1-mesh bundles

$$(M_n, f_n) \xrightarrow{p_n} (M_{n-1}, f_{n-1}) \xrightarrow{p_{n-1}} \cdots \xrightarrow{p_2} (M_1, f_1) \xrightarrow{p_1} (M_0, f_0) = (B, g)$$

in which the base stratification of each bundle is the total stratification of the next bundle.

We call a bundle ‘closed’ or ‘open’ if all its constituent 1-mesh bundles are, respectively.

CONSTRUCTION 4.1.77 (n -Framed realizations of bundles). Consider an n -mesh bundle $p = (p_n, p_{n-1}, \dots, p_1)$ over a base stratification (B, g) . Replacing, in [Construction 4.1.70](#), the standard projections π_i by the products $B \times \pi_i$, define a map of towers

$$\begin{array}{ccccccc} M_n & \xrightarrow{p_n} & M_{n-1} & \xrightarrow{p_{n-1}} & \cdots & \xrightarrow{p_2} & M_1 & \xrightarrow{p_1} & M_0 = B \\ \gamma_n \downarrow & & \gamma_{n-1} \downarrow & & \cdots & & \downarrow \gamma_1 & & \downarrow \text{id}_B \\ B \times \mathbb{R}^n & \xrightarrow{B \times \pi_n} & B \times \mathbb{R}^{n-1} & \xrightarrow{B \times \pi_{n-1}} & \cdots & \xrightarrow{B \times \pi_2} & B \times \mathbb{R}^1 & \xrightarrow{B \times \pi_1} & B \times \mathbb{R}^0 \end{array}$$

We refer to the map $\gamma = (\gamma_n, \gamma_{n-1}, \dots, \gamma_0)$ as the ‘ n -framed realization’ or ‘ n -realization’ of the bundle; as before we also refer similarly just to the top map $\gamma_n : M_n \hookrightarrow B \times \mathbb{R}^n$. —

TERMINOLOGY 4.1.78 (Support of n -realized mesh bundles). The ‘support’ of a mesh bundle M is the image $\gamma_n(M_n) \subset B \times \mathbb{R}^n$ of its n -realization. —

Recall from Remark 4.1.16 that there is a contractible space of suitable 1-realizations of a 1-mesh; the same applies to 1-mesh bundles. The situation for n -meshes and n -mesh bundles is similar, as follows.

REMARK 4.1.79 (Contractible choice of equivalent n -realizations). As discussed in Remark 4.1.16, we could have defined 1-meshes to come equipped with a framed-homeomorphism class of 1-realizations, rather than a specific 1-realization, and such a class is contractible. By applying that shift in perspective to every fiber of all the 1-mesh bundles in the tower of an n -mesh bundle, Construction 4.1.77 produces, for any n -mesh, a contractible space of n -framed realizations, all of which are framed homeomorphic on every fiber. In fact, that contractible space is exactly the space of maps (of towers into the standard proframe) that are obtained from any given n -framed realization by post-composing with an n -framed homeomorphism of euclidean space; that notion of n -framed homeomorphism is made precise shortly in Definition 4.1.86. We thus may and will implicitly conceive of n -mesh realizations up to n -framed homeomorphism when convenient. —

TERMINOLOGY 4.1.80 (Truncations). Given an n -mesh bundle $p = (p_n, p_{n-1}, \dots, p_1)$ over the base stratification (B, g) , its (lower) ‘ k -truncation’ $p_{\leq k}$ is the k -mesh bundle $(p_k, p_{k-1}, \dots, p_1)$ over the same base, obtained by preserving only the k lowest 1-mesh bundles of the tower. —

Recall from Definition 4.1.41 the notion of categorical 1-mesh bundle, in which the entrance path structure of the total stratification is allowed to depend on the base entrance path (and thus on the fundamental category, not just fundamental poset, of the base). The corresponding notion in the context of n -meshes is as follows.

DEFINITION 4.1.81 (Categorical n -mesh bundles). A **categorical n -mesh bundle** p over a stratification (B, g) is a sequence of categorical 1-mesh bundles $(M_n, f_n) \xrightarrow{p_n} (M_{n-1}, f_{n-1}) \xrightarrow{p_{n-1}} \dots \xrightarrow{p_2} (M_1, f_1) \xrightarrow{p_1} (M_0, f_0) = (B, g)$. —

REMARK 4.1.82 (Posetal refinements of categorical bundles). Every categorical n -mesh bundle over a posetal base stratification (B, g) is necessarily a posetal n -mesh bundle (see also Proposition 4.1.43). From this it follows that any categorical n -mesh bundle over a cellable base stratification can be refined by a posetal mesh bundle: indeed, cellular stratifications are posetal (see Observation B.3.31), and the required refinement can be obtained by a pullback (see Construction 4.1.93). —

REMARK 4.1.83 (Unified classification of posetal and categorical bundles). We will see later that (posetal) n -mesh bundles over (sufficiently nice) base

stratifications (B, g) are classified by functors $\mathbb{I}g \rightarrow \mathbf{TBord}^n$ from the fundamental poset of the base to the classifying category of n -trusses and their bordisms. In the case of categorical mesh bundles the same classifying category applies (see also Remark 4.1.44), in that categorical n -mesh bundles are classified by ∞ -functors $\mathbb{I}_\infty(g) \rightarrow \mathbf{TBord}^n$, or equivalently by 1-categorical functors $\mathbb{I}_1(g) \rightarrow \mathbf{TBord}^n$. \square

4.1.3.3. Maps of n -meshes and their bundles. The notion of map of 1-mesh bundles from Definition 4.1.51 straightforwardly provides a notion of map of n -meshes and n -mesh bundles, as follows.

DEFINITION 4.1.84 (Maps of n -mesh bundles). Consider an n -mesh bundle $p = (p_n, p_{n-1}, \dots, p_1)$ over (B, g) and an n -mesh bundle $q = (q_n, q_{n-1}, \dots, q_1)$ over (C, h) . A **map of n -mesh bundles** $F : p \rightarrow q$ is a map of towers

$$\begin{array}{ccccccc} (M_n, f_n) & \xrightarrow{p_n} & (M_{n-1}, f_{n-1}) & \xrightarrow{p_{n-1}} & \cdots & \xrightarrow{p_2} & (M_1, f_1) & \xrightarrow{p_1} & (M_0, f_0) = (B, g) \\ \downarrow F_n & & \downarrow F_{n-1} & & \cdots & & \downarrow F_1 & & \downarrow F_0 \\ (N_n, g_n) & \xrightarrow{q_n} & (N_{n-1}, g_{n-1}) & \xrightarrow{q_{n-1}} & \cdots & \xrightarrow{q_2} & (N_1, g_1) & \xrightarrow{q_1} & (N_0, g_0) = (C, h) \end{array}$$

where F_0 is a stratified map, and each F_i (for $i > 0$) is a 1-mesh bundle map $p_i \rightarrow q_i$. When the base stratifications are trivial, i.e. $(B, g) = (C, h) = *$, this definition provides a notion of **map of n -meshes**. \square

EXAMPLE 4.1.85 (A 3-mesh map). In Figure 4.16, we depict a map of open 3-meshes, which is a substratification on each stage. The source 3-mesh was depicted earlier in Figure 2.41 along with its fundamental 3-truss. (That 3-truss is shown again later in Figure 5.33, with an indication of a subset of the total poset tracing out a combinatorial braid. That same figure depicts, roughly speaking, a corresponding geometric braid stratification; the 3-mesh depicted here is in fact the coarsest mesh refining a version of that geometric stratification.)

Note that the target 3-mesh has as its 2-mesh truncation the one previously shown on the right in Figure 4.14. Though we do not anywhere illustrate the fundamental 3-truss of the target 3-mesh, the dual of that fundamental 3-truss appeared in Figure 3.2. \square

In the previous example, we implicitly illustrated a mesh map, via its realization, in terms of the effect on the mesh supports in the standard proframed euclidean space. The maps of subspaces of euclidean spaces that arise in this way are extremely constrained by respecting the proframe structure, and we describe them precisely as follows.

DEFINITION 4.1.86 (Framed maps of euclidean subspaces). For euclidean subspaces $Z \subset \mathbb{R}^n$ and $W \subset \mathbb{R}^n$, an **n -framed map** is a map $F : Z \rightarrow W$ that, for every $0 \leq i < n$, descends along the standard projection $\pi_{>i} = \pi_{i+1} \circ \cdots \circ \pi_n : \mathbb{R}^n \rightarrow \mathbb{R}^i$, to a map $F_i : \pi_{>i}(Z) \rightarrow \pi_{>i}(W)$; i.e. the map F_i satisfies

$$F_i \circ \pi_{>i} = \pi_{>i} \circ F.$$

\diamond It would be good to have an example of a map that's not an embedding

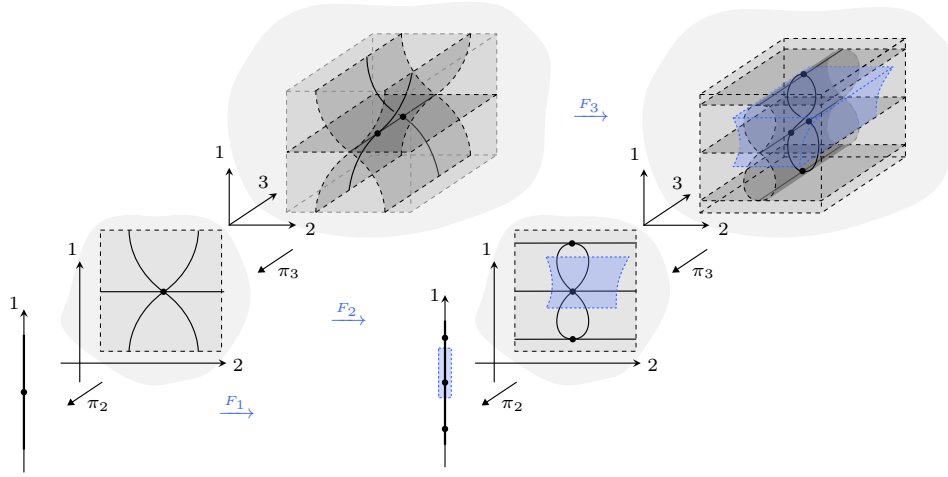

FIGURE 4.16. A 3-mesh map.

Similarly, given subspaces $Z \subset B \times \mathbb{R}^n$ and $W \subset C \times \mathbb{R}^n$ and a map $G : B \rightarrow C$, an n -framed map over the base map G is a map $F : Z \rightarrow W$ that, for every $0 \leq i < n$, descends to a map $F_i : (\text{id}_B \times \pi_{>i})(Z) \rightarrow (\text{id}_C \times \pi_{>i})(W)$, with $F_0 = G$; i.e. the map F_i satisfies

$$F_i \circ (\text{id}_B \times \pi_{>i}) = (\text{id}_C \times \pi_{>i}) \circ F. \quad \text{—}$$

Note that the notion of an n -framed map $F : Z \rightarrow W$ may equivalently be specified by asking for there to exist a tower of maps $F_i : \pi_{>i}(Z) \rightarrow \pi_{>i}(W)$, with $F = F_n$, such that $F_{i-1} \circ \pi_i = \pi_i \circ F_i$.

TERMINOLOGY 4.1.87 (Framed maps for n -realized spaces and bundles). Given surjective maps $p : M \rightarrow B$ and $q : N \rightarrow C$ equipped with base-preserving ‘ n -realizations’ $\gamma_p : M \hookrightarrow B \times \mathbb{R}^n$ and $\gamma_q : N \hookrightarrow C \times \mathbb{R}^n$, a ‘framed bundle map’ $F : M \rightarrow N$ is a bundle map (i.e. $q \circ F = G \circ p$ for some $G : B \rightarrow C$) that induces an n -framed map $F : \gamma_p(M) \rightarrow \gamma_q(N)$ over the base map G . When B and C are trivial, we simply speak of a ‘framed map’ $F : M \rightarrow N$. —

OBSERVATION 4.1.88 (Framed maps and mesh bundle maps). Consider n -mesh bundles $p = ((M_n, f_n) \rightarrow \cdots \rightarrow (M_0, f_0) = (B, d))$ and $q = ((N_n, g_n) \rightarrow \cdots \rightarrow (N_0, g_0) = (C, e))$ with respective realizations $\gamma_M : M_n \hookrightarrow \mathbb{R}^n$ and $\gamma_N : N_n \hookrightarrow \mathbb{R}^n$.

- (1) Any stratified map $F : \gamma_p(M_n, f_n) \rightarrow \gamma_q(N_n, g_n)$ that is framed over a base map F_0 in the sense of Definition 4.1.86 determines a mesh bundle map $\tilde{F} : p \rightarrow q$ (such that $\gamma_q \circ \tilde{F}_n = F \circ \gamma_p$ and $\tilde{F}_0 = F_0$).
- (2) Conversely, given a mesh bundle map $F : p \rightarrow q$ the top component F_n is a framed bundle map in the sense of Terminology 4.1.87 on underlying spaces. Thus, F determines a framed stratified map $\tilde{F} : \gamma_p(M_n, f_n) \rightarrow \gamma_q(N_n, g_n)$ (such that $\gamma_q \circ F_n = \tilde{F} \circ \gamma_p$). —

We record the following obvious extensions of 1-mesh bundle terminology to the case of n -mesh bundle maps.

TERMINOLOGY 4.1.89 (Singular, regular, and balanced maps of n -mesh bundles). We call an n -mesh bundle map F ‘singular’ or ‘regular’ or ‘balanced’ if all of its constituent 1-mesh bundle maps F_i (for $1 \leq i \leq n$) are respectively singular or regular or balanced, in the sense of **Terminology 4.1.52**, i.e. if every bundle map F_i satisfies the respective condition on every fiber. —

TERMINOLOGY 4.1.90 (Subbundles and submeshes). We call an n -mesh bundle map F a ‘subbundle’ if the map F_0 is a substratification and all the maps F_i (for $i > 0$) are fiberwise submesh inclusions of 1-meshes in the sense of **Terminology 4.1.19**. A subbundle map between n -meshes is called simply a ‘submesh’. —

TERMINOLOGY 4.1.91 (Degeneracies and coarsenings of n -meshes and n -mesh bundles). An n -mesh bundle map F is called a ‘degeneracy’ or a ‘coarsening’ when all the constituent 1-mesh bundle maps F_i (for $i > 0$) are, on every fiber, degeneracies or coarsenings of 1-meshes as defined in **Terminology 4.1.20**, and the stratified base map F_0 is of a corresponding designation (i.e. a quotient map or a homeomorphism on underlying spaces).³⁰ —

Note that any n -mesh coarsening induces a tower of homeomorphisms of underlying spaces, and thus provides a tower of coarsenings of stratifications in the usual sense (see **Definition B.2.4**).

TERMINOLOGY 4.1.92 (Base preserving maps). We call an n -mesh bundle map F ‘over the base’ (B, g) or ‘base preserving’ when the 0-stage map F_0 is an identity id_B . —

We next generalize pullbacks of 1-mesh bundles (see **Construction 4.1.57**) to n -mesh bundles. Note that we may pullback not only along a map of base stratifications, but along a truncated mesh bundle map, as follows.

CONSTRUCTION 4.1.93 (Pullbacks of mesh bundles). Consider an n -mesh bundle $p = ((M_n, f_n) \xrightarrow{p_n} \dots \xrightarrow{p_1} (M_0, f_0))$, and a stratification (N_0, g_0) or an i -mesh bundle $q = ((N_i, g_i) \xrightarrow{q_i} \dots \xrightarrow{q_1} (N_0, g_0))$ for some fixed $0 < i < n$. Given an i -mesh bundle map $G : q \rightarrow p_{\leq i}$ from the bundle q to the truncation $p_{\leq i}$, apply inductively the pullback of 1-mesh bundles, from **Construction 4.1.57**, to obtain the tower of maps

$$\begin{array}{ccccccc} (G^* M_n, G^* f_n) & \xrightarrow{G^* p_n} & \dots & \xrightarrow{G^* p_{i+2}} & (G^* M_{i+1}, G^* f_{i+1}) & \xrightarrow{G^* p_{i+1}} & (N_i, g_i) \xrightarrow{q_i} \dots \xrightarrow{q_1} (N_0, g_0) \\ \text{Tot}^{n-i} G \downarrow & \lrcorner & & \lrcorner & \text{Tot}^1 G \downarrow & \lrcorner & \downarrow G_i & & \downarrow G_0 \\ (M_n, f_n) & \xrightarrow{p_n} & \dots & \xrightarrow{p_{i+2}} & (M_{i+1}, f_{i+1}) & \xrightarrow{p_{i+1}} & (M_i, f_i) \xrightarrow{p_i} \dots \xrightarrow{p_1} (M_0, f_0) \end{array}$$

³⁰Analogously to the truss case discussed in **Terminology 2.3.67**, we refer to a ‘coarsening of meshes’ as a ‘refinement of meshes’, albeit with a grammatical contravariance.

The above remark could probably be clearer. Option: both ways. Recharacterize mesh maps in terms of framed maps. In given mesh map, get a framed map that respects the stratification; given framed map that’s stratified, descends to a mesh map. [Following that option, statements are now very clear]

Here, for $1 \leq j \leq n - i$, the maps G^*p_{i+j} and $\text{Tot}^j G$ are defined by the pullback of p_{i+j} along $\text{Tot}^{j-1} G$ (with $\text{Tot}^0 G = G_i$). We call the top tower the ‘pullback n -mesh bundle’ G^*p , and we call the vertical map of towers the ‘pullback n -mesh bundle map’ $\text{Tot} G : G^*p \rightarrow p$. \square

TERMINOLOGY 4.1.94 (Bundle restrictions). In the special case of the previous construction where $i = 0$, i.e. the pullback is along simply a stratified map, and when $G_0 : (C, h) \equiv (N_0, g_0) \hookrightarrow (M_0, f_0) \equiv (B, g)$ is a substratification, we call the pullback $G^*p \rightarrow p$ the ‘restriction of the n -mesh’ along the base map $C \hookrightarrow B$, and we denote the restriction by $p|_C \hookrightarrow p$. Note that restricting an n -mesh bundle to a point in its base provides a notion of the ‘fiber n -mesh’ at that point. \square

4.1.3.4. Categories of n -meshes and their bundles. Equipped with the notions of n -meshes, n -mesh bundles, and their maps, we can now introduce various categories of meshes and mesh bundles.

NOTATION 4.1.95 (Categories of n -meshes and n -mesh bundles). Using the previously defined notions of maps, we have the following categories:

Mesh_n n -Meshes and their maps.

MeshBun_n n -Mesh bundles and their maps.

$\text{Mesh}_n(B, g)$ n -Mesh bundles over (B, g) and their base-preserving maps.

In each case, the decoration \dot{M} or \bar{M} will indicate the restriction to the open objects and regular maps, or closed objects and singular maps, respectively. \square

The set of mesh maps, between any two meshes, has a natural topology, and hence the category of meshes (or mesh bundles) is topologically enriched [Kel82], as follows.

CONVENTION 4.1.96 (∞ -Categories modeled by Top -enriched categories). Unless otherwise indicated, we will use the term ‘ ∞ -category’ to refer to a Top -enriched category (see [Lur09, §1]). In certain circumstances, for instance involving posets with the specialization topology, we also use $k\text{Top}$ -enriched categories (see Notation B.1.2) as a model of ∞ -categories, but in those cases will refer to the enrichment specifically. We use the term ‘quasicategory’ to refer to a simplicial set with inner horn fillers (see [Joy02]).

The primary contravention of that convention is that we use the term ‘fundamental ∞ -category’ to refer to a quasicategory. Note also that for suitable emphasis we let ‘ ∞ -functor’ refer either to a Top -enriched functor in the context of ∞ -categories, to a $k\text{Top}$ -enriched functor in the context of $k\text{Top}$ -enriched categories, or to a simplicial map in the context of quasicategories. Of course, we may and sometimes will consider ordinary 1-categories as ∞ -categories, by giving their hom-sets the discrete topology, or as quasicategories, by taking their simplicial nerve. \square

NOTATION 4.1.97 (∞ -Categories of n -mesh bundles). By topologizing the hom-sets $\text{Mesh}_n(M, N)$ as subspaces of the hom-spaces $\text{Map}(M_n, N_n) \in \text{Top}$

(and similarly for mesh bundles and mesh bundles with a fixed base), we obtain the following ∞ -categories:

- Mesh_n n -Meshes and their spaces of maps.
- $\mathit{MeshBun}_n$ n -Mesh bundles and their spaces of maps.
- $\mathit{Mesh}_n(B, g)$ n -Mesh bundles over (B, g) and their spaces of base-preserving maps.

As before, in each case, the decoration $\overset{\circ}{M}$ or \bar{M} will indicate the restriction to the (**Top**-enriched) subcategory of open objects and regular maps, or closed objects and singular maps, respectively. We further write $\mathit{Mesh}_n^{\text{bal}}(B, g)$ for the wide subcategory of $\mathit{Mesh}_n(B, g)$ comprising only balanced mesh maps. —

REMARK 4.1.98 (Truncating is continuous). Truncating from an n -mesh to a k -mesh provides a **Top**-enriched functor $(-)_{\leq k} : \mathit{Mesh}_n(B, g) \rightarrow \mathit{Mesh}_k(B, g)$ of the ∞ -categories of mesh bundles over the base (B, g) . —

NOTATION 4.1.99 (∞ -Categories with degeneracies and coarsenings). By restricting the morphisms to be degeneracies or coarsenings, we obtain two wide sub-**Top**-categories of Mesh_n , namely the ∞ -category $\mathit{Mesh}_n^{\text{deg}}$ of n -meshes and degeneracies and the ∞ -category $\mathit{Mesh}_n^{\text{crs}}$ of n -meshes and coarsenings. —

Recall from Remark 2.2.75 that there is a quasicategory \mathcal{TBord}^1 of ‘1-trusses and their bordisms’, which has 0-simplices being the 1-trusses, 1-simplices being the 1-truss bordisms, and more generally k -simplices being 1-truss bundles over the combinatorial k -simplex. There is an analogous quasicategory \mathcal{MBord}_1 of ‘1-meshes and their bordisms’, which has 0-simplices being the 1-meshes, 1-simplices being the 1-mesh bundles over the standard stratified 1-simplex, and k -simplices being 1-mesh bundles over the standard stratified k -simplex. The same scheme provides the following quasicategory in the n -mesh case.

DEFINITION 4.1.100 (Quasicategories of n -meshes and their bordisms). The **quasicategory of n -meshes and their bordisms** \mathcal{MBord}_n has k -simplices being the n -mesh bundles over the stratified k -simplex $\|[k]\|$; simplicial maps $f : [k] \rightarrow [l]$ operate by bundle pullback along the stratified maps $\|f\| : \|[k]\| \rightarrow \|[l]\|$. —

Echoing the truss terminology, we sometimes refer to the 1-simplices of \mathcal{MBord}_n , i.e. the n -mesh bundles over the stratified 1-simplex, as ‘ n -mesh bordisms’. However, once we establish an equivalence between the quasicategory \mathcal{MBord}_n and the 1-category \mathbf{TBord}^n , we will for the most part work with the latter truss category, and so mesh bordisms will not play a substantial direct role henceforth.

REMARK 4.1.101 (Categorical mesh bordisms). Recall from Proposition 4.1.43 that categorical bundles over posets are posetal. As a consequence, if we replaced posetal mesh bundles by categorical mesh bundles in Definition 4.1.100, the resulting ‘quasicategory of categorical n -meshes and their

bordisms' would be identical to the quasicategory of n -meshes and their bordisms. This coincidence is also encoded in the fact that posetal and categorical mesh bundles will have the same classifying category. \square

4.2. Weak equivalence of meshes and trusses

From the outset, the notion of 1-trusses was designed to model the fundamental posets of certain stratifications of intervals, namely 1-meshes, and the notion of 1-truss bundles was formulated to model the fundamental posets of suitable constructible bundles of stratified intervals, namely 1-mesh bundles; thus the whole theory of n -trusses is motivated, in retrospect, from the structures arising in the fundamental posets of n -meshes. It will come as no surprise, then, that the fundamental poset induces a *fundamental truss functor* \mathbb{T} from meshes to trusses. An example of a mesh and its associated fundamental truss is illustrated in Figure 4.17. The total stratification of the 3-mesh is depicted on the left, and the total poset of the associated 3-truss is depicted on the right; the lower stages of the mesh and the truss are obtained by successively (from highest to lowest) projecting out the realization or frame vectors, respectively.

What is less immediate than the existence of a fundamental truss associated to a mesh, is that the fundamental truss is a faithful combinatorial encoding of the topological mesh. The encoding is faithful in the sense that meshes with isomorphic fundamental trusses are themselves isomorphic, and moreover mesh maps inducing the same fundamental truss map are themselves homotopic. Furthermore, every truss arises as the fundamental truss of some mesh. Indeed, at least for closed trusses, the stratified realization of the truss posets induces a *mesh realization functor* $\|\cdot\|_{\mathbb{M}}$ from trusses to meshes. (And the fundamental truss of the mesh realization of a truss is isomorphic to the original truss.) Read now from right to left, Figure 4.17 also provides an example of a truss and (up to homotopic artistic license) its associated mesh realization. Notice that the two horizontal 2-disc strata of the 3-mesh are visible in the 3-truss as the 2-truss fibers over the two singular points of the projected 1-truss; similarly the central skew 2-disc stratum of the 3-mesh is visible in the 3-truss as the downward closure of the 1-truss fiber over the central singular point of the projected 2-truss.

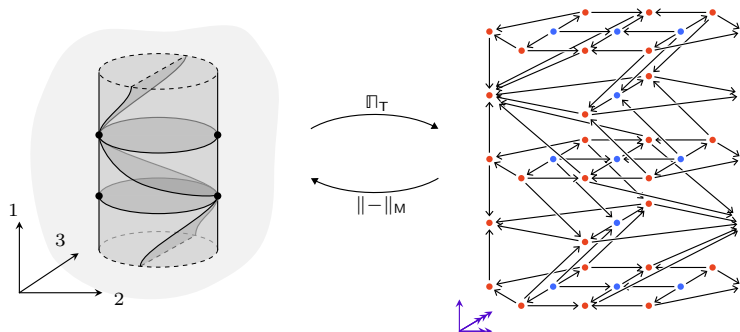

FIGURE 4.17. A corresponding 3-mesh and 3-truss.

OUTLINE. In Section 4.2.1, we overview the equivalences between meshes and trusses, emphasizing the cases of closed meshes and trusses, of open meshes and trusses, and of mesh and truss bordisms. In Section 4.2.2, we construct the fundamental truss functor from meshes to trusses, first as an ordinary functor and then as an ∞ -functor. Then in Section 4.2.3, we prove the fundamental truss functor is essentially injective, in the sense that meshes with isomorphic fundamental trusses are isomorphic. Furthermore in Section 4.2.4, we prove the fundamental truss ∞ -functor is weakly faithful, in that the hom fibers of that functor are either empty or contractible. Next in Section 4.2.5, we construct the mesh realization functor from trusses to meshes, as a right inverse to the fundamental truss functor. Finally in Section 4.2.6, we assemble the proof of the equivalences of meshes and trusses, and present two applications, namely to the classification of framed subdivisions of framed cells and to the dualization equivalence of open and closed meshes.

4.2.1. Overview of the equivalences. We state and sketch the context and relationships among several incarnations of equivalences between meshes and trusses, specifically for closed meshes and trusses, open meshes and trusses, closed or open mesh bundles and truss bundles, suitably enriched categories of general mesh bundles and truss bundles, and quasicategories of mesh bordisms and truss bordisms. We then preview two applications of these equivalences, namely to a classification of framed subdivisions of framed regular cells by truss subdivisions of truss blocks, and to a dualization equivalence between closed and open meshes.

The equivalences between meshes and trusses will be witnessed by a *fundamental truss functor* \mathbb{T} and conversely by a *mesh realization functor* $\|- \|_{\mathbb{M}}$. As the names suggest, the former is a variation of the fundamental poset functor, and the latter is a variation of the stratified realization functor.³¹

The *fundamental truss functor* will take an n -mesh M , given by a tower of 1-mesh bundles, to an n -truss $\mathbb{T}M$, given by a tower of 1-truss bundles, defined by applying the fundamental poset functor to the mesh tower. The *mesh realization functor* will take an n -truss T , given by a tower of 1-truss bundles, to an n -mesh $\|T\|_{\mathbb{M}}$, given by a tower of 1-mesh bundles, defined (roughly speaking) by applying the stratified realization functor to the truss tower. For both the fundamental truss and mesh realization functors, the 1-mesh structure of every fiber in the mesh tower induces or is induced by the 1-truss structure of every fiber in the truss tower.

THEOREM 4.2.1 (Weak equivalence of meshes and trusses). *The fundamental truss and mesh realization functors provide weak equivalences*

$$\begin{array}{ccc} \mathring{Mesh}_n & \xrightleftharpoons[\|- \|_{\mathbb{M}}]{\mathbb{T}} & \bar{Trs}_n \\ \mathring{Mesh}_n & \xrightleftharpoons[\|- \|_{\mathbb{M}}]{\mathbb{T}} & \mathring{Trs}_n \end{array}$$

³¹In general the mesh realization will not strictly preserve identities, and so will be just a semifunctor, but we suppress that subtlety in our overview.

between the ∞ -category of closed n -meshes and the 1-category of closed n -trusses, and correspondingly for open meshes and open trusses.

That core theorem, worth demarcating, is simply the specialization to the trivial base of the corresponding statement for mesh and truss bundles, as follows.

THEOREM 4.2.2 (Weak equivalence of mesh and truss bundles). *Given a cellulable stratification (B, g) , the fundamental truss and mesh realization functors provide weak equivalences*

$$\begin{array}{ccc} \bar{\mathcal{M}}esh_n(B, g) & \xrightleftharpoons[\|-\|_{\mathbb{M}}]{\mathbb{P}_{\mathbb{T}}} & \bar{\mathcal{T}}rs_n(\mathbb{P}g) \\ \mathring{\mathcal{M}}esh_n(B, g) & \xrightleftharpoons[\|-\|_{\mathbb{M}}]{\mathbb{P}_{\mathbb{T}}} & \mathring{\mathcal{T}}rs_n(\mathbb{P}g) \end{array}$$

between the ∞ -category of closed n -mesh bundles over the base stratification (B, g) and the 1-category of closed n -truss bundles over the base poset $\mathbb{P}g$, and correspondingly for open mesh bundles and open truss bundles.

These results are established, following the development of the necessary tooling, in [Section 4.2.6](#).

REMARK 4.2.3 (Equivalence of categorical bundles). The preceding result generalizes to an equivalence between the ∞ -category of closed (or open) categorical n -mesh bundles (see [Definition 4.1.81](#)) and the 1-category of closed (or open) categorical n -truss bundles (see [Remark 2.3.53](#)). Thereby, a categorical n -mesh bundle over a stratification (B, g) corresponds to a categorical n -truss bundle over the fundamental category $\mathbb{P}_1(B, g)$. (The proofs given in the posetal case will carry over to the categorical case, keeping in mind that certain key steps presume the base stratification is cellular, therefore 0-truncated, in which case the notions of categorical and posetal mesh bundles coincide, and the fundamental category and fundamental poset are identical.) —

The above theorems restrict attention to closed or open meshes and trusses, and thereby avoid complications arising from non-invertible higher morphisms in the case of mixed meshes and trusses; those complications may be encoded obliquely in an enriched version of the fundamental truss functor, as follows.

REMARK 4.2.4 (Enriched fundamental truss functor). Recall from [Remark 2.3.39](#) that natural transformations between truss bundle maps provide a poset structure on the hom-sets in the category of truss bundles, and passing to the specialization topology yields the $k\mathbf{Top}$ -enriched category $\mathcal{F}rs_n(X)$ of n -truss bundles over the base poset X . The (mixed) fundamental truss functor $\mathbb{P}_{\mathbb{T}}$ will be suitably continuous, giving an ∞ -functor on all meshes:

$$\mathcal{M}esh_n(B, g) \xrightleftharpoons[\|-\|_{\mathbb{M}}]{\mathbb{P}_{\mathbb{T}}} \mathcal{F}rs_n(\mathbb{P}g)$$

This functor will be recorded in Proposition 4.2.16. However, the (mixed) mesh realization functor $\|-\|_{\mathbb{M}} : \mathbf{Tr}_n(\mathbb{I}g) \rightarrow \mathbf{Mesh}_n(B, g)$ (which will be given in Notation 4.2.60 and Construction 4.2.73) is not suitably continuous, and so does not provide an ∞ -functor, as indicated (see Observation 4.2.61).³² \square

Complementary to the above primary results relating meshes and their maps to trusses and their maps, there is a relationship of meshes and their bordisms (see Definition 4.1.100) to trusses and their bordisms (see Notations 2.3.20 and 2.3.24 and Lemma 2.3.25), as follows.

THEOREM 4.2.5 (Weak equivalence of mesh and truss bordisms). *The fundamental truss functor induces a trivial fibration of quasicategories*

$$\mathbf{MBord}_n \xrightarrow{\mathbb{I}_{\mathbb{T}}} \mathbf{TBord}^n$$

and thus provides an equivalence between the quasicategory of n -meshes and their bordisms and the 1-category of n -trusses and their bordisms.

Here we regard the 1-category \mathbf{TBord}^n of trusses and their bordisms as a quasicategory by implicitly taking its simplicial nerve. The indicated fibration of quasicategories is given on k -simplices by the fundamental truss functor on mesh bundles over the stratified k -simplex. Crucially, this result concerns only mesh and truss *bordisms* and so is unaffected by the non-invertible higher morphisms that arise in considering mesh and truss *maps* (see Footnote 32). This result is established after the mesh and truss map equivalences in Section 4.2.6.

REMARK 4.2.6 (Mapping cylinders as mesh bordisms). Recall from Construction 2.1.68 that to certain truss maps, there were associated ‘mapping cylinder’ truss bordisms. The above results and discussion combine to provide a relationship between mesh maps and mesh bordisms, parallel to that earlier relationship between truss maps and truss bordisms. To an appropriate mesh map, we expect to be able to form the geometric mapping cylinder to obtain a mesh bordism; formally, we combine the homotopy coherent nerve N^{hc} (see [Qui67, §II.3] and [Joy07]) of the fundamental truss ∞ -functor (from Remark 4.2.4), with the nerve of the truss mapping cylinder, and the inverse of the bordism fundamental truss equivalence (from Theorem 4.2.5), to obtain

³²The mixed fundamental truss ∞ -functor is nevertheless a weak equivalence in an appropriate sense. That sense, accounting for *non-invertible* higher morphisms, is $(\infty, 2)$ -categorical: the category of stratified spaces, and therefore meshes, is secretly $(\infty, 2)$ -categorical, and the category of posets, and therefore trusses, is not-so-secretly 2-categorical. Indeed, the $k\mathbf{Top}$ -enrichment (crucially not a \mathbf{Top} -enrichment) of the category of posets is a topological simulacrum of the presence of non-invertible 2-morphisms—*entrance* paths in non-Hausdorff spaces need not be invertible. To avoid the technicalities and diversions of $(\infty, 2)$ -categories, we must restrict attention to the rigid cases of open or closed meshes and trusses.

the ‘mesh mapping cylinder’ \mathcal{Cyl} , as follows:

$$\begin{array}{ccc}
 N\mathbf{Tr}_1^{s,\partial} & \xrightarrow{N\mathcal{Cyl}} & N\mathbf{T}\mathbf{Bord}_1 \\
 N^{\text{hc}}\mathbb{P}_T \uparrow & & \mathbb{P}_T \uparrow \sim \\
 N^{\text{hc}}\mathbf{Mesh}_1^{s,\partial} & \xrightarrow{\mathcal{Cyl}} & \mathbf{MBord}_1
 \end{array}$$

Here, $\mathbf{Mesh}_1^{s,\partial}$ denotes the wide subcategory of \mathbf{Mesh}_1 whose morphisms are the singular maps that preserve singular endpoints. (That the functor $N^{\text{hc}}\mathbb{P}_T$ restricted to $\mathbf{Mesh}_1^{s,\partial}$ indeed lands in $N\mathbf{Tr}_1^{s,\partial}$ requires consideration, cf. [Lemma 2.3.71](#) and [Proposition 4.2.18](#) and its corollaries.) A similar diagram constructs the ‘mesh mapping cocylinder’ functor $\text{co}\mathcal{Cyl} : N^{\text{hc}}(\mathbf{Mesh}_1^{r,\partial})^{\text{op}} \rightarrow \mathbf{MBord}_1$. —

We conclude by previewing two applications of the equivalences of meshes and trusses, namely to the classification of subdivisions of framed cells, and to the dualization of meshes.

Composing the weak equivalence of closed meshes and closed trusses from [Theorem 4.2.1](#), with the equivalence of closed trusses and collapsible framed regular cell complexes from [Theorem 3.1.2](#), we obtain the composite weak equivalence

$$\begin{array}{ccc}
 \bar{\mathbf{Mesh}}_n & \begin{array}{c} \xrightarrow{\mathbb{P}_T} \\ \xleftarrow{\nabla_C \circ \mathbb{P}_T} \\ \xrightarrow{\|\cdot\|_M} \\ \xleftarrow{\|\cdot\|_M \circ f_T} \end{array} & \bar{\mathbf{Tr}}_n & \begin{array}{c} \xleftarrow{\nabla_C} \\ \xrightarrow{f_T} \end{array} & \mathbf{CollFrCellCplx}_n
 \end{array}$$

TERMINOLOGY 4.2.7 (Mesh-to-cell gradient and cell-to-mesh realization). We denote the composite functors in the above equivalence by

$$\begin{aligned}
 \nabla_{\text{MC}} &:= \nabla_C \circ \mathbb{P}_T \\
 \|\cdot\|_{\text{CM}} &:= \|\cdot\|_M \circ f_T
 \end{aligned}$$

and call them the ‘mesh-to-cell (gradient) functor’ and the ‘cell-to-mesh (realization) functor’, respectively. —

We can leverage the cell-to-mesh realization functor to provide a notion of framed subdivision of a framed regular cell: a framed cell complex framed subdivides a framed cell when equipped with a stratified coarsening between their cell-to-mesh realizations, which on every cell of the complex is a map of meshes (see [Definition 4.2.87](#)). Quite unlike non-framed subdivisions, these framed subdivisions are combinatorially classifiable, as follows.

THEOREM 4.2.8 (Classifying subdivisions of framed cells). *A framed regular cell complex Y framed subdivides a framed regular cell X exactly when*

◊ Transport this arrow fix to other similar asymmetric curved arrows.

◊ The label positioning in the above display isn’t great, but small tweaking does not fix it.

the framed complex Y is the cell gradient $\nabla_{\mathbb{C}} T$ of a truss T that combinatorially subdivides a truss block B whose cell gradient $\nabla_{\mathbb{C}} B$ is the framed cell X .

This result is explained, illustrated, and established in [Section 4.2.6.1](#).

Finally, the duality of closed and open trusses may be transported across the equivalence of meshes and trusses to provide a duality of closed and open meshes.

COROLLARY 4.2.9 (Dualization of meshes). *There is a dualization weak equivalence between the ∞ -categories of closed n -meshes and open n -meshes:*

$$\dagger : \bar{\mathcal{M}}esh_n \simeq \mathring{\mathcal{M}}esh_n : \dagger \quad .$$

This result is established and discussed in [Section 4.2.6.2](#). Notice that framed regular cell complexes provided a target context for topological realization of *closed* trusses, but there was no evident corresponding cell-like topological realization of *open* trusses. The constructible stratified framework of meshes, by contrast, conveniently accommodates realizations of both closed and open trusses and of course the duality between them.

4.2.2. Fundamental trusses. We will now construct the fundamental truss functors from various categories of n -meshes to corresponding categories of n -trusses. We first address the foundational case of the functor of 1-categories

$$\mathbb{I}_{\top} : \mathcal{M}esh_n(B, g) \rightarrow \mathcal{T}rs_n(\mathbb{I}g).$$

We then observe that that functor is suitably continuous on hom-spaces, and so provides an ∞ -functor

$$\mathbb{I}_{\top} : \mathcal{M}esh_n(B, g) \rightarrow \mathcal{I}ts_n(\mathbb{I}g).$$

Of course, the functor $\mathcal{I}ts_n(\mathbb{I}g) \rightarrow \mathcal{T}rs_n(\mathbb{I}g)$ (from the $k\mathbf{Top}$ -enriched category to the discrete category) is not continuous on hom-spaces, but it is continuous when restricted either to the subcategory of closed trusses and singular maps, or to the subcategory of open trusses and regular maps. We will therefore obtain, as composites, fundamental truss ∞ -functors, from the ∞ -category of (closed or open) meshes to the discrete category of (closed or open) trusses:

$$\begin{aligned} \mathbb{I}_{\top} : \bar{\mathcal{M}}esh_n(B, g) &\rightarrow \bar{\mathcal{T}}rs_n(\mathbb{I}g) \\ \mathbb{I}_{\top} : \mathring{\mathcal{M}}esh_n(B, g) &\rightarrow \mathring{\mathcal{T}}rs_n(\mathbb{I}g). \end{aligned}$$

The construction of all these fundamental truss functors is mainly straightforward—take the fundamental poset of each stage—but we will need to check that the resulting towers of posets indeed satisfy the conditions for being trusses, truss bordisms, and truss bundles accordingly.

The following examples, collected from past figures, serve as an informal visual guide to the correspondence of meshes and their fundamental trusses, and can be kept in mind during the detailed constructions and arguments to follow.

EXAMPLE 4.2.10 (Fundamental trusses and truss bundles). Recall from Figure 4.2 the three linear 1-meshes in the middle and the two trivial 1-meshes on the left that are embedded in \mathbb{R}^1 ; the corresponding fundamental 1-trusses are the three linear 1-trusses in the middle and the two trivial 1-trusses on the left of Figure 2.4. Further recall from Figure 4.3 the various types of maps of 1-meshes; for the singular, regular, and balanced cases, the induced maps of fundamental 1-trusses are those shown in Figure 2.6.

Next recall from Figure 4.4 a 1-mesh bordism (i.e. a 1-mesh bundle over the stratified 1-simplex); the corresponding fundamental 1-truss bordism was depicted in Figure 2.9. The six local forms of 1-mesh bordisms depicted in Figure 4.7 have as corresponding fundamental 1-truss bordisms the six local forms in Figure 2.12. More generally, recall from Figure 4.5 the 1-mesh bundle over the stratified realization of a poset; the corresponding fundamental 1-truss bundle was shown in Figure 2.19.

Furthermore, recall from Figure 2.42 both a 2-mesh and its corresponding fundamental 2-truss, and finally, recall from Figure 2.41 both a 3-mesh and its corresponding fundamental 3-truss. \square

SYNOPSIS. We construct the fundamental n -truss bundle associated to an n -mesh bundle, and observe that association provides a functor from the 1-category of mesh bundles to the 1-category of truss bundles. We then show that functor is continuous with respect to a topological enrichment, and, after restriction to closed or open meshes, yields an ∞ -functor from the ∞ -category of meshes to the discrete category of trusses.

4.2.2.1. Fundamental trusses as an ordinary functor. We detail the construction of the fundamental truss functor as an ordinary functor, from the 1-category of mesh bundles to the 1-category of truss bundles.

CONSTRUCTION 4.2.11 (Fundamental 1-truss bundles). Given a 1-mesh bundle $p : (M, f) \rightarrow (B, g)$, we will equip the fundamental poset map $\mathbb{P}p : \mathbb{P}f \rightarrow \mathbb{P}g$ with the structure of a 1-truss bundle, yielding the ‘fundamental 1-truss bundle’ $\mathbb{P}_\top(p)$ of the 1-mesh bundle p .

We first describe the 1-truss structure on the fibers of the poset map $\mathbb{P}p$. Trivialize the 1-mesh bundle p over a base stratum s , by an isomorphism $p^{-1}(s) \cong s \times \mathbf{fib}(s)$; here $\mathbf{fib}(s)$ is the fiber 1-mesh over the stratum s , see Observation 4.1.34. Note that the fiber of the fundamental poset map over the stratum s is simply, and canonically, the fundamental poset of the fiber 1-mesh: $(\mathbb{P}p)^{-1}(s) \cong \mathbb{P}(p^{-1}(s)) \cong \mathbb{P}(\mathbf{fib}(s))$. Equip this fiber $(\mathbb{P}p)^{-1}(s)$ with a frame order \preceq that orders strata according to the 1-framing of the 1-mesh $\mathbf{fib}(s)$, and equip the fiber with a dimension map $\dim : (\mathbb{P}p)^{-1}(s) \rightarrow [1]^{\text{op}}$ that sends each element $t \in (\mathbb{P}p)^{-1}(s)$ to the fiber dimension $\mathbf{fibdim}(\tilde{t})$ of the corresponding fiber stratum $\tilde{t} \in \mathbf{fib}(s)$. We subsequently will tend to elide, even notationally, the distinction between a poset element $t \in (\mathbb{P}p)^{-1}(s)$ and its corresponding stratum $t \equiv \tilde{t} \in \mathbf{fib}(s)$.

We next and finally check that the poset map $\mathbb{P}p$, now with its 1-truss point fibers, in fact has 1-truss bordism fibers over arrows of the base poset.

Specifically, given an entrance path $r \rightarrow s$ in the base poset $\mathbb{F}g$, we need that the functorial relation $R = (\mathbb{F}p)^{-1}(r \rightarrow s) : (\mathbb{F}p)^{-1}(r) \rightarrow (\mathbb{F}p)^{-1}(s)$ is a 1-truss bordism. Constructibility of the mesh bundle constrains this relation as follows. Let $t \in (\mathbb{F}p)^{-1}(r)$ be an element in the generic fiber. When t is singular, by constructibility there is a unique element $u \in (\mathbb{F}p)^{-1}(s)$ of the special fiber, such that $R(t, u)$ holds, and u is moreover singular. Otherwise for t a regular element of the general fiber and u an element of the special fiber, the relation $R(t, u)$ holds exactly when the following two implications both hold: first, when the stratum t is bounded above by a singular stratum t^+ , then there is a frame order relation $u \preceq u^+$ in the special fiber, for a stratum u^+ with relation $R(t^+, u^+)$; second, when the stratum t is bounded below by a singular stratum t^- , then there is a frame order relation $u^- \preceq u$ in the special fiber, for a stratum u^- with relation $R(t^-, u^-)$. (If the stratum t is bounded neither above nor below, then it is in fact related to every element of the special fiber.) Altogether, this relation is specified as in the construction of singular-determined 1-truss bordisms in Lemma 2.1.63, and in particular is indeed a 1-truss bordism as required. \square

DEFINITION 4.2.12 (Fundamental truss bundles). For an n -mesh bundle p over the stratification (B, g) , given by the sequence of 1-mesh bundles

$$(M_n, f_n) \xrightarrow{p_n} (M_{n-1}, f_{n-1}) \xrightarrow{p_{n-1}} \cdots \xrightarrow{p_2} (M_1, f_1) \xrightarrow{p_1} (M_0, f_0) = (B, g),$$

its **fundamental truss bundle** $\mathbb{F}_\top(p)$ is the n -truss bundle over $\mathbb{F}g$, given by the sequence of 1-truss bundles

$$\mathbb{F}(f_n) \xrightarrow{\mathbb{F}_\top(p_n)} \mathbb{F}(f_{n-1}) \xrightarrow{\mathbb{F}_\top(p_{n-1})} \cdots \xrightarrow{\mathbb{F}_\top(p_2)} \mathbb{F}(f_1) \xrightarrow{\mathbb{F}_\top(p_1)} \mathbb{F}(f_0) = \mathbb{F}(g),$$

where each $\mathbb{F}_\top(p_i)$ is the fundamental 1-truss bundle of the 1-mesh bundle p_i . \square

DEFINITION 4.2.13 (Fundamental truss bundle maps). For a mesh bundle map $F : p \rightarrow q$ between an n -mesh bundle p over (B, g) and an n -mesh bundle q over (C, h) , with components $F_i : (M_i, f_i) \rightarrow (N_i, g_i)$, the **fundamental truss bundle map** $\mathbb{F}_\top F : \mathbb{F}_\top(p) \rightarrow \mathbb{F}_\top(q)$ is the truss bundle map with components $(\mathbb{F}_\top F)_i = \mathbb{F}(F_i) : \mathbb{F}(f_i) \rightarrow \mathbb{F}(g_i)$. \square

NOTATION 4.2.14 (The fundamental truss functor). The previous two definitions together give the fundamental truss functor $\mathbb{F}_\top : \mathbf{MeshBun}_n \rightarrow \mathbf{TrsBun}_n$ from mesh bundles to truss bundles. That functor restricts to the fundamental truss functor $\mathbb{F}_\top : \mathbf{Mesh}_n(B, g) \rightarrow \mathbf{Trs}_n(\mathbb{F}g)$ from mesh bundles over the stratification (B, g) to truss bundles over the poset $\mathbb{F}g$. \square

OBSERVATION 4.2.15 (The fundamental truss functor preserves pullbacks). Recall from Construction 4.1.93 and Construction 2.3.54 the notions of pullback of n -mesh bundles and pullback of n -truss bundles respectively. The fundamental truss functor preserves pullbacks in the sense that the fundamental truss of the pullback is the pullback of the fundamental truss:

$\mathbb{P}_\top(G^*p) = (\mathbb{P}G)^*\mathbb{P}_\top(p)$; here p is an n -mesh bundle over (B, g) , and $G : (C, f) \rightarrow (B, g)$ is a map of stratifications. ---

4.2.2.2. Fundamental trusses as an ∞ -functor. We now upgrade the fundamental truss functor to an ∞ -functor, with target either the $k\text{Top}$ -enriched category of trusses or, when restricted to closed or open mesh bundles, the corresponding discrete categories of trusses.

Recall from Notation 4.1.97 that $\text{Mesh}_n(B, g)$ denotes the Top -enriched category of n -mesh bundles over the stratification (B, g) , with the hom-sets topologized as subspaces of the literal mapping spaces of the total spaces of the mesh bundle towers. Recall further from Remark 2.3.39 that $\mathcal{T}\mathcal{r}\mathcal{u}\mathcal{s}_n(X)$ denotes the $k\text{Top}$ -enriched category of n -truss bundles over the poset X , with the hom-sets given the specialization topology of the poset of truss bundle maps and natural transformations of their total posets.

The fundamental truss provides an ∞ -functor (between $k\text{Top}$ -enriched categories) as follows.

PROPOSITION 4.2.16 (The fundamental truss as an enriched functor). *The fundamental truss induces an ∞ -functor $\mathbb{P}_\top : \text{Mesh}_n(B, g) \rightarrow \mathcal{T}\mathcal{r}\mathcal{u}\mathcal{s}_n(\mathbb{P}g)$.*

PROOF. One needs to check that the hom-space map $\mathbb{P}_\top : \text{Mesh}_n(B, g)(M, N) \rightarrow \mathcal{T}\mathcal{r}\mathcal{u}\mathcal{s}_n(\mathbb{P}g)(\mathbb{P}_\top M, \mathbb{P}_\top N)$ is continuous. That follows from the proof of the continuity on hom-spaces of the functor $\mathbb{P} : \text{Strat}_{\mathcal{E}} \rightarrow \mathcal{P}\mathcal{o}\mathcal{s}_{\mathcal{E}}$, detailed in Construction B.2.20. (Note as in Remark B.2.19 that the $k\text{Top}$ -enrichment of $\mathcal{P}\mathcal{o}\mathcal{s}_{\mathcal{E}}$ is indeed the specialization topology on poset maps and natural transformations.) \square

REMARK 4.2.17 (Non-invertible 2-morphisms of trusses and meshes). As mentioned, the preceding functor is only $k\text{Top}$ -enriched and not Top -enriched, since the hom-spaces in the category $\mathcal{T}\mathcal{r}\mathcal{u}\mathcal{s}_n$ (and similarly $\mathcal{T}\mathcal{r}\mathcal{u}\mathcal{s}_n(X)$) are not weak Hausdorff. These hom $k\text{Top}$ spaces, qua spaces, do not accurately represent the higher-categorical structure of trusses: natural transformations of maps of trusses provide in general *non-invertible* 2-morphisms, which are not especially well represented in the associated specialization topology.

Though we introduced Mesh_n (and similarly $\text{Mesh}_n(B, g)$) as an ∞ -category (i.e. $(\infty, 1)$ -category), in fact entrance path deformations between stratified maps provide non-invertible 2-morphisms of meshes, as well.³³ Thus, while one could show that the functor \mathbb{P}_\top in Proposition 4.2.16 is a weak equivalence in some appropriate sense, a more principled approach would be to establish an equivalence $\text{Mesh}_n \simeq \mathcal{T}\mathcal{r}\mathcal{u}\mathcal{s}_n$ of $(\infty, 2)$ -categories; we quite forgo that here.

We are at luxury to defer an $(\infty, 2)$ -categorical treatment because, in the cases of our primary attention, namely closed trusses and singular maps or open trusses and regular maps, non-invertible 2-morphisms are conspicuously absent; see the next proposition. ---

³³Similarly, entrance path deformations provide higher morphisms for stratifications more generally; see Remark B.3.19.

PROPOSITION 4.2.18 (Rigidity of closed or open truss bundles). *The subspace of singular maps in any hom-space between closed truss bundles, in the $k\mathbf{Top}$ -enriched category $\mathcal{T}\mathcal{r}_n(X)$, is discrete. Similarly, the subspace of regular maps in any hom-space between open truss bundles, again in the $k\mathbf{Top}$ -enriched category $\mathcal{T}\mathcal{r}_n(X)$, is discrete.*

PROOF. These statements follow from the fact, established in Lemma 2.3.72, that singular maps of closed truss bundles, similarly regular maps of open truss bundles, over a fixed base poset, do not admit any non-trivial natural transformations. \square

COROLLARY 4.2.19 (Rigidity of the fundamental truss for closed or open mesh bundles). *The fundamental truss functor restricts to ∞ -functors $\mathbb{I}_\top : \bar{\mathcal{M}}esh_n(B, g) \rightarrow \bar{\mathcal{T}}rs_n(\mathbb{I}g)$ and $\mathbb{I}_\top : \mathring{\mathcal{M}}esh_n(B, g) \rightarrow \mathring{\mathcal{T}}rs_n(\mathbb{I}g)$.*

COROLLARY 4.2.20 (Rigidity of the fundamental truss for closed or open meshes). *The fundamental truss functor restricts to ∞ -functors $\mathbb{I}_\top : \bar{\mathcal{M}}esh_n \rightarrow \bar{\mathcal{T}}rs_n$ and $\mathbb{I}_\top : \mathring{\mathcal{M}}esh_n \rightarrow \mathring{\mathcal{T}}rs_n$.*

Lemma 2.3.72 suggests two other settings for ∞ -categorical fundamental truss functors. Note that the fundamental truss construction sends degeneracies of meshes to degeneracies of trusses, and coarsenings of meshes to coarsenings of trusses; thus there are ordinary functors $\mathbb{I}_\top : \mathcal{M}esh_n^{\text{deg}} \rightarrow \mathcal{T}rs_n^{\text{deg}}$ and $\mathbb{I}_\top : \mathcal{M}esh_n^{\text{crs}} \rightarrow \mathcal{T}rs_n^{\text{crs}}$ (see Notation 2.3.66). Again by the rigidity of hom posets for these truss categories, we have the following consequence.

OBSERVATION 4.2.21 (Rigidity of the fundamental truss for degeneracies and coarsenings). *The fundamental truss functor restricts to ∞ -functors $\mathbb{I}_\top : \mathring{\mathcal{M}}esh_n^{\text{deg}} \rightarrow \mathring{\mathcal{T}}rs_n^{\text{deg}}$ and $\mathbb{I}_\top : \mathring{\mathcal{M}}esh_n^{\text{crs}} \rightarrow \mathring{\mathcal{T}}rs_n^{\text{crs}}$ (see Notation 4.1.99). \square*

The restricted functors in Corollary 4.2.19 (and similarly in Corollary 4.2.20 and Observation 4.2.21) are in fact weak equivalences of ∞ -categories. In the next two sections we establish the two core ingredients for those equivalences, namely that the fundamental truss functor is *essentially injective* and *weakly faithful*.

4.2.3. Essential injectivity of the fundamental truss functor. Of course, given n -meshes M and M' , by the functoriality of the fundamental truss functor \mathbb{I}_\top , if the meshes are isomorphic $M \cong M'$ then the fundamental trusses are isomorphic $\mathbb{I}_\top(M) = \mathbb{I}_\top(M')$. (We write equality for (balanced) isomorphism since truss isomorphisms are necessarily unique.) Working toward establishing that the fundamental truss functor, suitably restricted, is an equivalence, we will next show that when the fundamental trusses are isomorphic, the meshes were too, i.e. the functor \mathbb{I}_\top is *essentially injective*. We record this result, also for mesh bundles, as follows.

PROPOSITION 4.2.22 (Essential injectivity). *For a cellulable stratification (B, g) , the functor $\mathbb{I}_\top : \mathcal{M}esh_n(B, g) \rightarrow \mathcal{T}rs_n(\mathbb{I}g)$ is essentially injective; that is, given n -mesh bundles p and p' over the stratification (B, g) , if the*

fundamental trusses are isomorphic, $\mathbb{P}_\top(p) = \mathbb{P}_\top(p')$, then the mesh bundles are isomorphic, $p \cong p'$.

The proof of this proposition will occupy the whole of this subsection. The properties established during the construction of the mesh bundle isomorphism (specifically the continuity of the isomorphism for families of mesh bundles) will be reused in our subsequent proof of the weak faithfulness of the fundamental truss functor.

OBSERVATION 4.2.23 (Essential injectivity for degeneracies and coarsenings). Note that any isomorphism of n -meshes is both a degeneracy and a coarsening. Therefore the following proof of essentially injective of the fundamental truss functor specializes to give the essential injectivity of the restrictions $\mathbb{P}_\top : \text{Mesh}_n^{\text{deg}} \rightarrow \text{Trs}_n^{\text{deg}}$ and $\mathbb{P}_\top : \text{Mesh}_n^{\text{crs}} \rightarrow \text{Trs}_n^{\text{crs}}$. \square

SYNOPSIS. We show that it suffices to establish essential injectivity of the fundamental truss functor for bundles over cellular bases, then for 1-mesh bundles, and finally for closed bundles. We then introduce regular contours of 1-mesh bundles, and catchment areas and radial catchment paths of cellular stratifications. Equipped with those technical notions, we construct the desired closed 1-mesh bundle isomorphism via affine interpolations. Finally, we observe the construction of these mesh bundle isomorphisms is continuous in families.

4.2.3.1. \star Reduction to closed 1-mesh bundles over a cellular base.

By several reduction steps, we show that it suffices to prove essential injectivity for closed 1-mesh bundles over a cellular base. We begin with the reduction from the general n -mesh bundle case to that case over a cellular base.

OBSERVATION 4.2.24 (Reduction to cellular base). For cellulable (B, g) , pick a refinement $G : (B, c) \rightarrow (B, g)$ by a cellular stratification (B, c) . Pullback (see Construction 4.1.93) the bundles p and p' to n -mesh bundles G^*p and G^*p' over (B, c) . The assumption $\mathbb{P}_\top(p) = \mathbb{P}_\top(p')$ (in the statement of Proposition 4.2.22) implies that $\mathbb{P}_\top(G^*p) = \mathbb{P}_\top(G^*p')$ (see Observation 4.2.15). Any n -mesh bundle isomorphism $G^*p \cong G^*p'$ that fixes the base stratification (B, c) will induce an n -mesh bundle isomorphism $p \cong p'$. Thus, it suffices to prove Proposition 4.2.22 for cellular base stratifications. \square

We will therefore now assume our base stratification (B, g) is cellular.

Next, arguing inductively, we find that it further suffices to prove essential injectivity for the case of 1-mesh bundles.

OBSERVATION 4.2.25 (Reduction to 1-mesh bundles). Consider n -mesh bundles p and p' , with component 1-mesh bundles $p_i : (M_i, f_i) \rightarrow (M_{i-1}, f_{i-1})$ and $p'_i : (M'_i, f'_i) \rightarrow (M'_{i-1}, f'_{i-1})$, respectively, where $(M_0, f_0) = (B, g) = (M'_0, f'_0)$. Suppose we have $\mathbb{P}_\top(p) = \mathbb{P}_\top(p')$, as assumed in Proposition 4.2.22. That implies $(\mathbb{P}_\top(p))_{<n} = (\mathbb{P}_\top(p'))_{<n}$, and so, assuming the proposition inductively, we have an isomorphism $G : p_{<n} \cong p'_{<n}$ of truncated mesh bundles. Set the n -mesh bundle G^*p' to be the pullback of p' along G

(see Construction 4.1.93); denote the top 1-mesh bundle of G^*p' by $\tilde{p}_n : (\tilde{M}_n, \tilde{f}_n) \rightarrow (M_{n-1}, f_{n-1})$ and denote the canonical map $(\tilde{M}_n, \tilde{f}_n) \rightarrow (M'_n, f'_n)$ by F , as shown in the next diagram.

$$\begin{array}{ccc} \tilde{f}_n & \xrightarrow{F} & f'_n \\ \tilde{p}_n \downarrow & \lrcorner & \downarrow p'_n \\ f_{n-1} & \xrightarrow{G_{n-1}} & f'_{n-1} \end{array}$$

Since by assumption G is an isomorphism, note that F is also an isomorphism. To prove Proposition 4.2.22, it remains only to construct a bundle isomorphism $\kappa_{\tilde{p}_n}^{p_n}$, as shown below.

$$\begin{array}{ccc} f_n & \xrightarrow[\sim]{\kappa_{\tilde{p}_n}^{p_n}} & \tilde{f}_n \\ p_n \searrow & & \swarrow \tilde{p}_n \\ & f_{n-1} & \end{array}$$

The required bundle isomorphism $\kappa_{\tilde{p}_n}^{p_n}$ is provided by the next proposition. (Note that since cellularity lifts (see Lemma 4.1.64) and since (B, g) is cellular, the stratification f_{n-1} itself is cellular.) —

PROPOSITION 4.2.26 (Essential injectivity for 1-mesh bundles). *For a cellular stratification (B, g) and 1-mesh bundles $p : (M, f) \rightarrow (B, g)$ and $\tilde{p} : (\tilde{M}, \tilde{f}) \rightarrow (B, g)$ such that $\mathbb{P}_\top(p) = \mathbb{P}_\top(\tilde{p})$, there is a 1-mesh bundle isomorphism $\kappa_{\tilde{p}}^p : p \cong \tilde{p}$ that fixes the base (B, g) .*

The proof of this statement will take the remainder of this subsection. As a preliminary matter we further reduce to the closed case as follows.

OBSERVATION 4.2.27 (Reduction to closed bundles). Fiberwise compactifying both bundles in the preceding proposition, we obtain closed 1-mesh bundles \bar{p} and $\bar{\tilde{p}}$ (see Construction 4.1.58). These bundles certainly still admit an isomorphism $\mathbb{P}_\top(\bar{p}) = \mathbb{P}_\top(\bar{\tilde{p}})$. Moreover, if we find a bundle isomorphism $\kappa : \bar{p} \cong \bar{\tilde{p}}$, then we obtain a bundle isomorphism $\kappa : p \cong \tilde{p}$ by restriction, as required. Therefore it suffices to prove Proposition 4.2.26 for closed 1-mesh bundles over a cellular base stratification (B, g) . —

Fix closed 1-mesh bundles p and \tilde{p} as in Proposition 4.2.26. The construction of the prospective bundle isomorphism $\kappa_{\tilde{p}}^p : f \cong \tilde{f}$ requires care; as motivation for our approach, we first discuss how *not* to construct $\kappa_{\tilde{p}}^p$. One would like to define a stratified homeomorphism $\kappa_{\tilde{p}}^p : f \cong \tilde{f}$ fiberwise; naively one might imagine, fiber by fiber, mapping point strata to point strata and extending linearly to obtain the map on the intervening interval strata (recall the fibers in 1-mesh bundles inherit, via their 1-framed realization embedding, a linear structure from the standard linear structure of \mathbb{R}). However, when traversing an entrance path between two strata $r \rightarrow s$ in the base (B, g) , new

Minor: exact logic of above arg [Fixed the logic flow a little, otherwise confirmed as sound]

singular strata can appear in the special fiber (of either the source or target bundle) over s , that were not present in the generic fiber over r . Because of these creation paths, the rudimentary linear interpolation construction fails; we illustrate the issue in the following example.

EXAMPLE 4.2.28 (Failure of continuity in fiberwise linear interpolation). Consider the bundles $p : (M, f) \rightarrow (B, g)$ and $\tilde{p} : (\tilde{M}, \tilde{f}) \rightarrow (B, g)$ shown in Figure 4.18, whose fundamental 1-truss bundles coincide. We depict these bundles, via their 1-framed realizations, as embedded in $B \times \mathbb{R}$; we indicate by a green squiggle an entrance path in the base (B, g) , together with a generic fiber (also in green) and a special fiber (in purple) in both p and \tilde{p} . If we were to build a bundle isomorphism fiberwise by first identifying the point strata of fibers (as indicated by the mappings on the right) and then linearly interpolating these mappings on interval strata, we would end up with a *discontinuous* bundle isomorphism between p and \tilde{p} . \square

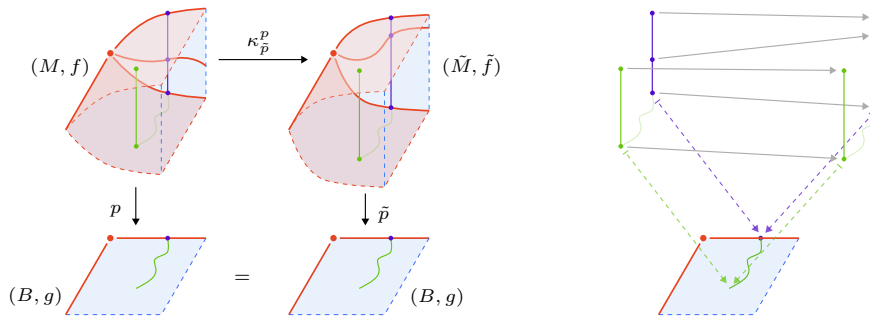

FIGURE 4.18. Failure of continuity of fiberwise interpolation of mesh bundle isomorphisms.

By contrast, our strategy to ensure continuity in the construction of the bundle isomorphism $\kappa_{\tilde{p}}^p$ will be to use *affine combinations* of maps on generic and special fibers when traversing certain entrance paths.

4.2.3.2. ★ Regular contours and catchment areas. We first introduce a notion of ‘regular contours’, which will delineate the boundary strata in the base stratification over which we need to use an affine combination (as opposed to a simple linear interpolation) for the desired mesh bundle isomorphism. We then describe ‘catchment areas’, which function as a sort of tubular neighborhoods in the base stratification; we will later on define the bundle isomorphism via a combination of maps over a generic fiber on the boundary of the catchment area and a special fiber at the core of the area. Recall that we assume the base stratification (B, g) is cellular, and fix a closed 1-mesh bundle $p : (M, f) \rightarrow (B, g)$.

CONSTRUCTION 4.2.29 (Regular contours). Consider a regular stratum s of the stratification f , lying over a stratum $r = p(s)$ of the base stratification

g (note, by the assumption on (B, g) , that r is a cell). The ‘regular contour of the stratum s ’, denoted $c_s \subset \partial r$ (where $\partial r = \bar{r} \setminus r$), is the union of strata t in the boundary of r , for which there exists a regular stratum u lying over t , such that u lies in the boundary of s . —

EXAMPLE 4.2.30 (Regular contours). In Figure 4.19, we highlight the regular contour of a chosen stratum s (for the bundle p from Figure 4.18). —

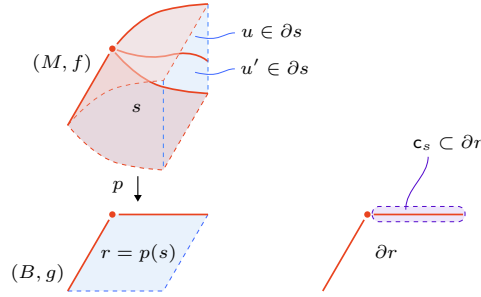

FIGURE 4.19. The regular contour of a regular stratum.

OBSERVATION 4.2.31 (Regular contours only depend on truss structure). If $\tilde{p} : (\tilde{M}, \tilde{f}) \rightarrow (B, g)$ is another closed 1-mesh bundle over (B, g) and $\Pi_{\mathbb{T}}(p) = \Pi_{\mathbb{T}}(\tilde{p})$, we may identify strata s of f with strata \tilde{s} of \tilde{f} , and then the regular contours c_s and $c_{\tilde{s}}$ of corresponding strata coincide as subspaces of the base B . —

With the notion of regular contours established, we turn to the separate matter of catchment areas.

CONSTRUCTION 4.2.32 (Catchment areas and radial catchment paths). Let r be a stratum in (B, g) . Since (B, g) is cellular, it includes as a constructible substratification into a regular cell complex X . Consider the closed cell R obtained as the closure of the cell r in X (and stratify R by its cells); note that $\partial r \subset \partial R$ where $\partial R = R \setminus r$ and again $\partial r = \bar{r} \setminus r$. We endow R with simplicial structure via an identification $R \cong \|\Pi R\|$. We say $x \in r$ lies in the ‘catchment area C_b of an open cell $b \subset \partial r$ ’ if it lies in the open simplicial star of the vertex corresponding to b , and does not lie in the open simplicial star of a vertex corresponding to a higher-dimensional open cell $b' \subset \partial r$. Set the ‘closed catchment area \bar{C}_b of b ’ to be the closure $\bar{C}_b \subset r$ of C_b inside the open cell r ; note that the stratum b is not contained in its closed catchment area \bar{C}_b . The radial projections of cellular stars³⁴ (of cells b in ∂r) restrict to ‘catchment projections’ $\pi_b : \bar{C}_b \rightarrow b$. The radial lines of such a projection

³⁴See Terminology B.3.28 for a definition and discussion of cellular stars. Note that $\text{star}(b) \setminus \partial b$ is the product $\overline{\text{cone}}(\text{link}(b)) \times b$. The radial projection is simply induced by the radial projection $\overline{\text{cone}}(\text{link}(b)) \rightarrow \{1\}$ of the closed cone to its cone point; see Terminology B.3.1.

decompose \overline{C}_b into ‘radial catchment path’ families $\overline{C}_b \cong F_b \times [0, 1) \hookrightarrow R$, where F_b is the boundary of the closed cellular star around b , but with the boundary ∂b removed. (Note that as each radial catchment path approaches 1 in the decomposition $F_b \times [0, 1)$, the path in \overline{C}_b is approaching the stratum b .) See the next example and figure for an illustration. \square

EXAMPLE 4.2.33 (Catchment areas and catchment paths). The previous construction of catchment areas and radial catchment paths is illustrated in Figure 4.20, in three cases. The left case is the stratification (B, g) with the stratum r from Figure 4.19. In the middle case, the closed cell R is again the square with its indicated stratification, and the stratum r is again the open 2-cell, but the stratification (B, g) is the union of the stratum r and the three colored boundary strata. Similarly in the right case, the stratification (B, g) is the union of the stratum r and the single colored boundary stratum. In each case, we highlight the (open) catchment areas and their decomposition into catchment path families, with catchment paths oriented from 0 to 1. \square

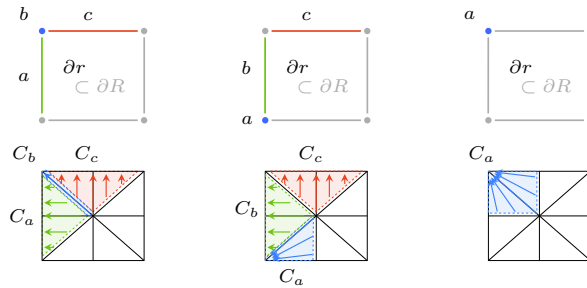

FIGURE 4.20. Catchment areas for cells and their decomposition into radial catchment paths.

REMARK 4.2.34 (Choice of catchment structure). Note that the preceding construction depends on certain choices, namely a choice of regular cell complex X and the identification of closed cells with the simplicial realization of the cells’ fundamental posets. Henceforth when working with cellular stratifications (B, g) , we will implicitly fix such a regular complex and identifications, and conceive of these as providing the stratification with a ‘regular simplicial structure’. \square

4.2.3.3. ★ Constructing the bundle isomorphism. Equipped with the notions of catchment areas and radial catchment paths, we can proceed to construct the bundle isomorphism $\kappa_{\tilde{p}}^p$, and complete the proofs of both Proposition 4.2.26 and Proposition 4.2.22.

CONSTRUCTION 4.2.35 (The bundle isomorphism for essential injectivity). Consider closed 1-mesh bundles $p : (M, f) \rightarrow (B, g)$ and $\tilde{p} : (\tilde{M}, \tilde{f}) \rightarrow (B, g)$, with a cellular base (B, g) , and such that $\mathbb{I}_{\top}(p) = \mathbb{I}_{\top}(\tilde{p})$. We will define a bundle isomorphism $\kappa_{\tilde{p}}^p$ fiberwise by maps

$$\kappa_{\tilde{p}}^p(x, -) : p^{-1}(x) \rightarrow \tilde{p}^{-1}(x)$$

over points $x \in r$, where r is a stratum in the base g . We provide the definition inductively in $\dim(r)$.

If $\dim(r) = 0$ then the fiber isomorphism $\kappa_p^p(x, -)$ is simply defined by mapping point strata of $p^{-1}(x)$ monotonically to corresponding point strata of $\tilde{p}^{-1}(x)$ (where ‘corresponding’ refers to the identification provided by the truss isomorphism $\mathbb{P}_\top(p) = \mathbb{P}_\top(\tilde{p})$), and then extending the mapping linearly to the interval strata in between those point strata.

Next, if $\dim(r) > 0$, again define the fiber isomorphism $\kappa_p^p(x, -)$ to map point strata of $p^{-1}(x)$ monotonically to corresponding point strata of $\tilde{p}^{-1}(x)$. Interval strata s_x in $p^{-1}(x)$ are restrictions of regular strata s in (M, f) to the fiber $p^{-1}(x)$, and canonically correspond to interval strata \tilde{s}_x in $\tilde{p}^{-1}(x)$. Now we define $\kappa_p^p(x, -)$ via a collection of maps $s_x \rightarrow \tilde{s}_x$, each depending on the local structure around the regular stratum s .

- › For all x which do not lie in a catchment area C_b of some cell $b \subset \partial r$, define the required map $s_x \rightarrow \tilde{s}_x$ simply by linear interpolation.
- › Now proceed inductively in the increasing cell dimension $\dim(b)$ of the cell b for which x is in the catchment area C_b . When $x \in C_b$, the point x is of the form $(u, t) \in \bar{C}_b \cong F_b \times [0, 1)$ for $t \in (0, 1)$. When b is not in the regular contour of the regular stratum s , i.e. $b \notin \mathbf{c}_s$, we define $s_x \rightarrow \tilde{s}_x$ again by linear interpolation. When b is in the regular contour of the regular stratum s , i.e. $b \in \mathbf{c}_s$, more care is required and we define

$$\kappa_p^p(x, -) = (1 - t)\kappa_p^p((u, 0), -) + t\kappa_p^p(\pi_b(x), -)$$

where $\pi_b(x)$ is the catchment projection from [Construction 4.2.32](#). Both the isomorphisms κ_p^p used in that interpolation are already defined by the inductive assumption.

Observe that this induction exhaustively and continuously extends the definition of the bundle isomorphism κ_p^p to all fibers over the stratum r , as needed. —

PROOF OF PROPOSITION 4.2.26. The preceding construction provides the required isomorphism κ_p^p , when the 1-mesh bundles are closed. By [Observation 4.2.27](#), that implies the existence of such an isomorphism in the case of general 1-mesh bundles. □

PROOF OF PROPOSITION 4.2.22. By [Observations 4.2.24](#) and [4.2.25](#), the case of 1-mesh bundles over a cellular stratification implies the case of n -mesh bundles over a cellable stratification. □

4.2.3.4. ✱ Continuity of the construction. We make a few useful-later observations about the [Construction 4.2.35](#) of the mesh bundle isomorphisms κ_p^p .

Firstly, though evident, we record the fact that the bundle isomorphism only depends on the realized structure of the mesh bundles, as follows.

OBSERVATION 4.2.36 (The bundle isomorphism preserves strict identities). Consider 1-mesh bundles $p : (M, f) \rightarrow (B, g)$ and $\tilde{p} : (\tilde{M}, \tilde{f}) \rightarrow (B, g)$ with

a cellular base (B, g) and such that $\mathbb{T}(p) = \mathbb{T}(\tilde{p})$. Identify M and \tilde{M} as subspaces of $B \times \mathbb{R}$ using their 1-framed realizations $\gamma : M \hookrightarrow B \times \mathbb{R}$ and $\tilde{\gamma} : \tilde{M} \hookrightarrow B \times \mathbb{R}$. If (M, f) and (\tilde{M}, \tilde{f}) have identical realizations in $B \times \mathbb{R}$, then the inductive construction of $\kappa_{\tilde{p}}^p$ (in [Construction 4.2.35](#)) yields the bundle identity map $\text{id} : p = \tilde{p}$ on the bundle realizations. \square

Secondly, the construction of the mesh bundle isomorphism is continuous in families, as follows.

DEFINITION 4.2.37 (Families of 1-mesh bundles). Given a space Z , a **Z -family** of 1-mesh bundles over (B, g) is a 1-mesh bundle $p : (M, f) \rightarrow Z \times (B, g)$. For $z \in Z$, the **z -slice** of p , denoted $p_z : (M_z, f_z) \rightarrow (B, g)$, is the restriction of p to the subspace $B \cong \{z\} \times B \hookrightarrow Z \times B$. \square

OBSERVATION 4.2.38 (The mesh bundle isomorphism for families). For a cellular stratification (B, g) , consider Z -families of 1-mesh bundles $p : (M, f) \rightarrow Z \times (B, g)$ and $\tilde{p} : (\tilde{M}, \tilde{f}) \rightarrow Z \times (B, g)$, such that $\mathbb{T}(p) = \mathbb{T}(\tilde{p})$. Choose a catchment structure for (B, g) (see [Remark 4.2.34](#)). This choice provides a catchment structure for the bundles p_z and \tilde{p}_z for all $z \in Z$, and we may thus construct the 1-mesh bundle isomorphisms $\kappa_{\tilde{p}_z}^{p_z} : p_z \cong \tilde{p}_z$, using [Construction 4.2.35](#). The fiberwise bundle isomorphisms $\kappa_{\tilde{p}_z}^{p_z}$ immediately assemble into a single continuous bundle isomorphism $\kappa_{\tilde{p}}^p : p \cong \tilde{p}$. \square

Finally, we mention a means of constructing Z -families of 1-mesh bundles, namely by pullback along Z -families of stratified maps.

REMARK 4.2.39 (Families of bundles from pullback along families of maps). Consider cellular stratifications (B, g) and (B, \tilde{g}) , and let $F : Z \rightarrow \text{Strat}_{\text{lf}}(g, \tilde{g})$ be a continuous map from a space Z to the space of stratified maps between g and \tilde{g} , such that F is constant on entrance path posets (that is, $\mathbb{T} \circ F : Z \rightarrow \mathcal{P}\text{os}_{\text{lf}}(\mathbb{T}g, \mathbb{T}\tilde{g})$ is constant). By the tensoredness of stratified spaces (see [Construction B.2.23](#)), we can consider F as a stratified map $F : Z \times g \rightarrow \tilde{g}$. Given a 1-mesh bundle $\tilde{p} : (\tilde{M}, \tilde{f}) \rightarrow (B, \tilde{g})$, we can therefore construct a Z -family of 1-mesh bundles as the pullback $F^*\tilde{p}$ of \tilde{p} along $F : Z \times g \rightarrow \tilde{g}$ (see [Construction 4.1.57](#)). \square

4.2.4. Weak faithfulness of the fundamental truss functor. We now show that the fundamental truss functor \mathbb{T} is a *weakly faithful* functor of ∞ -categories.

As usual, for $m \in \mathbb{N}$, denote by D^{m+1} the closed $(m + 1)$ -ball and by S^m its boundary. Recall that a topological space U is weakly contractible if every map $\zeta : S^m \rightarrow U$ has an extension to a map $\theta : D^{m+1} \rightarrow U$ (we will refer to such an extension θ as a ‘filler’ for ζ).

PROPOSITION 4.2.40 (Weak faithfulness, closed case). *Given closed n -mesh bundles p and p' , with cellable base (B, g) , the fundamental truss functor hom-space map*

$$\mathbb{T} : \bar{\text{Mesh}}_n(B, g)(p, p') \rightarrow \bar{\text{Tr}}_n(\mathbb{T}g)(\mathbb{T}(p), \mathbb{T}(p'))$$

has empty or weakly contractible preimages.

REMARK 4.2.41 (Weak faithfulness in other rigid cases). Though we will give the explicit statement and proof of weak faithfulness only in the case of closed n -mesh bundles, note that the following cases are immediate analogs of our proof:

- › The case of open n -mesh bundles and regular maps ($\mathring{Mesh}_n(B, g)$)
- › The case of general n -mesh bundles and balanced maps ($Mesh_n^{\text{bal}}(B, g)$)
- › The case of n -meshes and their degeneracies ($Mesh_n^{\text{deg}}$)
- › The case of n -meshes and their coarsenings ($Mesh_n^{\text{crs}}$)

The thread that ties these different cases together are the rigidity results of Lemma 2.3.72. —

The proof of Proposition 4.2.40 will occupy the whole of this subsection.

REMARK 4.2.42 (The fundamental truss functor is weakly fully faithful). Once we have constructed the weak inverse of the fundamental truss functor \mathbb{P}_\top , it will follow that the fibers of the hom-space maps of \mathbb{P}_\top are, in fact, never empty. —

SYNOPSIS. We observe that it suffices to prove weak faithfulness of the fundamental truss functor for bundles over cellular bases. We then reduce weak faithfulness for n -mesh bundles to a filler lifting condition for 1-mesh bundles. Finally, we prove that lifting condition by explicitly constructing a filler via suitable fiberwise convex combinations of mesh maps.

★ Proof of weak faithfulness. We first observe that it suffices to prove weak faithfulness for a cellular base.

REMARK 4.2.43 (Reduction to cellular base, for weak faithfulness). Given closed n -mesh bundles p and p' as in Proposition 4.2.40, fix a refinement $G : (B, c) \rightarrow (B, g)$ of the cellable stratification (B, g) by a cellular stratification (B, c) . Using Construction 4.1.93, we may pullback both p and p' to n -mesh bundles G^*p and G^*p' over (B, c) . Let $F : \mathbb{P}_\top(p) \rightarrow \mathbb{P}_\top(p')$ be a map of the fundamental n -truss bundles. This map pulls back, along $\mathbb{P}G : \mathbb{P}c \rightarrow \mathbb{P}g$, to an n -truss bundle map $(\mathbb{P}G)^*F : (\mathbb{P}G)^*\mathbb{P}_\top(p) \rightarrow (\mathbb{P}G)^*\mathbb{P}_\top(p')$ (see Construction 2.3.54). The fiber of \mathbb{P}_\top in $\mathring{Mesh}_n(B, c)(G^*p, G^*p')$ over $(\mathbb{P}G)^*F$ is homeomorphic to the fiber of \mathbb{P}_\top in $\mathring{Mesh}_n(B, g)(p, p')$ over F . Thus it is sufficient to prove Proposition 4.2.40 in the case of a cellular base. —

We next tackle the proof of Proposition 4.2.40 for a cellular base (B, g) . Let p and p' be closed n -mesh bundles consisting of 1-mesh bundles $p_i : (M_i, f_i) \rightarrow (M_{i-1}, f_{i-1})$ and $p'_i : (M'_i, f'_i) \rightarrow (M'_{i-1}, f'_{i-1})$, respectively, with $(M_0, f_0) = (B, g) = (M'_0, f'_0)$. Consider a map $\zeta : S^m \rightarrow \mathring{Mesh}_n(B, g)(p, p')$ such that $\mathbb{P}_\top(\zeta)$ is constant (in other words, ζ maps into a single fiber of \mathbb{P}_\top). Note that, by rigidity of singular truss maps of closed trusses (see Lemma 2.3.72), this constancy condition is satisfied automatically except when $m = 0$.

Recall that truncation of meshes is an ∞ -functor (see Remark 4.1.98). Truncating the map ζ to degrees below n , we obtain the map $\beta := \zeta_{<n} : S^m \rightarrow \tilde{\mathcal{M}}esh_{n-1}(B, g)(p_{<n}, p'_{<n})$. Arguing by induction, we may assume that β has a filler $\eta : D^{m+1} \rightarrow \tilde{\mathcal{M}}esh_{n-1}(B, g)(p_{<n}, p'_{<n})$. Using the tensoredness of stratified spaces (see Construction B.2.23), we may consider the map ζ as a stratified map $S^m \times f_n \rightarrow f'_n$, the map β as a stratified map $S^m \times f_{n-1} \rightarrow f'_{n-1}$, and the map η as a stratified map $D^{m+1} \times f_{n-1} \rightarrow f'_{n-1}$. To show that ζ has a filler it will therefore be sufficient to prove the following.

PROPOSITION 4.2.44 (Lifting fillers in closed 1-mesh bundles). *Consider closed 1-mesh bundles $p : (M, f) \rightarrow (B, g)$ and $\tilde{p} : (\tilde{M}, \tilde{f}) \rightarrow (\tilde{B}, \tilde{g})$, with cellular bases, and maps $\zeta : S^m \times f \rightarrow \tilde{f}$ and $\beta : S^m \times g \rightarrow \tilde{g}$ such that, for each $e \in S^m$, the restriction $(\zeta(e, -), \beta(e, -)) : p \rightarrow \tilde{p}$ is a 1-mesh bundle map. (If $m = 0$, further assume $\mathbb{1}_{\top}(\zeta(e, -), \beta(e, -))$ is independent of $e \in S^0$).*

Then any filler $\eta : D^{m+1} \times g \rightarrow \tilde{g}$ of β lifts to a filler $\theta : D^{m+1} \times f \rightarrow \tilde{f}$ of ζ such that, for each $e \in D^{m+1}$, the restriction $(\theta(e, -), \eta(e, -)) : p \rightarrow \tilde{p}$ is a 1-mesh bundle map.

PROOF. It will be convenient to consider D^{m+1} as the quotient of $[0, 1] \times S^m$ by the subset $\{1\} \times S^m$. As such, we will construct the required filler θ as a mapping $[0, 1] \times S^m \times f \rightarrow \tilde{f}$, such that $\theta(1, -)$ is constant in the S^m component. To construct the required filler θ of ζ , lifting the filler η of β , we proceed in two steps.

First, by pulling back along the base filler η , we will construct a ‘homotopy #1’ map $\theta_1 : [0, 1] \times S^m \times f \rightarrow \tilde{f}$, which homotopes $\theta_1(0, -) = \zeta$ into a map $\theta_1(1, -) : S^m \times f \rightarrow \tilde{f}$ that descends to a map of base stratifications $S^m \times g \rightarrow \tilde{g}$ that is constant in the first component S^m .

Second, using ‘fiberwise contractions’, we will construct a ‘homotopy #2’ map $\theta_2 : [0, 1] \times S^m \times f \rightarrow \tilde{f}$, which homotopes $\theta_2(0, -) = \theta_1(1, -)$ into a map $\theta_2(1, -) : S^m \times f \rightarrow \tilde{f}$ that is itself constant in the first component S^m . Concatenating the homotopies θ_1 and θ_2 will provide the required filler θ of ζ .

(1) Define a closed 1-mesh bundle $\beta^*\tilde{p}$ by pulling back \tilde{p} along β and define a map $\hat{\zeta}$ as the factorization of ζ through this pullback as shown below.

$$\begin{array}{ccccc}
 & & \zeta & & \\
 & & \curvearrowright & & \\
 S^m \times f & \xrightarrow{\quad \hat{\zeta} \quad} & \beta^* \tilde{f} & \xrightarrow{\quad \quad} & \tilde{f} \\
 S^m \times p \downarrow & & \beta^* \tilde{p} \downarrow & \lrcorner & \downarrow \tilde{p} \\
 S^m \times g & \xlongequal{\quad \text{id} \quad} & S^m \times g & \xrightarrow{\quad \beta \quad} & \tilde{g}
 \end{array}$$

Note $\beta^*\tilde{p}$ is an S^m -family of closed 1-mesh bundles over g (see Remark 4.2.39). We may modify this into a $([0, 1] \times S^m)$ -family by simply taking the product $[0, 1] \times -$. The resulting closed 1-mesh bundle $[0, 1] \times \beta^*\tilde{p}$ is bundle isomorphic

to the closed 1-mesh bundle $\eta^*\tilde{p}$ defined by the pullback on the right below.

$$\begin{array}{ccccc} [0, 1] \times \beta^*\tilde{f} & \xrightarrow{\sim \kappa} & \eta^*\tilde{f} & \longrightarrow & \tilde{f} \\ [0,1] \times \beta^*\tilde{p} \downarrow & & \eta^*\tilde{p} \downarrow & \lrcorner & \downarrow \tilde{p} \\ [0, 1] \times S^m \times g & \xrightarrow{\text{id}} & [0, 1] \times S^m \times g & \xrightarrow{\eta} & \tilde{g} \end{array}$$

Here, the isomorphism κ can be constructed using [Observation 4.2.38](#), since g is assumed to be cellular. The homotopy #1 map $\theta_1 : [0, 1] \times S^m \times f \rightarrow \tilde{f}$ is now defined as the composite

$$[0, 1] \times S^m \times f \xrightarrow{[0,1] \times \hat{\zeta}} [0, 1] \times \beta^*\tilde{f} \xrightarrow{\kappa} \eta^*\tilde{f} \rightarrow \tilde{f} .$$

Since the κ construction preserves identities (see [Observation 4.2.36](#)) and since $\beta = \eta(0, -)$, we find that $\kappa(0, -)$ is the identity on $\beta^*\tilde{f}$. Thus, homotopy #1 satisfies $\theta_1(0, -) = \zeta$, and lifts η in the sense that

$$\begin{array}{ccc} [0, 1] \times S^m \times f & \xrightarrow{\theta_1} & \tilde{f} \\ [0,1] \times S^m \times p \downarrow & & \downarrow \tilde{p} \\ [0, 1] \times S^m \times g & \xrightarrow{\eta} & \tilde{g} \end{array}$$

This completes the first half of the construction of θ .

(2) It remains to construct the homotopy #2 map $\theta_2 : [0, 1] \times S^m \times f \rightarrow \tilde{f}$ such that $\theta_2(0, -) = \theta_1(1, -)$. Recall that for a stratification (Y, h) and a subspace $X \subset Y$, we will use (X, h) to denote the restricted stratification (see [Definition B.2.7](#)). We may define the homotopy θ_2 by convexly combining fiberwise maps $\theta_1(1, e, -) : (p^{-1}(y), f) \rightarrow (\tilde{p}^{-1}\eta(1, e, y), \tilde{f})$, for $e \in S^m$ and $y \in B$ (note that $\eta(1, e, y)$ is in fact independent of $e \in S^m$). Specifically, pick any $e_0 \in S^m$, and for $t \in [0, 1]$, $e \in S^m$, and $y \in B$, define the restriction of $\theta_2(t, e, -)$ to the fiber over y to be the map

$$\begin{aligned} \theta_2(t, e, -) : (p^{-1}(y), f) &\rightarrow (\tilde{p}^{-1}\eta(1, e, y), \tilde{f}) \\ x &\mapsto (1-t) \cdot \theta_1(1, e, x) + t \cdot \theta_1(1, e_0, x) \end{aligned}$$

Note that $\theta_2(t, e, -)$ is indeed a 1-mesh map for all t and e , because $\mathbb{P}_{\mathbb{T}}(\theta_1(1, e, -)) = \mathbb{P}_{\mathbb{T}}(\theta_1(1, e_0, -))$, i.e. the convexly combined factors induce the same maps on 1-trusses (that in turn is the case since, by assumption, $\mathbb{P}_{\mathbb{T}}(\zeta(e, -), \beta(e, -))$ is independent of $e \in S^m$). Note that at $t = 1$, the map $\theta_2(t, e, -)$ becomes independent of $e \in S^m$. We can finally chain the homotopies θ_1 and θ_2 into a single homotopy

$$\theta := \theta_1 * \theta_2 : [0, 1] \times S^m \times f \rightarrow \tilde{f}$$

which defines the filler θ of ζ , lifting the filler η of β , as required. \square

PROOF OF PROPOSITION 4.2.40. By [Remark 4.2.43](#), it suffices to address the case of cellular base. The discussion preceding the statement of [Proposition 4.2.44](#) shows that the desired weak faithfulness for closed n -mesh

bundles follows inductively from the lifting property of closed 1-mesh bundles established in that proposition. \square

4.2.5. Mesh realizations. We will now construct the mesh realization functors from various categories of n -trusses to corresponding categories of n -meshes.³⁵ In the first and most foundational instance, we will have the mesh realization functor

$$\|-\|_{\mathbb{M}} : \mathbf{Trs}_n \rightarrow \mathbf{Mesh}_n$$

Note that this functor is necessarily an ∞ -functor because the hom-spaces of its domain have discrete topology. More generally, for a fixed cellulable base stratification (B, g) , we will have the mesh bundle realization functor

$$\|-\|_{\mathbb{M}} : \mathbf{Trs}_n(\mathbb{P}g) \rightarrow \mathbf{Mesh}_n(B, g)$$

Restricted to the subcategories of closed or open trusses and meshes, this functor provides weak inverses to the corresponding previously constructed fundamental truss functors. However, the construction of mesh realization will not provide an enriched functor $\mathcal{T}rs_n(\mathbb{P}g) \dashrightarrow \mathbf{Mesh}_n(B, g)$, and so no candidate inverse, in any case, for the enriched fundamental truss functor $\mathbf{Mesh}_n(B, g) \rightarrow \mathcal{T}rs_n(\mathbb{P}g)$.

The simplest and most direct construction of mesh realizations occurs for closed trusses; in this case, we will obtain the mesh realization $\|-\|_{\mathbb{M}}$ by a direct application of the stratified realization $\|-\|$. For non-closed trusses, the stratified realization does not always produce the correct mesh topological type; that difficulty arises essentially because the ordinary geometric realization cannot tell the difference between the point poset of a trivial closed 1-truss (which ought to realize to a trivial closed 1-mesh, i.e. a point) and the point poset of a trivial open 1-truss (which ought to realize to a trivial open 1-mesh, i.e. an open interval). We will construct mesh realizations for general trusses by taking the not-necessarily-closed truss, compactifying it to a closed truss, forming the mesh realization, and then extracting the appropriate submesh as a constructible substratification.

SYNOPSIS. We define mesh realizations for closed trusses via the stratified realization. We then construct the mesh realization for a general truss as a constructible substratification of the realization of the cubical compactification of the truss. We build the required cubical compactification by adjoining singular endpoints fiberwise and inductively throughout the truss tower. We then construct the realization of truss bundles using a compactified cellulation of the base stratification. Finally, we formulate a distinct realization for truss coarsenings, which is, unlike the usual mesh realization, a mesh coarsening.

³⁵In fact, aside from the case of closed trusses, the mesh realization will be only semifunctorial; we elide the ‘semi’ as immaterial.

CLD did not check the above long proof.
2 : Will recheck one last time

4.2.5.1. Realizations of closed trusses. We construct mesh realizations of closed trusses using the ordinary stratified geometric realization. We first address the case of 1-truss bundles; the case of n -trusses will follow immediately by iteration. Recall the stratified realizations of posets and poset maps from [Constructions 1.3.4](#) and [1.3.5](#).

CONSTRUCTION 4.2.45 (1-Mesh bundle realizations of closed 1-truss bundles). Given a closed 1-truss bundle $p : T \rightarrow X$, we will endow the realized stratified map $\|p\| : \|T\| \rightarrow \|X\|$ with the structure of a closed 1-mesh bundle; we refer to the result as the ‘closed 1-mesh bundle realization’ and denote it $\|p\|_{\mathbb{M}} : \|T\| \rightarrow \|X\|$.

We construct a 1-framed realization $\gamma : |T| \hookrightarrow |X| \times \mathbb{R}$ for $\|p\|$. Define γ to map 0-simplices of $|T|$ such that fibers of p land in the corresponding fibers of $|X| \times \mathbb{R} \rightarrow |X|$ in a frame-order-preserving manner (e.g., mapping the 0-simplex $i \in p^{-1}(x)$ to $(x, i) \in |X| \times \mathbb{N} \hookrightarrow |X| \times \mathbb{R}$). Then extend the mapping linearly to the remaining simplices of the realization $|T|$.

To see that this defines the data of a 1-mesh bundle, one checks using an induction on the scaffold order of simplices (see [Section 2.2.2](#)) that γ is an embedding with continuous upper and lower realization bounds. Constructibility of the family of meshes follows directly from the singular functionality of the constituent truss bordisms of the given truss bundle. —

EXAMPLE 4.2.46 (1-Mesh bundle realizations of 1-truss bundles). In [Figure 4.21](#) we depict on the left a closed 1-truss bundle $p : T \rightarrow X$ (note that we only depict generating arrows, see [Construction 2.1.81](#)), and on the right its closed 1-mesh bundle realization $\|p\|_{\mathbb{M}} : \|T\| \rightarrow \|X\|$, shown via the 1-framed realization $\gamma : |T| \hookrightarrow |X| \times \mathbb{R}$. —

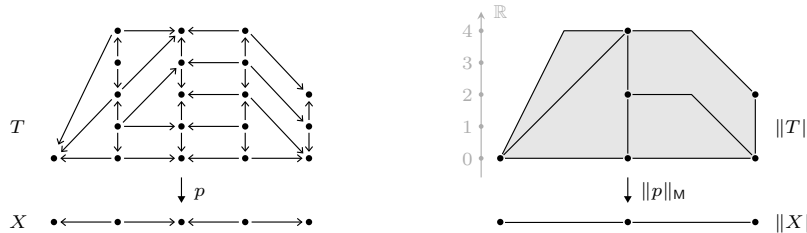

FIGURE 4.21. 1-Mesh bundle realization of a 1-truss bundle.

CONSTRUCTION 4.2.47 (Mesh realizations of closed n -trusses). For a closed n -truss T , consisting of 1-truss bundles $p_i : T_i \rightarrow T_{i-1}$, the ‘closed n -mesh realization’ $\|T\|_{\mathbb{M}}$ is the closed n -mesh defined by the tower of 1-mesh bundles

$$\|T_n\| \xrightarrow{\|p_n\|_{\mathbb{M}}} \|T_{n-1}\| \xrightarrow{\|p_{n-1}\|_{\mathbb{M}}} \dots \xrightarrow{\|p_2\|_{\mathbb{M}}} \|T_1\| \xrightarrow{\|p_1\|_{\mathbb{M}}} \|T_0\|$$

where each $\|p_i\|_{\mathbb{M}}$ is the 1-mesh bundle realization of the 1-truss bundle p_i , given by [Construction 4.2.45](#). —

CONSTRUCTION 4.2.48 (Mesh map realizations of maps of closed n -trusses). Given closed n -trusses T and S , and any n -truss map $F : T \rightarrow S$, consisting of the tower of poset maps $F_i : T_i \rightarrow S_i$, the ‘closed n -mesh map realization’ $\|F\|_{\mathbf{M}}$ is the map of closed n -meshes consisting of the tower of stratified realizations $\|F_i\| : \|T_i\| \rightarrow \|S_i\|$. $\text{—}\lrcorner$

We typically denote the tower $\{\|F_i\|\}$ of stratified realizations by simply $\|F\|$; this is (for maps of closed n -trusses) the same tower as the mesh map realization $\|F\|_{\mathbf{M}}$, but considered merely as a sequence of stratified bundles rather than a sequence of mesh bundles.

As in general the stratifications of the base space will warrant more careful attention, we will return to the case of n -truss bundles in due course.

4.2.5.2. Realizations of general trusses and maps. We turn to the construction of mesh realizations for general n -trusses, and also realizations of maps thereof. This case requires more care because, as mentioned earlier, the naive geometric realization of posets (taking their nerve and applying the usual geometric realization of simplicial sets) inappropriately degenerates trivial open 1-truss fibers. The construction of mesh realizations will proceed by taking a general truss, compactifying it to a closed truss, realizing that to a closed mesh, and finally taking a suitable submesh.

Fiberwise compactifications of 1-truss bundles are a combinatorial analog of the fiberwise compactifications of 1-mesh bundles given in Construction 4.1.58. However, when applying fiberwise compactifications inductively to a tower of bundles, there remains at each stage a choice of how to extend a bundle to the compactification of its base. There are several reasonable possibilities for such extensions; we make a particular choice, the ‘cubical compactification’, which is suitably *initial* among retractible compactifications, and which will admit a useful explicit construction. We describe these compactifications in the general context of truss bundles.

DEFINITION 4.2.49 (Retractable compactifications). For an n -truss bundle p , a **retractable compactification** is a closed n -truss bundle q , together with a pair of base-preserving bundle maps

$$\iota : p \xrightarrow{\simeq} q : \rho$$

where the map ι is balanced, the composite $\rho \circ \iota$ is the identity id_p , and the composite $\iota \circ \rho$ admits a natural transformation to the identity id_q . $\text{—}\lrcorner$

DEFINITION 4.2.50 (Cubical compactification, universal property). For an n -truss bundle p over a poset X , the **cubical compactification** is the unique retractable compactification

$$\text{ci} : p \xrightarrow{\simeq} \bar{p} : \text{cr} \quad ,$$

consisting of the ‘cubical inclusion’ ci and the ‘cubical retraction’ cr , such that, for any other retractable compactification $\iota : p \xrightarrow{\simeq} q : \rho$ there exists a unique n -truss bundle r over $X \times [1]$ subject to the following conditions:

- (1) $r|_{X \times \{0\}} = \bar{p}$ and $r|_{X \times \{1\}} = q$;
- (2) the restriction of the bundle r , to the union of the images of the inclusions ci in \bar{p} and ι in q , is the product bundle $p \times [1]$ over $X \times [1]$. —

EXAMPLE 4.2.51 (Cubical compactification). In Figure 4.22, we depict the inclusion $\text{ci} : T \hookrightarrow \bar{T}$ of an open 2-truss T (in black) into its cubical compactification \bar{T} (extending T by the gray structure). —

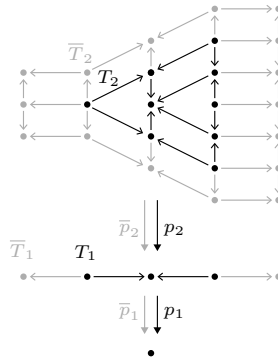

FIGURE 4.22. Cubical compactification of an open 2-truss.

We defer the explicit construction of cubical compactifications, and first complete the construction of mesh realizations for general n -trusses. Recall that a constructible substratification (see Definition B.2.8) is determined by its fundamental poset mapping.

CONSTRUCTION 4.2.52 (Mesh realizations of general n -trusses). For an n -truss T , the n -**mesh realization** $\|T\|_{\mathbf{M}}$ is the constructible submesh

$$\|\text{ci}\|_{\mathbf{M}} : \|T\|_{\mathbf{M}} \hookrightarrow \|\bar{T}\|_{\mathbf{M}}$$

whose fundamental poset subtruss is

$$\sqcap_T(\|\text{ci}\|_{\mathbf{M}}) = \text{ci} : T \hookrightarrow \bar{T}$$

That is, the mesh realization $\|T\|_{\mathbf{M}}$ is the submesh of the closed n -mesh $\|\bar{T}\|_{\mathbf{M}}$, whose stages are the constructible substratifications $(\|\text{ci}\|_{\mathbf{M}})_i : (\|T\|_{\mathbf{M}})_i \hookrightarrow (\|\bar{T}\|_{\mathbf{M}})_i$ that have fundamental poset maps $\sqcap((\|\text{ci}\|_{\mathbf{M}})_i)$ being the i -th stages $\text{ci}_i : T_i \hookrightarrow \bar{T}_i$ of the cubical compactification inclusion map ci . —

The fact that the mesh realization $\|T\|_{\mathbf{M}}$ indeed forms an n -mesh follows from the later explicit inductive construction of cubical compactifications. Note that when the truss T is closed, the preceding construction of $\|T\|_{\mathbf{M}}$ specializes to the earlier Construction 4.2.47.

NOTATION 4.2.53 (Abbreviation for mesh realization stages). For an n -truss T , just to have a slightly more concise notation, we will denote the i -th stage $(\|T\|_{\mathbf{M}})_i$ of the mesh realization $\|T\|_{\mathbf{M}}$ by simply $\|T_i\|_{\mathbf{M}}$. Though

the poset T_i does not by itself have a mesh realization $\|-\|_{\mathbf{M}}$, one should think of taking the mesh realization of that stage in the ambient context of the whole truss. Similarly, we will denote the i -th stage $(\|ci\|_{\mathbf{M}})_i$ of the compactification inclusion by simply $\|ci_i\|_{\mathbf{M}}$. \square

EXAMPLE 4.2.54 (Mesh realization). Recall the open 2-truss T from Figure 4.22. In Figure 4.23, we depict the closed mesh realization $\|\bar{T}\|_{\mathbf{M}}$ of the cubical compactification \bar{T} , together with the resulting open mesh realization $\|T\|_{\mathbf{M}}$ of the open truss T , as a tower of constructible substratifications. \square

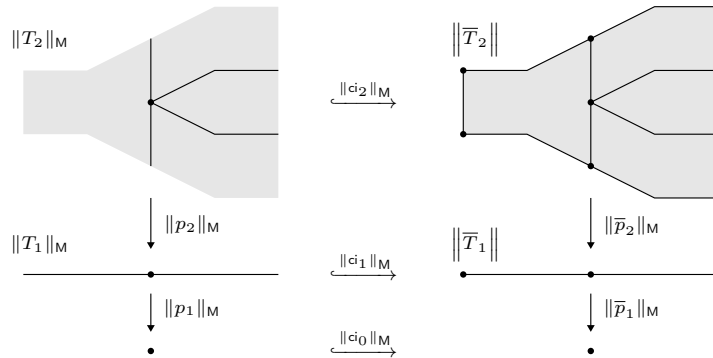
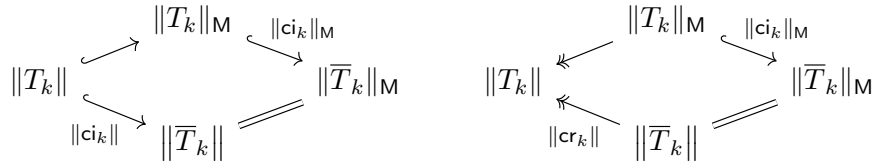

FIGURE 4.23. The mesh realization of an open 2-truss.

REMARK 4.2.55 (Stratified realizations versus mesh realizations). For a non-closed n -truss T , the stratified realization $\|T_k\|$ (of the k -stage poset) and the mesh realization $\|T_k\|_{\mathbf{M}} \equiv (\|T\|_{\mathbf{M}})_k$ are, in general, distinct stratifications. Nevertheless, the stratified realization includes into the mesh realization, and the mesh realization retracts to the stratified realization, as follows.

To describe the inclusion and retraction between the stratified realization $\|T_k\|$ and the mesh realization $\|T_k\|_{\mathbf{M}}$, we must consider the realization of the compactification $\|\bar{T}_k\| = \|\bar{T}_k\|_{\mathbf{M}}$; of course for the compactification, the stratified and mesh realizations agree. The stratified-to-mesh inclusion $\|T_k\| \hookrightarrow \|T_k\|_{\mathbf{M}}$ and mesh-to-stratified retraction $\|T_k\|_{\mathbf{M}} \twoheadrightarrow \|T_k\|$ are defined by the following squares:



That is, the stratified-to-mesh inclusion $\|T_k\| \hookrightarrow \|T_k\|_{\mathbf{M}}$ is the factorization of the stratified inclusion $\|ci_k\|$ through the constructible substratification $\|ci_k\|_{\mathbf{M}}$; and the mesh-to-stratified retraction $\|T_k\|_{\mathbf{M}} \twoheadrightarrow \|T_k\|$ is the composite of the constructible substratification $\|ci_k\|_{\mathbf{M}}$ with the stratified retraction $\|cr_k\|$. \square

It remains to define mesh realizations for n -truss maps. The realization of general n -trusses in [Construction 4.2.52](#) was defined as a constructible submesh of the mesh realization of the cubical compactification (which latter realization was given by an ordinary stratified realization). One would expect the realization of general n -truss maps to also be defined via cubical compactifications; however, cubical compactification is *not* naively functorial and so this approach requires some care, as follows.

CONSTRUCTION 4.2.56 (Cubical compactification for truss bundle maps). Let p and q be n -truss bundles over the posets X and Y respectively, and let $F : p \rightarrow q$ be a truss bundle map. Set the cubical compactification of the truss bundle map F to be the truss bundle map \bar{F} defined as the composite

$$\bar{p} \xrightarrow{\text{cr}} p \xrightarrow{F} q \xrightarrow{\text{ci}} \bar{q} \quad \text{—}$$

REMARK 4.2.57 (Semifunctoriality of cubical compactification). Though cubical compactification, as given for objects in [Definition 4.2.50](#) and for morphisms in [Construction 4.2.56](#), does not preserve identities and so is not a functor, per se, it does preserve composition of maps, and so is in that sense a semifunctor. —

CONVENTION 4.2.58 (Semifunctors referred to as functors). In a rather pointed abuse of terminology, we will paper over the aforementioned fact that compactification does not preserve identities, and will willfully use the term ‘functor’ to refer to semifunctors, particularly for the mesh realization functors constructed using compactification. —

CONSTRUCTION 4.2.59 (Mesh map realizations of truss maps). For an n -truss map $F : T \rightarrow S$, the **n -mesh map realization** $\|F\|_{\mathbb{M}} : \|T\|_{\mathbb{M}} \rightarrow \|S\|_{\mathbb{M}}$ is the lift of the closed n -mesh map realization $\|\bar{F}\|_{\mathbb{M}} : \|\bar{T}\|_{\mathbb{M}} \rightarrow \|\bar{S}\|_{\mathbb{M}}$ (see [Construction 4.2.48](#)) of the cubical compactification $\bar{F} : \bar{T} \rightarrow \bar{S}$ (see [Construction 4.2.56](#)), along the defining constructible substratifications $\|T\|_{\mathbb{M}} \hookrightarrow \|\bar{T}\|_{\mathbb{M}}$ and $\|S\|_{\mathbb{M}} \hookrightarrow \|\bar{S}\|_{\mathbb{M}}$, i.e. according to the following diagram:

$$\begin{array}{ccc} \|T\|_{\mathbb{M}} & \xrightarrow{\|F\|_{\mathbb{M}}} & \|S\|_{\mathbb{M}} \\ \|\text{ci}\|_{\mathbb{M}} \downarrow & & \downarrow \|\text{ci}\|_{\mathbb{M}} \\ \|\bar{T}\|_{\mathbb{M}} & \xrightarrow{\|\bar{F}\|_{\mathbb{M}}} & \|\bar{S}\|_{\mathbb{M}} \quad . \end{array} \quad \text{—}$$

Note that this construction is given just for realizations of truss maps, not truss bundle maps. For bundles (and their maps), the stratified realization of a base fundamental poset (or poset map) need not faithfully encode a base stratification (or map thereof); we address the generalization to bundles later.

Now observe that the association $F \mapsto \|F\|_{\mathbb{M}}$ from a truss map to its mesh map realization is (semi)functorial; note [Convention 4.2.58](#).

NOTATION 4.2.60 (Mesh realization functor). Constructions 4.2.52 and 4.2.59 together yield the n -**mesh realization functor**

$$\|-\|_{\mathbb{M}} : \mathbf{Trs}_n \rightarrow \mathbf{Mesh}_n$$

from n -trusses to n -meshes. —

Note that whenever a truss map is singular or regular, its mesh map realization is singular or regular, respectively. Thus in particular the mesh realization functor restricts to a functor from closed trusses with singular maps to closed meshes with singular maps, and restricts to a functor from open trusses with regular maps to open meshes with regular maps.

OBSERVATION 4.2.61 (Failure of topological enrichment for mesh realization). The preceding construction of mesh realizations does not define an enriched functor $\|-\|_{\mathbb{M}} : \mathcal{T}r_s_n \rightarrow \mathcal{M}esh_n$; the difficulty is already visible in the discontinuity of the stratified realization functor on posets (see Remark B.2.21). —

OBSERVATION 4.2.62 (Mesh realization is right inverse to the fundamental truss). Note that, after restricting either to closed meshes and trusses and their singular maps, or to open meshes and trusses and their regular maps, the mesh realization of Notation 4.2.60 is right inverse to the fundamental truss functor of Corollary 4.2.20, in the sense that there is unique natural isomorphism $\mathbb{I}_{\mathbb{T}} \circ \|-\|_{\mathbb{M}} \cong \text{id}$.

Of course, forgetting the enrichment of the target of the functor in Notation 4.2.60 provides a realization $\|-\|_{\mathbb{M}} : \mathbf{Trs}_n \rightarrow \mathbf{Mesh}_n$, which is, without restriction, right inverse to the fundamental truss functor $\mathbb{I}_{\mathbb{T}} : \mathbf{Mesh}_n \rightarrow \mathbf{Trs}_n$. —

4.2.5.3. * Constructing cubical compactifications. We now provide the deferred construction of cubical compactifications, first for 1-trusses, then for 1-truss bundles, and finally for n -truss bundles.

CONSTRUCTION 4.2.63 (Cubical compactification of 1-trusses). For a 1-truss T , its cubical compactification 1-truss \overline{T} (in the sense of Definition 4.2.50, and leaving the inclusion and retraction implicit) is obtained from the 1-truss T by adjoining a new upper, and respectively lower, singular endpoint if the upper, respectively lower, endpoint of the given 1-truss T is regular. —

CONSTRUCTION 4.2.64 (Cubical compactification of 1-truss bundles). For a 1-truss bundle $p : T \rightarrow X$, its cubical compactification 1-truss bundle $\overline{p} : \overline{T} \rightarrow X$ (in the sense of Definition 4.2.50) is obtained from the bundle p by compactifying each fiber of the bundle according to Construction 4.2.63, and extending the 1-truss bordisms to the compactified fibers in the unique endpoint-preserving way. —

CONSTRUCTION 4.2.65 (Cubical compactification of n -truss bundles). Let p be an n -truss bundle over a poset X , consisting of 1-truss bundle maps $p_i : T_i \rightarrow T_{i-1}$. Suppose by induction we have constructed the cubical

compactification $\text{ci} : p_{<n} \xrightarrow{\simeq} \bar{p}_{<n} : \text{cr}$ of the $(n-1)$ -truncated bundle $p_{<n}$. (The starting case is given by [Construction 4.2.64](#).)

Pull back the top bundle $p_n : T_n \rightarrow T_{n-1}$ along the retraction $\text{cr}_{n-1} : \bar{T}_{n-1} \rightarrow T_{n-1}$ to obtain the 1-truss bundle $\text{cr}_{n-1}^* p_n$ over the truncated compactification \bar{T}_{n-1} . Pulling back again along ci_{n-1} of course recovers the original bundle p_n , i.e. $\text{ci}_{n-1}^* \text{cr}_{n-1}^* p_n = p_n$. Thus we have a 1-truss subbundle map $\text{Tot}(\text{ci}_{n-1}) : p_n \hookrightarrow \text{cr}_{n-1}^* p_n$ and a 1-truss bundle map $\text{Tot}(\text{cr}_{n-1}) : \text{cr}_{n-1}^* p_n \rightarrow p_n$; these maps form an inclusion-retraction pair of bundles $p_n \xrightarrow{\simeq} \text{cr}_{n-1}^* p_n$. Applying [Construction 4.2.64](#) to the bundle $\text{cr}_{n-1}^* p_n$ provides the fiberwise compactification inclusion-retraction pair $\text{cr}_{n-1}^* p_n \xrightarrow{\simeq} \overline{\text{cr}_{n-1}^* p_n}$. Now set $\bar{p}_n := \overline{\text{cr}_{n-1}^* p_n}$ as the top bundle of the desired cubical compactification, and compose the two given inclusion-retraction pairs to obtain the pair $\text{ci}_n : p_n \xrightarrow{\simeq} \bar{p}_n : \text{cr}_n$. Altogether, the cubical compactification \bar{p} is the n -truss bundle obtained by augmenting the truncation $\bar{p}_{<n}$ with the bundle \bar{p}_n , along with the resulting inclusion-retraction pair $\text{ci} : p \xrightarrow{\simeq} \bar{p} : \text{cr}$, as required. \square

REMARK 4.2.66 (Universal property of cubical compactifications). That the previous construction satisfies the universal property indicated in [Definition 4.2.50](#) can be seen inductively as follows. Let $\text{ci} : p \xrightarrow{\simeq} \bar{p} : \text{cr}$ be the cubical compactification from [Construction 4.2.65](#), and consider another retractable compactification $\iota : p \xrightarrow{\simeq} q : \rho$. Inductively assume we have constructed the $(n-1)$ -truncation $r_{<n}$ of the desired ‘factorizing bundle’ r over $X \times [1]$.

As an inductive invariant, assume that whenever there is a relation $(0, x) \rightarrow (1, y)$ in the total poset of the $(n-1)$ -truss bundle $r_{<n}$, then there is a relation $\text{cr}_{n-1}(x) \rightarrow \rho_{n-1}(y)$ in the total poset of $p_{<n}$. From this, construct the full n -truss bundle r by augmenting $r_{<n}$ with the 1-truss bundle r_n , defined by

$$r_n|_{(0,x) \rightarrow (1,y)} := q_n|_{\iota_{n-1}(\rho_{n-1}(y)) \rightarrow y} \circ \bar{p}_n|_{\text{cr}_{n-1}(x) \rightarrow \rho_{n-1}(y)}$$

To see that this construction again satisfies the inductive invariant assume by contradiction that we have $(0, x) \rightarrow (1, y)$ but no arrow $\text{cr}_n(x) \rightarrow \rho_n(y)$. By definition of r , there must be some z in the same fiber of p_n as $\rho_n(y)$, such that $\text{cr}_n(x) \rightarrow z$ and $\iota(z) \rightarrow y$. Since $\iota \circ \rho \rightarrow \text{id}_q$, z must be a neighbor of $\rho_n(y)$. If z is regular, there is a fiber arrow $z \rightarrow \rho_n(y)$. If z is singular, we must have $\rho_n(y) = z$. Both contradict our assumption. \square

CLD did not check that last remark.

4.2.5.4. * Realizations of truss bundles. We previously constructed mesh realizations for n -trusses, but it remains to address the case of n -truss bundles. Naively, at least for closed n -truss bundles, one could just iteratively apply the [Construction 4.2.45](#) of 1-mesh bundle structures on the stratified realizations of closed 1-truss bundles, to obtain a putative n -mesh bundle realization. However, two successive problems arise. (1) Our primary interest in mesh realization is as a weak inverse to a (suitably enriched, suitably restricted) fundamental truss functor $\text{Mesh}_n(B, g) \rightarrow \text{Trs}_n(\mathbb{F}g)$; and typically, even for a quite well behaved stratification (B, g) , the stratified

realization $\|\mathbb{P}g\|$ of the entrance path poset $\mathbb{P}g$ is not even remotely the original stratification (B, g) , so we would not have produced anything like a candidate inverse. The natural way to address that problem is to assume the stratification (B, g) is cellable and to choose a cellular refinement (B, c) ; at least for such a cellular stratification, the stratified realization $\|\mathbb{P}c\|$ is remotely like the original stratification (B, c) . (2) However, in general that stratified realization is still not exactly the original stratification, and so we will need to construct a suitable stratified retraction $(B, c) \rightarrow \|\mathbb{P}c\|$ along which we can pull back the naive mesh bundle realization. Finally then we can coarsen that pulled-back mesh bundle according to the base coarsening $(B, c) \rightarrow (B, g)$ to obtain the desired mesh realization.

We implement that strategy as follows, beginning with a choice of cellular refinement along with a stratified regular cell closure that will be needed for the subsequent retraction construction.

TERMINOLOGY 4.2.67 (Compactified cellulation). Given a cellable stratification (B, g) , a ‘compactified cellulation’ (g, c, X) is a refinement of (B, g) by a cellular stratification (B, c) , together with a dense constructible substratification $(B, c) \hookrightarrow \|X\|$, where X is a combinatorial regular cell complex. (Here dense refers to the unstratified inclusion of spaces, i.e. $\overline{B} = |X|$.) —

We can proceed directly to building the required retraction $(B, c) \rightarrow \|\mathbb{P}c\|$ from the cellular stratification of the base to the stratified realization of its fundamental poset.

CONSTRUCTION 4.2.68 (Cellular inclusion-retractions). Given a compactified cellulation (g, c, X) for a stratification (B, g) , abbreviate $Y := \mathbb{P}c$. Note that $Y \hookrightarrow X$ is a dense subposet (i.e. $X^{\geq Y} = X$), and by assumption $B \subset |X|$ is a dense subspace. Observe that the image of the realization map $|Y \hookrightarrow X|$ lands entirely in $B \subset |X|$; let

$$\text{Ci} : |Y| \hookrightarrow B$$

denote that inclusion. Construct a corresponding retraction

$$|Y| \leftarrow B : \text{Cr}$$

as follows. Consider the simplicial complex NX , i.e. the nerve of the poset X , and decompose each simplex x as a simplicial join $y \star z$, where y is the subsimplex of x spanned by vertices in Y , and z is the subsimplex spanned by vertices in $X \setminus Y$. Note that $|x| \setminus |z| \cong |y| \times [0, 1]$; define the retraction on each intersection $|x| \cap B$ by the projection $|y| \times [0, 1] \rightarrow |y|$. The resulting inclusion-retraction pair (Ci, Cr) is cell-preserving, and so provides a stratified inclusion and retraction, as required:

$$\text{Ci} : \|\mathbb{P}c\| \xrightarrow{\cong} (B, c) : \text{Cr} \quad \text{—}$$

Equipped with this retraction from the base cellular stratification, we can describe the mesh realization for closed bundles, and their maps, as follows.

CONSTRUCTION 4.2.69 (Realization of closed n -truss bundles). For a base stratification (B, g) , with a compactified cellulation (g, c, X) and the resulting cellular inclusion-retraction pair $\text{Ci} : \|\mathbb{P}c\| \rightleftarrows (B, c) : \text{Cr}$ as in the previous construction, consider a closed n -truss bundle p over the fundamental poset $\mathbb{P}g$.

Pull the bundle back along the coarsening $\mathbb{P}c \rightarrow \mathbb{P}g$; denote the result $p^c := (\mathbb{P}c \rightarrow \mathbb{P}g)^*p$. That pullback is a tower of closed 1-truss bundles

$$S_n \xrightarrow{p_n^c} S_{n-1} \xrightarrow{p_{n-1}^c} \dots \xrightarrow{p_1^c} S_0 = \mathbb{P}c .$$

The stratified realization of this tower

$$\|S_n\| \xrightarrow{\|p_n^c\|} \|S_{n-1}\| \xrightarrow{\|p_{n-1}^c\|} \dots \xrightarrow{\|p_1^c\|} \|S_0\| = \|\mathbb{P}c\|$$

obtains the structure of a closed n -mesh bundle by iterated application of Construction 4.2.45.

Next pull back that n -mesh bundle along the retraction $\text{Cr} : (B, c) \rightarrow \|\mathbb{P}c\|$, and finally coarsen the mesh bundle along the base coarsening $(B, c) \rightarrow (B, g)$ (recall the original truss bundle was constant on strata of g). The result is the ‘closed n -mesh bundle realization’ $\|p\|_{\mathbb{M}}$ of the n -truss bundle p . \square

CONSTRUCTION 4.2.70 (Realization of maps of closed n -truss bundles). Consider a stratification (B, g) with compactified cellulation (g, c, X) and the associated cellular inclusion-retraction pair $\text{Ci} : \|\mathbb{P}c\| \rightleftarrows (B, c) : \text{Cr}$. Let $F : p \rightarrow q$ be a base-preserving map of closed n -truss bundles over the fundamental poset $\mathbb{P}g$. We construct the ‘closed n -mesh bundle map realization’ $\|F\|_{\mathbb{M}} : \|p\|_{\mathbb{M}} \rightarrow \|q\|_{\mathbb{M}}$, a base-preserving n -mesh bundle map over the stratification (B, g) .

As before, let p^c and q^c denote the pullbacks of the truss bundles p and q along the coarsening $\mathbb{P}c \rightarrow \mathbb{P}g$; note that the resulting maps $p^c \rightarrow p$ and $q^c \rightarrow q$ are truss bundle coarsenings. Similarly let $F^c : p^c \rightarrow q^c$ denote the truss bundle map lifting $F : p \rightarrow q$ along those coarsenings. The stratified realization $\|F^c\| : \|p^c\| \rightarrow \|q^c\|$ is a mesh bundle map over $\|\mathbb{P}c\|$. Now lift that realization along the pullbacks $\text{Cr}^* \|p^c\| \rightarrow \|p^c\|$ and $\text{Cr}^* \|q^c\| \rightarrow \|q^c\|$, and denote the resulting mesh bundle map $\text{Cr}^* \|F^c\|$, as in the diagram:

$$\begin{array}{ccc} \text{Cr}^* \|p^c\| & \xrightarrow{\text{Cr}^* \|F^c\|} & \text{Cr}^* \|q^c\| \\ \downarrow & & \downarrow \\ \|p^c\| & \xrightarrow{\|F^c\|} & \|q^c\| \end{array}$$

Finally push forward the mesh bundle map $\text{Cr}^* \|F^c\|$ along the coarsening $(B, c) \rightarrow (B, g)$ to obtain the desired mesh bundle realization $\|F\|_{\mathbb{M}} : \|p\|_{\mathbb{M}} \rightarrow \|q\|_{\mathbb{M}}$. \square

As in the non-bundle case, to define the mesh realization for general (not closed) truss bundles, and their maps, we just need to compactify the

bundles, before realizing them and then restricting to a suitable constructible substratification.

CONSTRUCTION 4.2.71 (Realization of general n -truss bundles). Let p be an n -truss bundle over the fundamental poset $\mathbb{I}g$ of a cellable stratification (B, g) , with a compactified cellulation (g, c, X) . Form the cubical compactification \bar{p} as in [Definition 4.2.50](#). Construct the closed n -mesh bundle $\|\bar{p}\|_{\mathbb{M}}$ by the preceding construction. Finally, take the constructible substratification $\|p\|_{\mathbb{M}} \hookrightarrow \|\bar{p}\|_{\mathbb{M}}$ whose fundamental poset subtruss bundle is the cubical compactification inclusion $p \hookrightarrow \bar{p}$; the result is the **n -mesh bundle realization** $\|p\|_{\mathbb{M}}$ of the given n -truss bundle p . \square

We may finally consider the corresponding construction for maps, and the resulting functor.

CONSTRUCTION 4.2.72 (Realization of general n -truss bundle maps). Again consider a stratification (B, g) with compactified cellulation (g, c, X) , and let $F : p \rightarrow q$ be a base-preserving map of n -truss bundles over the fundamental poset $\mathbb{I}g$. Form the cubical compactification $\bar{F} : \bar{p} \rightarrow \bar{q}$ as in (the base-preserving case of) [Construction 4.2.56](#). Construct the mesh bundle map realization $\|\bar{F}\|_{\mathbb{M}} : \|\bar{p}\|_{\mathbb{M}} \rightarrow \|\bar{q}\|_{\mathbb{M}}$ according to [Construction 4.2.70](#). Finally, restrict in the source and target along the constructible substratifications $\|p\|_{\mathbb{M}} \hookrightarrow \|\bar{p}\|_{\mathbb{M}}$ and $\|q\|_{\mathbb{M}} \hookrightarrow \|\bar{q}\|_{\mathbb{M}}$ to obtain the desired **n -mesh bundle map realization** $\|F\|_{\mathbb{M}} : \|p\|_{\mathbb{M}} \rightarrow \|q\|_{\mathbb{M}}$. \square

The above realization of a truss bundle map is constructed in terms of the realization of the cubical compactification of the map. Thus, the semi-functoriality of the cubical compactification, as in [Remark 4.2.57](#), propagates to this realization; nevertheless, by [Convention 4.2.58](#), we elide the semi-ness of the resulting functoriality.

CONSTRUCTION 4.2.73 (Mesh bundle realization functor). Together, the above constructions yield the **n -mesh bundle realization functor**

$$\|-\|_{\mathbb{M}} : \text{Trs}_n(\mathbb{I}g) \rightarrow \text{Mesh}_n(B, g)$$

from the category of truss bundles over the poset $\mathbb{I}g$ to the category of n -mesh bundles over the stratification (B, g) . \square

OBSERVATION 4.2.74 (Mesh bundle realization is right inverse). As in the non-bundle case of [Observation 4.2.62](#), after restricting either to closed mesh and truss bundles and their singular maps, or to open mesh and truss bundles and their regular maps, the mesh bundle realization of [Construction 4.2.73](#) is right inverse to the fundamental truss bundle functor of [Corollary 4.2.19](#), in the sense that there is a unique natural isomorphism $\mathbb{I}_{\top} \circ \|-\|_{\mathbb{M}} \cong \text{id}$.

Again as in the non-bundle case, forgetting the enrichment of the target of the functor in [Construction 4.2.73](#) provides a realization $\|-\|_{\mathbb{M}} : \text{Trs}_n(\mathbb{I}g) \rightarrow \text{Mesh}_n(B, g)$, which is, without restriction, right inverse to the fundamental truss bundle functor $\mathbb{I}_{\top} : \text{Mesh}_n(B, g) \rightarrow \text{Trs}_n(\mathbb{I}g)$. \square

Note that we have restricted attention to realizations of base-preserving maps of truss bundles. That restriction is partly for simplicity and brevity, though also reflects the fact that, when allowing non-base-preserving maps, the fundamental truss functor $\mathbb{I}_\top : \text{MeshBun}_n \rightarrow \text{TrsBun}_n$ destroys even the homotopy class of the base map and so cannot possibly have a weak inverse.

REMARK 4.2.75 (Higher homotopical structure of base stratifications). To correctly capture the higher homotopical structure of base stratifications and their maps in our construction of mesh bundle realization functors, we briefly describe two possible avenues of generalization.

If desired, add remark here on the non-base-preserving case. Need to restrict or lift to cellular base stratifications.

First, one may generalize combinatorial base structures from fundamental posets to fundamental ∞ -categories: truss and mesh bundles are naturally replaced by their categorical analogs in this case, see Remark 4.2.3. However, our definition of fundamental ∞ -categories in terms of quasicategories does not lend itself to a topologically faithful construction of realizations (rather, realizations become ‘homotopically faithful’, recovering original spaces and maps only up to stratified homotopy equivalence), making it less useful for certain key construction in combinatorial topology.³⁶

A second approach requires choices of combinatorial representations for both stratifications *and* their maps at the outset: in essence, in addition to choosing compactified cellulations, we also chose cellular maps between those cellulations to represent our stratified maps. (This is akin to the classical combinatorial-topological situation where all maps are combinatorially represented; the machinery of compactifications developed in this section generalizes the classical setup to work not only with closed cellular structures but also their ‘dual’ open counterparts.) Truss bundles and their maps carry these choices of combinatorial representatives in the form of appropriate coarsenings, which then allows us to realize bundles and maps in a functorial way, using a straight-forward generalization of the preceding constructions. \square

4.2.5.5. \star Realizations of truss coarsenings. The mesh realization $\|-\|_{\mathbb{M}} : \text{Trs}_n \rightarrow \text{Mesh}_n$ constructed in the preceding sections provides a right inverse to the fundamental truss $\mathbb{I}_\top : \text{Mesh}_n \rightarrow \text{Trs}_n$. However, the mesh realization of a truss coarsening is not necessarily a mesh coarsening; thus the mesh realization does not restrict to a functor from the category $\text{Trs}_n^{\text{crs}}$ of n -trusses and their coarsenings to the category $\text{Mesh}_n^{\text{crs}}$ of n -meshes and their coarsenings. We remedy this situation by constructing a distinct *mesh coarsening realization* functor $\|-\|_{\mathbb{M}}^{\text{crs}} : \text{Trs}_n^{\text{crs}} \rightarrow \text{Mesh}_n^{\text{crs}}$, with the feature that for any n -truss coarsening $F : T \rightarrow S$, the mesh coarsening realization $\|F\|_{\mathbb{M}}^{\text{crs}} : \|T\|_{\mathbb{M}} \rightarrow \|S\|_{\mathbb{M}}$ is homotopic, as a map of n -meshes, to the ordinary mesh realization $\|F\|_{\mathbb{M}}$.

CONSTRUCTION 4.2.76 (Mesh coarsening realizations of closed truss coarsenings). Given closed n -trusses $T = (p_n, \dots, p_1)$ and $S = (q_n, \dots, q_1)$,

³⁶An alternative definition of fundamental ∞ -categories, based on ‘posets with weak equivalences’, is described in Section B.3.3 and remedies this shortcoming.

and a coarsening $F : T \rightarrow S$, we construct an n -mesh coarsening $\|F\|_M^{\text{crs}} : \|T\|_M \rightarrow \|S\|_M$, with the following properties:

- › the fundamental truss $\Pi_{\top} \|F\|_M^{\text{crs}}$ is the given coarsening F ;
- › the components $\|F_i\|_M^{\text{crs}} := (\|F\|_M^{\text{crs}})_i : \|T_i\|_M \rightarrow \|S_i\|_M$ are *linear* on each simplex of the realization $\|T_i\|_M = \|T_i\|$.

Assume inductively that we have constructed the mesh coarsening realization $\|F_{<n}\|_M^{\text{crs}} : \|T_{<n}\|_M \rightarrow \|S_{<n}\|_M$, with the indicated properties. Define the top component $\|F_n\|_M^{\text{crs}} : \|T_n\|_M \rightarrow \|S_n\|_M$ on the vertices $x \in T_n \subset \|T_n\| = \|T_n\|_M$ as follows. For each element $y \in T_{n-1}$, for all the elements $x \in T_n$ in the fiber of the 1-truss bundle p_n over y , pick image points $\|F_n\|_M^{\text{crs}}(x)$ in the fiber of the 1-mesh bundle q_n over $\|F_{n-1}\|_M^{\text{crs}}(y)$, subject to the following conditions:

- › there is a strict inequality $\|F_n\|_M^{\text{crs}}(x) < \|F_n\|_M^{\text{crs}}(x')$ (in the framed realization order of the 1-mesh fiber) whenever $x \prec x'$ (in the frame order of the 1-truss fiber).
- › the image point $\|F_n\|_M^{\text{crs}}(x)$ lies in the stratum of $\|S_n\|_M = \|S_n\|$ corresponding to the poset element $F_n(x) \in S_n$.

Next extend the map $\|F_n\|_M^{\text{crs}}$ linearly to all simplices of the realization $\|T_n\|_M = \|T_n\|$. The resulting map $\|F_n\|_M^{\text{crs}}$ is a coarsening, and thus the realization $\|F\|_M^{\text{crs}}$ is an n -mesh coarsening as desired. —

Recall from [Construction 4.2.59](#) that the mesh map realization of a truss map was constructed as a substratification of the mesh map realization of the cubical compactification of [Construction 4.2.56](#). For coarsenings, the approach is similar, except that we will utilize a distinct compactification map, as follows.

OBSERVATION 4.2.77 (Cubically compactified coarsening). Let $F : T \rightarrow S$ be a coarsening map of n -trusses. There is a unique coarsening map $\overline{F}^{\text{crs}} : \overline{T} \rightarrow \overline{S}$ between the cubical compactifications, such that the following two squares commute:

$$\begin{array}{ccc} \overline{T} & \xrightarrow{\overline{F}^{\text{crs}}} & \overline{S} \\ \text{cr} \left(\downarrow \right) \text{ci} & & \text{cr} \left(\downarrow \right) \text{ci} \\ T & \xrightarrow{F} & S \end{array} .$$

We refer to this map $\overline{F}^{\text{crs}} : \overline{T} \rightarrow \overline{S}$ as the ‘cubically compactified coarsening’, and note well that this map is *not* the cubical compactification, in the sense of [Construction 4.2.56](#), of the coarsening F . (The dangerously close terminology is defensible since the cubical compactification of a coarsening is typically not itself a coarsening.)

We omit the explicit construction of cubically compactified coarsenings, which proceeds inductively in a similar spirit to the construction of the ordinary cubical compactifications. (Key in this inductive construction is that, every coarsening of 1-truss bundles factors as a base-preserving coarsening followed by a pullback; as the latter is preserved by cubical compactification

of 1-truss bundles in the sense of Construction 4.2.65, this reduces our claim to the case of 1-mesh bundles over a fixed base.)

Note that unlike the semifunctoriality of cubical compactification, from Remark 4.2.57, the cubically compactified coarsening construction preserves identities and so is properly functorial. \square

CONSTRUCTION 4.2.78 (Mesh coarsening realizations of truss coarsenings). Given n -trusses T and S and a coarsening $F : T \rightarrow S$, we construct the ‘mesh coarsening realization’ $\|F\|_{\mathbb{M}}^{\text{crs}} : \|T\|_{\mathbb{M}} \rightarrow \|S\|_{\mathbb{M}}$, with similar properties to the closed case:

- › the fundamental truss $\mathbb{T}\|F\|_{\mathbb{M}}^{\text{crs}}$ is the given coarsening F ;
- › the components $\|F_i\|_{\mathbb{M}}^{\text{crs}} := (\|F\|_{\mathbb{M}}^{\text{crs}})_i : \|T_i\|_{\mathbb{M}} \rightarrow \|S_i\|_{\mathbb{M}}$ are linear on each open simplex of the realization $\|T_i\|_{\mathbb{M}} \hookrightarrow \|\bar{T}_i\|_{\mathbb{M}}$.

Apply Observation 4.2.77 to obtain the cubically compactified coarsening $\bar{F}^{\text{crs}} : \bar{T} \rightarrow \bar{S}$, and then apply Construction 4.2.76 to obtain the mesh coarsening $\|\bar{F}^{\text{crs}}\|_{\mathbb{M}}^{\text{crs}} : \|\bar{T}\|_{\mathbb{M}} \rightarrow \|\bar{S}\|_{\mathbb{M}}$. Lift that coarsening along the constructible substratifications $\|\text{ci}\|_{\mathbb{M}} : \|T\|_{\mathbb{M}} \hookrightarrow \|\bar{T}\|_{\mathbb{M}}$ and $\|\text{ci}\|_{\mathbb{M}} : \|S\|_{\mathbb{M}} \hookrightarrow \|\bar{S}\|_{\mathbb{M}}$ to yield the desired coarsening $\|F\|_{\mathbb{M}}^{\text{crs}} : \|T\|_{\mathbb{M}} \rightarrow \|S\|_{\mathbb{M}}$. \square

Because by construction $\|F\|_{\mathbb{M}}^{\text{crs}}$ and $\|F\|_{\mathbb{M}}$ have the same fundamental truss map, i.e. $\mathbb{T}\|F\|_{\mathbb{M}}^{\text{crs}} = F = \mathbb{T}\|F\|_{\mathbb{M}}$, it follows from Proposition 4.2.40 and Remark 4.2.41 that the mesh coarsening realization $\|F\|_{\mathbb{M}}^{\text{crs}}$ and the mesh map realization $\|F\|_{\mathbb{M}}$ are homotopic mesh maps; in that sense the mesh coarsening realization is a suitable homotopical replacement for the mesh map realization.

OBSERVATION 4.2.79 (Mesh realizations of degeneracies of trusses). Note that the mesh realization exhibits an asymmetry between coarsenings and degeneracies. Though coarsenings require the above special treatment to ensure their realization are again coarsenings, degeneracies require no such care. Indeed, given a degeneracy map $F : T \rightarrow S$ of trusses, the mesh map realization $\|F\|_{\mathbb{M}} : \|T\|_{\mathbb{M}} \rightarrow \|S\|_{\mathbb{M}}$ is a degeneracy of meshes, and so the mesh realization restricts to a functor $\|-\|_{\mathbb{M}} : \text{Trs}_n^{\text{deg}} \rightarrow \text{Mesh}_n^{\text{deg}}$, providing the expected right inverse to the restricted fundamental truss functor $\mathbb{T} : \text{Mesh}_n^{\text{deg}} \rightarrow \text{Trs}_n^{\text{deg}}$. \square

4.2.6. Proofs of the equivalences and their applications. We finally assemble the proof of Theorem 4.2.1 and Theorem 4.2.2, that the fundamental truss functor and the mesh realization functor provide weak equivalences between (certain) ∞ -categories of meshes and 1-categories of trusses, and similarly for mesh bundles and truss bundles.

PROOF OF THEOREM 4.2.1 AND THEOREM 4.2.2. It suffices to show that the fundamental truss functors $\mathbb{T} : \mathring{\text{Mesh}}_n(B, g) \rightarrow \mathring{\text{Trs}}_n(\mathbb{T}g)$ and $\mathbb{T} : \mathring{\text{Mesh}}_n(B, g) \rightarrow \mathring{\text{Trs}}_n(\mathbb{T}g)$ are weak equivalences of ∞ -categories. We argue in the first (closed-singular) case; the second (open-regular) case is analogous. We need to check the following (see [Lur09, Def. 1.1.3.6]):

CXD to check the above observation. CLD has not. Need to think through bordisms with different endpoint types, and inductive extensions and such.

- (1) for each closed n -truss bundle q , there exists a closed n -mesh bundle p whose fundamental truss bundle $\mathbb{P}_\top(p)$ is equivalent to the given truss bundle q ;
- (2) for each pair of mesh bundles p and p' , the fundamental truss functor hom-space map $\mathbb{P}_\top : \bar{\mathcal{M}}esh_n(B, g)(p, p') \rightarrow \bar{\mathcal{T}}rs_n(\mathbb{P}_\top g)(\mathbb{P}_\top(p), \mathbb{P}_\top(p'))$ is a weak equivalence of topological spaces.

The first statement is immediate from [Construction 4.2.69](#) of the mesh bundle realization $\|q\|_{\mathbb{M}}$ with fundamental truss bundle $\mathbb{P}_\top\|q\|_{\mathbb{M}} = q$; see also [Construction 4.2.73](#) and [Observation 4.2.74](#). The second statement follows from the weak faithfulness of the fundamental truss functor, as in [Proposition 4.2.40](#), together with the observation that the fibers of the fundamental truss hom-space map are never empty. That non-emptiness is ensured by the mesh bundle map realization, as in [Construction 4.2.70](#), with again reference to [Construction 4.2.73](#) and [Observation 4.2.74](#). \square

In particular, we thus note that the ∞ -category $\bar{\mathcal{M}}esh_n$ (and similarly $\mathring{\mathcal{M}}esh_n$) is 1-truncated, and thus can be thought of as an ordinary 1-category (cf. [\[Lur09, Prop. 2.3.4.18\]](#)).

PROOF OF THEOREM 4.2.5. The induced functor $\mathbb{P}_\top : \mathcal{MBord}_n \rightarrow \mathcal{NTBord}^n$ sends a $[k]$ -simplex of \mathcal{MBord}_n , which by definition is an n -mesh bundle p over the stratified k -simplex $\|[k]\|$, to the classifying functor $\chi_{\mathbb{P}_\top p} : [k] \rightarrow \mathcal{TBord}^n$ (see [Construction 2.3.44](#)) of the fundamental truss $\mathbb{P}_\top p$.

To show that this functor \mathbb{P}_\top is a trivial fibration (see [\[Lur09, Ex. 2.0.0.2\]](#)) we need to show that it has the right lifting property with respect to the boundary inclusion $\partial\Delta[k] \hookrightarrow \Delta[k]$ (where $\Delta[k]$ is the simplicial set represented by the poset $[k]$).

Suppose we have maps $\alpha : \partial\Delta[k] \rightarrow \mathcal{MBord}_n$ and $\beta : \Delta[k] \rightarrow \mathcal{NTBord}^n$ such that $\mathbb{P}_\top \circ \alpha = \beta|_{\partial\Delta[k]}$. First, reinterpret $\beta : \Delta[k] \rightarrow \mathcal{NTBord}^n$ as a functor $[k] \rightarrow \mathcal{TBord}^n$; that functor classifies an n -truss bundle q over $[k]$. By [Construction 4.2.73](#), we have an n -mesh bundle realization $\|q\|_{\mathbb{M}}$ over the stratified simplex $\|[k]\|$. Second, restricting the map α to each facet of $\partial\Delta[k]$ defines a mesh bundle on that facet; glue those mesh bundles together to obtain an n -mesh bundle p over the boundary $\partial\|[k]\|$. (That this gluing is indeed a *posetal* mesh bundle relies on the existence of the filling map β .) By construction, the restricted mesh bundle $\|q\|_{\mathbb{M}}|_{\partial\|[k]\|}$ and the glued mesh bundle p have the same fundamental truss bundles. Apply [Proposition 4.2.22](#) to provide a bundle isomorphism $\kappa : p \cong \|q\|_{\mathbb{M}}|_{\partial\|[k]\|}$.

Identify the stratified simplex with the stratified simplex with an additional boundary collar: $\|[k]\| \cong \|[k]\| \cup_{\partial\|[k]\| \cong \partial\|[k]\| \times \{1\}} (\partial\|[k]\| \times [0, 1])$. Finally construct the required filler $\bar{\alpha} : \|[k]\| \rightarrow \mathcal{MBord}_n$ as follows: define the filler on the collar $\partial\|[k]\| \times [0, 1]$ to be the mapping cylinder of the bundle isomorphism κ , then extend over the remaining simplex $\|[k]\|$ by the bundle $\|q\|_{\mathbb{M}}$.

Any trivial fibration induces an equivalence of quasicategories as claimed; see [Rez22, §23.10]. \square

SYNOPSIS. Having completed the proofs of the equivalences between meshes and trusses, we proceed to two applications. First, we introduce mesh blocks and the notion of framed subdivision of framed cells, and then provide a classification of such subdivisions in terms of combinatorial subdivisions of truss blocks. Second, we introduce mesh braces and observe the duality between mesh blocks and braces and more generally the duality equivalence of closed and open meshes.

4.2.6.1. Mesh blocks and subdivisions of framed regular cells. Concatenating the equivalence of meshes and trusses, with the previous equivalence of trusses and collapsible framed cell complexes, provides of course a relationship between meshes and collapsible framed cell complexes, which will in turn allow us to define a notion of framed subdivision of framed cells, and then to classify such subdivisions in terms of combinatorial subdivisions of truss blocks.

From Theorem 4.2.1, we have the equivalence of closed meshes and closed trusses, witnessed by the fundamental truss $\mathbb{1}_T$ and mesh realization $\|-\|_M$. From the earlier Theorem 3.1.2, we have the equivalence of closed trusses and collapsible framed cell complexes, witnessed by the cell gradient ∇_C and truss integration f_T . As in Terminology 4.2.7, we compose these functors to define the mesh-to-cell gradient functor $\nabla_{MC} := \nabla_C \circ \mathbb{1}_T$ and the cell-to-mesh realization functor $\|-\|_{CM} := \|-\|_M \circ f_T$, witnessing the following equivalence.

COROLLARY 4.2.80 (Equivalence of closed meshes and collapsible framed cell complexes). *The mesh-to-cell gradient functor ∇_{MC} and the cell-to-mesh realization functor $\|-\|_{CM}$ provide a weak equivalence*

$$\begin{array}{ccc} \bar{\text{Mesh}}_n & \begin{array}{c} \xrightarrow{\nabla_{MC}} \\ \xleftarrow{\|-\|_{CM}} \end{array} & \text{CollFrCellCplx}_n \end{array}$$

between the ∞ -category of closed n -meshes and the 1-category of collapsible n -framed regular cell complexes.

Recall that the equivalence between trusses and collapsible framed cell complexes restricted to an equivalence between truss blocks and framed cells. We can transport that restriction across the mesh-to-truss equivalence as follows.

DEFINITION 4.2.81 (Mesh blocks). An n -**mesh block** is a closed n -mesh whose total space is the closure of a single stratum. It is more specifically an n -**mesh** m -**block** if that dense stratum is of dimension m . \square

REMARK 4.2.82 (Mesh blocks and truss blocks). Mesh blocks are exactly those closed meshes whose fundamental truss is a truss block. \square

EXAMPLE 4.2.83 (Mesh blocks). Back in Figure I.6, the first closed mesh is a 3-mesh 3-block. The fundamental truss of that mesh was depicted (on the right) in Figure 3.1, along with (on the left) the corresponding framed regular cell; that cell bears an unmistakable resemblance to the total stratification of the mesh block.

By contrast, in Figure I.6, the second closed mesh is not a mesh block, but has two submeshes, each of which is a mesh block. The front one of those two mesh blocks has fundamental truss block depicted (on the right) in the middle example of Figure C.6, along with (on the left) the corresponding framed regular cell.

The mesh realization of any truss block is of course a mesh block; so the mesh realizations of the truss blocks of Figures 2.51 and 2.52 provide two further examples. —

COROLLARY 4.2.84 (Equivalence of mesh blocks and framed cells). *The mesh-to-cell functor ∇_{MC} and the cell-to-mesh functor $\|-\|_{\text{CM}}$ provide a weak equivalence between the ∞ -category of n -mesh blocks (as a full subcategory of Mesh_n) and the 1-category of n -framed regular cells.*

OBSERVATION 4.2.85 (Stratified realizations and cell-to-mesh realizations). Since mesh realizations of closed trusses are constructed using ordinary stratified realizations, it follows that for any collapsible framed regular cell complex (X, \mathcal{F}) , there is a canonical stratified homeomorphism $\|(X, \mathcal{F})\|_{\text{CM}} \cong \|X\|$ of the total stratification of cell-to-mesh realization and the stratified realization of the combinatorial regular cell complex X (as seen above in Example 4.2.83). —

The translation of framed regular cells into mesh blocks provides a framed topological realization of framed regular cells, namely via the n -framed realization of the mesh block, as in Construction 4.1.70.³⁷ We can leverage this framed topological realization to define a notion of *framed subdivisions* of framed regular cells.

For context, first recall the notion of (unframed) subdivision of a combinatorial regular cell.

TERMINOLOGY 4.2.86 (Subdivisions of regular cells). Let X be a combinatorial regular cell. A ‘subdivision’ of X is a combinatorial regular cell complex Y , together with a stratified coarsening $F : \|Y\| \rightarrow \|X\|$ of stratified realizations. —

³⁷Note that the n -framed realization of the cell-to-mesh realization of a framed cell need not be a framed realization of the framed cell in the sense of Terminology 1.3.37 because it is not necessarily linear on each simplex of the underlying framed simplicial complex of the cell. That discrepancy is not serious, though, since the cell-to-mesh realization of a framed cell is always homotopic to a realization that is in fact linear on each simplex.

A subdivision $F : \|Y\| \rightarrow \|X\|$ typically restricts, on a closed cell $\|Y^{\geq y}\| \hookrightarrow \|Y\|$, $y \in Y$, to a non-cellular map $F|_{Y^{\geq y}} : \|Y^{\geq y}\| \hookrightarrow \|X\|$ (see [Definition 1.3.19](#)). In this sense, the notion of subdivision of cells is not immediately combinatorializable. In fact, no *computable* combinatorial description whatsoever exists, in the sense that subdivisions of cells cannot be recognized or enumerated by any algorithmic method.

The framed analog of subdivisions of combinatorial regular cells is given as follows.

DEFINITION 4.2.87 (Framed subdivisions of framed regular cells). Let (X, \mathcal{F}) be an n -framed regular cell. A **framed subdivision** of (X, \mathcal{F}) is an n -framed regular cell complex (Y, \mathcal{G}) , together with a stratified coarsening $F : \|Y\| \rightarrow \|X\|$ of stratified realizations, such that, for each closed cell $Y^{\geq y}$, $y \in Y$, the restriction $F|_{Y^{\geq y}} : \|(Y^{\geq y}, \mathcal{G}|_{Y^{\geq y}})\|_{\text{CM}} \hookrightarrow \|(X, \mathcal{F})\|_{\text{CM}}$ is a mesh map. —

That these are called ‘framed’ subdivisions is appropriate because maps of meshes are intrinsically framed; consider [Observation 4.1.88](#), which notes that the top component of a mesh map provides an n -framed map of euclidean subspaces in the sense of [Definition 4.1.86](#). (Note that in this definition of a framed subdivision, the subdividing complex (Y, \mathcal{G}) is not assumed to be collapsible; but it will be a consequence of the classification of framed subdivisions that any subdividing complex is in fact collapsible.)

EXAMPLE 4.2.88 (Framed subdivisions). In [Figure 4.24](#), we illustrate various subdivisions of the central square framed cell. The top row shows four framed regular cell complexes and indicates implicit corresponding coarsening maps, providing framed subdivisions of the framed cell. The bottom row shows four framed regular cell complexes, obtained from the top row by small changes to the cell structure or framings; each of these complexes does coarsen to the square cell, and so provides a non-framed subdivision, but those coarsenings are not (and cannot be chosen to be) framed subdivisions. —

TERMINOLOGY 4.2.89 (Combinatorial subdivisions of truss blocks). Let B be an n -truss block. A ‘combinatorial subdivision’ of the block B is a closed n -truss T , together with a truss coarsening $T \rightarrow B$. (Given such a combinatorial subdivision, we will also say that the truss combinatorially subdivides the framed cell corresponding to the truss block.) —

By contrast with ordinary subdivisions, framed subdivisions admit a combinatorial and indeed computable classification; specifically, according to [Theorem 4.2.8](#), framed subdivisions of framed cells (in the sense of [Definition 4.2.87](#)) correspond to combinatorial subdivisions of truss blocks (in the sense of [Terminology 4.2.89](#)), which are themselves algorithmically recognizable and enumerable. We may now give the proof, which proceeds by induction on the cell dimension, using the notions of spacer and section simplices developed in [Section 3.3.1](#).

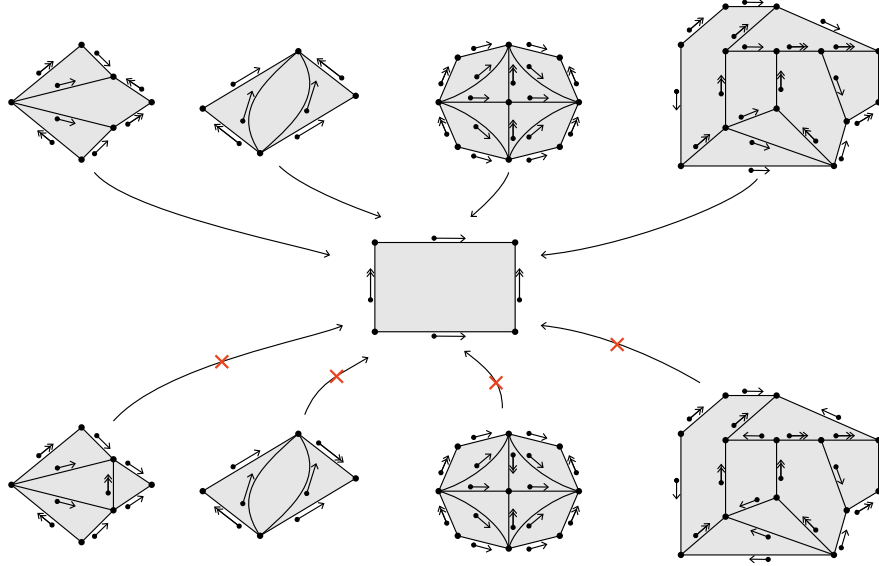

FIGURE 4.24. Framed subdivisions and non-framed subdivisions of the 2-framed square cell.

PROOF OF THEOREM 4.2.8. Suppose we have a framed regular cell (X, \mathcal{F}) and a framed regular cell complex (Y, \mathcal{G}) , together with a truss block B whose cell gradient $\nabla_{\mathcal{C}} B$ is the framed cell X and a closed truss T whose cell gradient $\nabla_{\mathcal{C}} T$ is the framed cell complex Y ; suppose moreover that the truss T combinatorially subdivides the block B via the truss coarsening $F : T \rightarrow B$. We need to produce a corresponding framed subdivision of the cell X by the complex Y ; that is, by definition, a stratified coarsening $\|Y\| \rightarrow \|X\|$ of stratified realizations, which is a mesh map on each closed cell.

Consider the mesh coarsening realization $\|F\|_{\mathbf{M}}^{\text{crs}} : \|T\|_{\mathbf{M}} \rightarrow \|B\|_{\mathbf{M}}$, from Construction 4.2.76, and more specifically its total stratified map $(\|F\|_{\mathbf{M}}^{\text{crs}})_n : (\|T\|_{\mathbf{M}})_n \rightarrow (\|B\|_{\mathbf{M}})_n$. Recall that the total stratification of the mesh realization is the stratified realization of the total truss poset, which is the stratified realization of the cell gradient (by Construction 3.3.17), which by assumption is the framed cell complex:

$$(\|T\|_{\mathbf{M}})_n = \|T_n\| = \|\nabla_{\mathcal{C}} T\| = \|(Y, \mathcal{G})\|.$$

Similarly $(\|B\|_{\mathbf{M}})_n = \|(X, \mathcal{F})\|$. Thus the total stratified map of the mesh coarsening realization provides the required stratified coarsening $\|Y\| \rightarrow \|X\|$, and by construction it is a mesh map on cells as required.

Conversely, suppose we have an n -framed regular cell (X, \mathcal{F}) and an n -framed regular cell complex (Y, \mathcal{G}) , together with a framed subdivision, i.e. a stratified coarsening $F : \|Y\| \rightarrow \|X\|$, which is a mesh map on closed cells. We need to produce a truss T and truss block B , whose cell gradients are

the complex Y and the cell X respectively, together with a truss coarsening $T \rightarrow B$.

Assume by induction that we have the desired implication for $(n - 1)$ -framed cells and cell complexes. Now, consider the case when the n -framed cell (X, \mathcal{F}) is a section cell. Necessarily, in this case, all the cells of the complex (Y, \mathcal{G}) are also section cells. Recall from [Construction 3.3.12](#) that we may form the integral proframed cell of the n -framed cell (X, \mathcal{F}) , and since it is a section cell, the first map in that proframe tower has the form $(X, \mathcal{F}) \rightarrow (X, \mathcal{F}_{n-1})$; in particular that map induces an isomorphism of stratified realizations. Similarly, the first map of the integral proframe of each closed cell of the subdivision has the form $(Y^{\geq y}, \mathcal{G}|_{Y^{\geq y}}) \rightarrow (Y^{\geq y}, (\mathcal{G}|_{Y^{\geq y}})_{n-1})$. Let (Y, \mathcal{G}_{n-1}) denote the complex of the projected cells $(Y^{\geq y}, (\mathcal{G}|_{Y^{\geq y}})_{n-1})$, and note that the map of complexes $(Y, \mathcal{G}) \rightarrow (Y, \mathcal{G}_{n-1})$ induces an isomorphism of stratified realizations. Of course the subdivision F of (X, \mathcal{F}) by (Y, \mathcal{G}) induces a subdivision F_{n-1} of (X, \mathcal{F}_{n-1}) by (Y, \mathcal{G}_{n-1}) . By induction, the framed complex (Y, \mathcal{G}_{n-1}) is collapsible and the subdivision F_{n-1} has a corresponding combinatorial subdivision, i.e. an $(n - 1)$ -truss coarsening $T^{n-1} \rightarrow B^{n-1}$; that coarsening may be considered (by adding identities at the top) as an n -truss coarsening $T^n \rightarrow B^n$, providing the desired combinatorial subdivision for the framed subdivision F .

Next, consider the case when the n -framed cell (X, \mathcal{F}) is a spacer cell. Let $\partial_- X$ denote the lower section cell of the spacer (X, \mathcal{F}) , and let $\partial_- Y$ denote the framed complex determined by the preimage of the section $\partial_- X$ under the subdivision F . Observe that the framed subdivision F restricts to a framed subdivision $F_- : \|\partial_- Y\| \rightarrow \|\partial_- X\|$. The top 1-mesh bundle p_n of the n -mesh $\|(X, \mathcal{F})\|_{\text{CM}}$ induces a map $q_n : \|Y\| \rightarrow \|\partial_- Y\|$ such that the following diagram commutes:

$$\begin{array}{ccc} \|Y\| & \xrightarrow{F} & \|X\| \\ q_n \downarrow & & \downarrow p_n \\ \|\partial_- Y\| & \xrightarrow{F_-} & \|\partial_- X\| \end{array}$$

The map q_n is in fact a 1-mesh bundle (and F is a map of 1-mesh bundles); that follows by separate consideration of each cell in the base $\|\partial_- Y\|$, using induction up the section-and-spacer tower of cells over each given cell of the base. By induction, the base $\|\partial_- Y\|$ is the total stratification of an $(n - 1)$ -mesh (and F_- is a map of $(n - 1)$ -meshes), and so the map q_n provides the top 1-mesh bundle of an n -mesh; let M denote that n -mesh and abuse notation by referring to the resulting mesh coarsening also simply as F . By construction, the mesh-to-cell gradient $\nabla_{\text{MC}} M$ is the cell complex (Y, \mathcal{G}) . Thus the complex (Y, \mathcal{G}) is collapsible, with the fundamental truss $\mathbb{P}_{\top} M$ having cell gradient $\nabla_{\text{C}} \mathbb{P}_{\top} M \cong (Y, \mathcal{G})$, and the required combinatorial subdivision is given by the fundamental truss map of the mesh map F . \square

EXAMPLE 4.2.90 (Combinatorial subdivisions). Figure 4.24 depicted four framed subdivisions of the square framed 2-cell. Such subdivisions are classified, according to Theorem 4.2.8, by truss coarsenings of the 2-truss integrating that framed 2-cell. In Figure 4.25, we illustrate the mesh realizations (via their framed embeddings in \mathbb{R}^2) of the four trusses that classify the given four framed subdivisions. \square

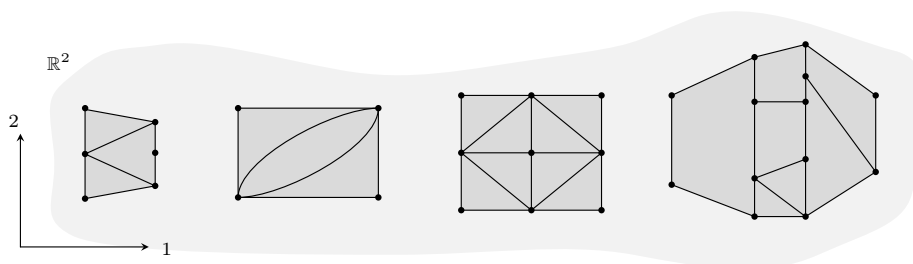

FIGURE 4.25. Mesh realizations of combinatorial subdivisions of the 2-framed square cell.

OBSERVATION 4.2.91 (Space of framed subdivisions). Given a framed cell (X, \mathcal{F}) and a fixed collapsible framed cell complex (Y, \mathcal{G}) , the space $\text{SubDiv}((Y, \mathcal{G}); (X, \mathcal{F}))$ of framed subdivisions of that cell by that complex (i.e. the space of stratified coarsenings that are cell-wise mesh maps) can be identified with the space of mesh coarsenings $\text{Mesh}_n^{\text{crs}}(\|(Y, \mathcal{G})\|_{\text{CM}}, \|(X, \mathcal{F})\|_{\text{CM}})$. The fundamental truss map $\mathbb{T} : \text{SubDiv}((Y, \mathcal{G}); (X, \mathcal{F})) \rightarrow \text{Trs}_n^{\text{crs}}(f_{\mathbb{T}}(Y, \mathcal{G}), f_{\mathbb{T}}(X, \mathcal{F}))$, from such subdivisions to truss coarsenings, is a weak homotopy equivalence. \square

REMARK 4.2.92 (Framed subdivisions can be made piecewise linear). Of course a priori a framed subdivision may be a highly nonlinear stratified map from the cell complex (Y, \mathcal{G}) to the cell (X, \mathcal{F}) . But recall, from Construction 4.2.78, that we constructed piecewise linear mesh coarsening realizations of truss coarsenings, and recall, from the comments following that construction, that mesh coarsening realization is right inverse to the fundamental truss. It follows then from the preceding observation that any framed subdivision is homotopic to a piecewise linear framed subdivision. \square

REMARK 4.2.93 (Concrete computability of framed versus simplicial subdivision). Since framed subdivisions are classified in terms of truss coarsenings, and truss coarsenings are a finitely determined combinatorial structure which may be enumerated at worst by brute exhaustion, framed subdivisions are, as advertised, decidable enumerable. This feature is in contrast to for instance unframed simplicial subdivisions (or the theory of subdivision for various other combinatorial shapes), which are not specified or classified by the morphisms in any finitary combinatorial category. Indeed, the most effective

combinatorial specification of a simplicial subdivision of a simplex is as a path, of a priori unbounded length, of Pachner moves (see [Pac91]). \square

4.2.6.2. Dualization of meshes. As a immediate corollary of the dualization of trusses and the equivalence of meshes and trusses, we now construct the dualization functors between the category of closed meshes with singular maps and the category of open meshes with regular maps.

PROOF OF COROLLARY 4.2.9. The ‘mesh dualization’ functors

$$\dagger : \bar{\mathcal{M}}esh_n \simeq \mathring{\mathcal{M}}esh_n : \dagger$$

are defined as the following composites:

$$\bar{\mathcal{M}}esh_n \begin{array}{c} \xrightarrow{\mathbb{P}_T} \\ \xleftarrow{\|\cdot\|_M} \end{array} \bar{\mathcal{T}}rs_n \begin{array}{c} \xleftarrow{\dagger} \\ \xrightarrow{\dagger} \end{array} \mathring{\mathcal{T}}rs_n \begin{array}{c} \xleftarrow{\|\cdot\|_M} \\ \xrightarrow{\mathbb{P}_T} \end{array} \mathring{\mathcal{M}}esh_n$$

The central arrows (labeled by ‘ \dagger ’) are the dualization functors of trusses, as described in Remark 2.3.59. Since each component functor in the composites is an equivalence, so are the mesh dualization functors. \square

Recall from Section 2.3.3.4 that the duals of truss blocks are truss braces; similarly, the duals of mesh blocks are mesh braces, as follows.

DEFINITION 4.2.94 (Mesh braces). An n -**mesh brace** is an open n -mesh whose total space has a single stratum that is in the closure of every other stratum. It is more specifically an n -**mesh m -brace** if that single ‘cone stratum’ is of dimension m . \square

EXAMPLE 4.2.95 (Mesh blocks and their dual mesh braces). In Figure 4.26, we depict a 2-mesh 2-block and its dual 2-mesh 0-brace. In the introductory Figure I.6(a), we depicted a 3-mesh 3-block and its dual 3-mesh 0-brace. That 3-mesh block corresponds to a 3-truss block and in turn to a 3-framed regular cell; that truss block and that regular cell are depicted at the top of the appendix Figure C.6. \square

EXAMPLE 4.2.96 (Closed meshes and their dual open meshes). In Figure 4.27, we depict a closed 2-mesh and its dual open 2-mesh. Similarly, in the introductory Figure I.6(b), we depicted a closed 3-mesh and its dual open 3-mesh. That closed 3-mesh contains two 3-mesh blocks, which correspond to two 3-mesh braces in the dual open 3-mesh. Each of those two 3-mesh blocks corresponds to a 3-framed regular cell; one of them is depicted in the middle of appendix Figure C.6, along with its corresponding 3-truss and its dual 3-mesh brace (and the inclusion of that brace in the larger dual 3-mesh).

Altogether then in Figure I.6 there are three mesh blocks, or equivalently three regular cells; combining those and a fourth cell, which is a vertical reflection of the first cell, gives a regular cell complex illustrated previously in Figure 1.55. \square

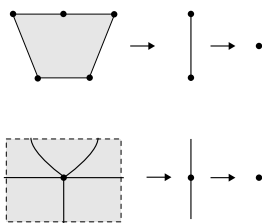

FIGURE 4.26. A mesh block and its dual mesh brace.

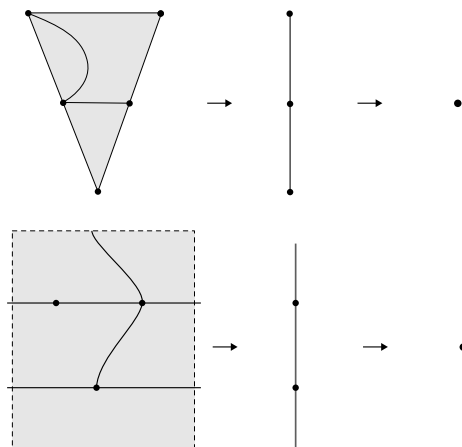
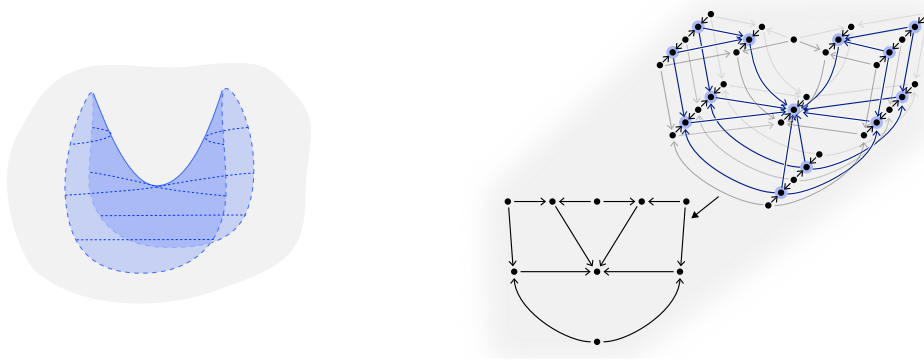

FIGURE 4.27. A closed mesh and its dual open mesh.

REMARK 4.2.97 (Dual cell complexes via compactification). We cannot naively transport the self-duality of meshes to a self-duality of regular cell complexes; given a collapsible regular cell complex, there is a corresponding closed mesh, which dualizes to an open mesh, which does not a priori correspond back to a cell complex. However, we may nevertheless provide a duality of framed complexes ‘up to compactification’ as follows. Given a collapsible framed regular cell complex (X, \mathcal{F}) , define its ‘dual complex’ to be the collapsible framed regular cell complex $\nabla_{\mathcal{C}} (\overline{f_{\mathcal{T}}(X, \mathcal{F})})^{\dagger}$, that is the cell gradient of the compactification (see Definition 4.2.50) of the dual of the integral truss of the given complex. —

CHAPTER 5

Tame stratifications and their combinatorializability



In [Chapter 2](#), we presented trusses as the core local substrate of constructible framed combinatorial structures; in [Chapter 4](#), we established meshes as the corresponding local model of constructible framed topological structures. In this final chapter, we develop framed *stratified* combinatorial and topological structures, emphasizing the theory of tame stratifications. Tame stratifications are stratified euclidean subspaces admitting a mesh refinement; we will prove there is always a coarsest such refinement and therefore a classification of tame stratifications by stratified trusses. That combinatorialization will imply that local framed stratified spaces are ultimately both polyhedral and computable.

We begin this chapter, in [Section 5.1](#), by defining tame stratifications and tame embeddings, giving an overview of their combinatorial classification, and previewing the applications concerning polyhedrality and computability. We then, in [Section 5.2](#), introduce mesh joins, establish the existence of the coarsest refining mesh of a tame stratification, and provide examples of such coarsest meshes. Next, in [Section 5.3](#), we prove the classification of tame stratifications and embeddings, prove the framed Hauptvermutung, and prove that framed stratified homeomorphism is decidable. In the final coda [Section 5.4](#), we introduce manifold diagrams, define tame tangles, tangle singularities, and tangle isotopies, and conjecture that tame tangles provide a combinatorial model of smooth structures.

5.1. Tame stratifications and tame embeddings

Recall that we have been working toward a definition of a class of stratifications that is sufficiently general as to encode all reasonable finitary topological phenomena, while still admitting a combinatorial classification and, crucially, for which the problem of equivalence is algorithmically decidable. Recall that meshes provide, via their realizations, stratified cellulations of subspaces of euclidean space, which are exceptionally well behaved, in the sense that they descend along the standard projections, constructibly and inductively, to mesh cellulations of all lower-dimensional euclidean spaces. Equipped with this foundational class of mesh stratifications, we may consider all stratifications of euclidean subspaces that admit a mesh refinement. Implicitly and terminologically asserting that such stratifications satisfy the desiderata (of finitary phenomenological generality, combinatorializability, and decidability), we call these *tame stratifications*. An example of a tame stratification is illustrated on the right in Figure 5.1; this is a stratification of an open ball in \mathbb{R}^3 with one bulk stratum, two surface strata, six line strata, and six point strata. (The thin vertical guidelines are not strata but merely convey the arrangement of the ball in the ambient euclidean space.) Because coarsening preserves tameness, another tame stratification is obtained by merging all the surface, line, and point strata into a single 2-spherical stratum.

Of course, we care about stratifications outside of euclidean space, for instance about stratifications of abstract compact manifolds. We may expand our attention to that wider context, simply by considering stratified spaces with an embedding into euclidean space, whose stratified image is a constructible substratification of a tame stratification of an open euclidean subspace. We call these *tame embeddings*, and will find that they inherit the combinatorializability and decidability properties of tame stratifications. An example of a tame stratification is illustrated by the whole of Figure 5.1; on the left is a stratification of the 2-sphere, with two surface strata, six line strata, and six point strata, and the indicated stratified embedding onto a constructible substratification of the right tame stratification. (Again, the thin guidelines are not strata but suggest the embedding by mapping to the target guidelines. The green point strata are distinguished to further disambiguate the embedding map.) Another example is obtained by merging all the strata of the source (and as before the non-bulk strata of the target); that provides a tame embedding of the unstratified 2-sphere. As it happens this embedding is the last nontrivial stage of the Morin eversion of the sphere.

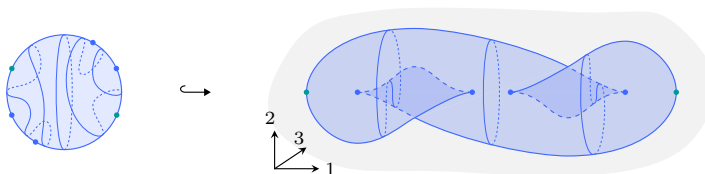

FIGURE 5.1. A tame stratification and a tame embedding.

OUTLINE. In Section 5.1.1, we define tame stratifications as stratifications admitting a mesh refinement, and tame embeddings as embeddings whose stratified image is a constructible substratification of an open tame stratification. In Section 5.1.2, we provide an overview of the combinatorial classification of tame stratifications by normalized stratified trusses. Finally in Section 5.1.3, we preview applications of the classification to polyhedrality and computability: we highlight the fact that framed stratified homeomorphisms of tame stratifications are homotopic to piecewise linear homeomorphisms, and the fact that framed stratified homeomorphism of tame stratifications is algorithmically decidable.

5.1.1. The definitions. Recall that a *coarsening* is a stratified map that is a homeomorphism of underlying spaces. Also recall that the source of a coarsening is called a *refinement* of the target. Given a coarsening, each stratum of the target is decomposed into a disjoint union of the images of strata of the source.

Given a class of stratifications, we may consider its ‘coarsening closure’, which contains all those stratifications obtained by coarsening a stratification in the given class. Applying that coarsening closure to the class of mesh stratifications provides the notion of tame stratifications, as follows. Recall that an n -mesh M comes equipped with an n -realization $\gamma : M_n \hookrightarrow \mathbb{R}^n$, and we refer to the image $\gamma(M_n) \subset \mathbb{R}^n$ as the support of the mesh.

DEFINITION 5.1.1 (Tame stratifications). An **n -tame stratification** is a stratification (Z, f) of a space $Z \subset \mathbb{R}^n$, that admits a refinement by an n -mesh. (That is, there is an n -mesh M with support $\gamma(M) = Z$, whose realization $\gamma : (M_n, f_n) \rightarrow (Z, f)$ is a coarsening.) —

TERMINOLOGY 5.1.2 (Support of a tame stratification). Given a tame stratification (Z, f) , we refer to the space $Z \subset \mathbb{R}^n$ as its ‘support’. —

Note that the support of a tame stratification is a bounded subset of euclidean space, by our standing assumption that realizations of meshes are bounded (see the comments after [Convention 4.1.13](#)). Abusing notation, we may write $M \rightarrow f$ as shorthand for the mesh refinement $(M_n, f_n) \rightarrow (Z, f)$ of a tame stratification.

It is often convenient to consider, more generally, stratifications that, though they don’t per se admit a mesh refinement, have a stratified open neighborhood that admits a mesh refinement. That generalization allows us to focus attention on the most geometrically relevant aspects of the stratification, and provides the notion of ambiently tame stratifications, as follows.

DEFINITION 5.1.3 (Ambiently tame stratifications). An **ambiently n -tame stratification** is a stratification (Y, e) of a space $Y \subset \mathbb{R}^n$, that is a constructible substratification of a tame stratification (Z, f) , with $Z \subset \mathbb{R}^n$ an open subspace. —

Though tame and ambiently tame stratifications are stratified spaces already within euclidean space, we care of course about more general spaces

and stratified spaces, in particular for instance about all manifolds. We may accommodate that wider context, by considering embeddings of abstract stratified spaces into euclidean space, with ambiently tame image, as follows.

DEFINITION 5.1.4 (Tame embeddings). An n -**tame embedding** of a stratified space (W, g) is an embedding $\iota : W \hookrightarrow \mathbb{R}^n$, whose stratified image $\iota(W, g)$ is an ambiently tame stratification. \square

We think of an n -tame embedding of a stratified space (W, g) as being a choice of expressive and informative structure, analogous to a choice of n -framing on a simplicial or regular cell complex, or more classically to a choice of Morse function on a manifold.

TERMINOLOGY 5.1.5 (Tame open neighborhoods). Given a tame embedding ι of the stratified space (W, g) , a ‘tame open neighborhood’ of the tame embedding is a choice of open neighborhood Z of the image $\iota(W)$, for which there exists a tame stratification (Z, f) containing the stratified image $\iota(W, g)$ as a constructible substratification. (When context forestalls ambiguity, we may refer to a tame open neighborhood simply as an ‘open neighborhood’.) \square

EXAMPLE 5.1.6 (2-Tame stratifications). In Figure 5.2, we depict three 2-tame stratifications. In each case the underlying space Z is the union of the colored strata (where each connected colored region represents a single stratum). The first example is a polytope Z , regarded as a subspace with trivial stratification. The second example has the same subspace Z but with a non-trivial stratification. In the third example, the subspace is neither compact nor open (dashed lines indicate open boundaries).³⁸ \square

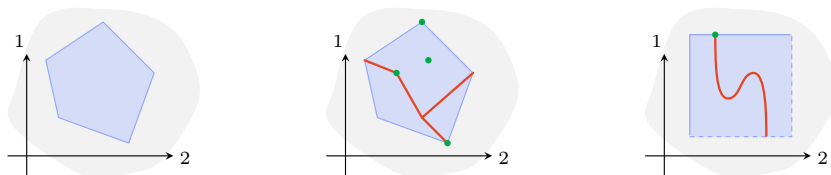

FIGURE 5.2. 2-Tame stratifications.

EXAMPLE 5.1.7 (2-Tame embeddings). In Figure 5.3, we depict three examples of 2-tame embeddings. The first example is a 2-tame embedding of the (trivially stratified) circle. The tame open neighborhood can be chosen to be the open dashed square $Z = I^2$; there is a tame stratification of that neighborhood having strata the circle and the two components of its complement. Note that we have only drawn the image of the tame embedding, and so this may also be considered simply as an example of an ambiently

³⁸Note that an example of a tame stratification that is not a tame embedding may be obtained from this example by adding to the left 2-dimensional bulk stratum the lower left corner point.

tame stratification. We almost always let the source of the tame embedding be implicit in our illustrations; however one should keep the source in mind as the abstract space or stratification that is being framed by the specific embedding. The second example is a 2-tame embedding of a stratification (by manifolds) of the wedge of two circles. The third example is a tame embedding of a different stratification of the same space, namely the stratification with a single non-manifold stratum. └─

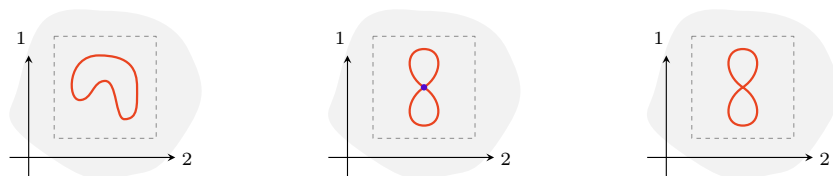

FIGURE 5.3. 2-Tame embeddings.

EXAMPLE 5.1.8 (3-Tame stratifications). In Figure 5.4, we depict three 3-tame stratifications. The first example is a 3-polytope (the associahedron as it happens), regarded as a subspace with trivial stratification. The second example is a cylinder with closed sides and open ends, stratified by a winding line stratum and its complement. The third example is a partially-closed, partially-open prism, stratified by a cuspidal surface stratum, a snaked line stratum, a point stratum, and two bulk strata of the remaining complement. └─

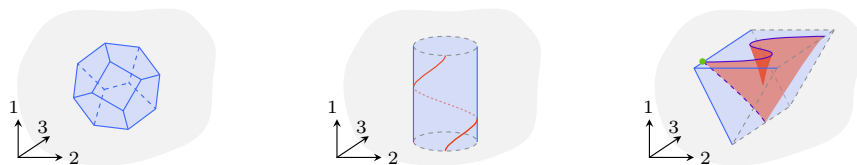

FIGURE 5.4. 3-Tame stratifications.

EXAMPLE 5.1.9 (3-Tame embeddings). In Figure 5.5, we depict three examples of 3-tame embeddings. As before we depict only the image of the embedding. The first example represents a braid structure as a tame embedding of two intervals. The second example is a 3-tame embedding of a circle, with target an unknot with nontrivial writhe. The third example is a tame embedding of a Möbius band, stratified by its interior and its boundary. (In all three cases, the tame open neighborhood can be taken to be the open dashed 3-cube.) └─

EXAMPLE 5.1.10 (4-Tame stratifications and embeddings). In Figure I.7, we depicted two 4-tame stratifications. In both cases, the subspace $Z \subset \mathbb{R}^4$ is the open 4-cube. The first stratification has three 2-dimensional substrata

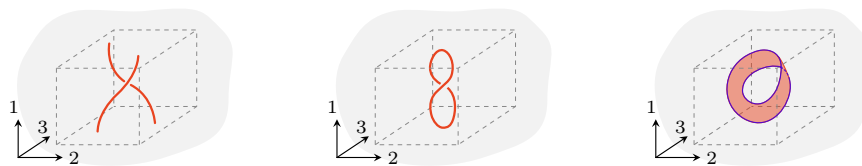

FIGURE 5.5. 3-Tame embeddings.

and a single open bulk stratum; this tame stratification encodes the classical third Reidemeister move. The second stratification has a single 3-dimensional substratum and two open bulk complement strata; this tame stratification encodes the swallowtail singularity. Discarding the bulk strata, both cases may instead be considered as ambiently tame stratifications, and indeed the given coloration more directly suggests that interpretation. Furthermore, conceiving of these stratifications as depicting the images of embeddings, the first example may be considered as a 4-tame embedding of the disjoint union of three open 2-cubes, and the second example may be considered as a 4-tame embedding of an open 3-cube. \square

EXAMPLE 5.1.11 (Untame embedding behavior). To clarify the nature of the tameness condition, in Figure 5.6 we depict a less-straightforwardly tame embedding along with an embedding that fails to be tame. The first example on the left has an infinite oscillation but nevertheless is a tame embedding of the stratified closed interval. The second example on the right also has an infinite oscillation but is not a tame embedding: the 1-dimensional stratum has infinitely many critical points with respect to the ambient standard projection $\mathbb{R}^2 \rightarrow \mathbb{R}^1$, and so no neighborhood could be refined by a mesh (as meshes have finitely many strata).

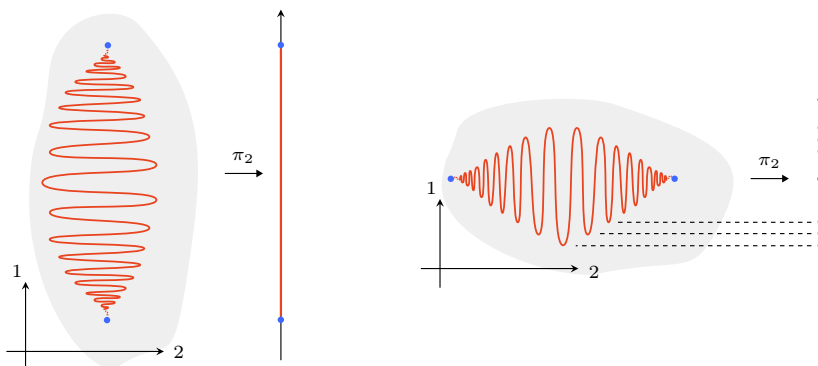

FIGURE 5.6. Tame and untame oscillations.

Embeddings can be untame without any overt infinitary behavior. For instance, consider the surface depicted on the left in Figure 4.11, as an embedding of the closed square into \mathbb{R}^3 , with the third coordinate axis aligned with the right vertical closed interval. That is an apparently reasonable

embedding of a manifold with boundary, but it is not tame: the ambient standard projection $\mathbb{R}^3 \rightarrow \mathbb{R}^2$, when restricted to the image of the embedding, exhibits an intrinsically unconstructible entrance path convergence structure, which no amount of refinement can eliminate.

Another subtle failure of tameness can occur when two embeddings, each of which is itself tame, exhibit a non-local interaction that is globally untame. In Figure 5.7, we depict such an embedding of two disconnected stratified intervals. Each of the two intervals is tamely embedded, a bit like the left case in Figure 5.6; however, the projection of the joint embedding to \mathbb{R}^2 has infinitely many intersection points, and so cannot be refined by a mesh. Note that it is possible to slightly perturb the embedding to one that is in generic position with respect to the projection, and is then in fact tame. \square

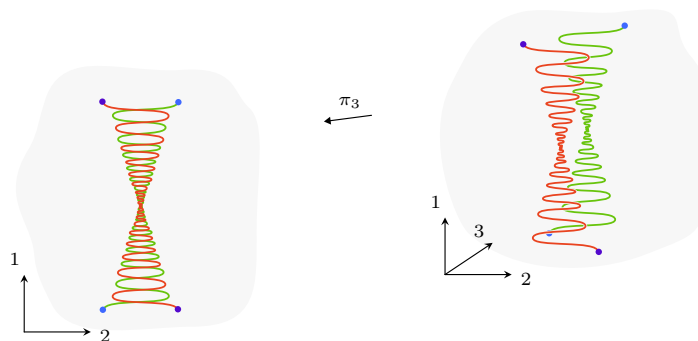

FIGURE 5.7. Nonlocal untameness.

REMARK 5.1.12 (Tameness and triangulability). Because meshes are in particular cellular stratifications, any tame embedding of a compact manifold has triangulable image (and so in particular the manifold is triangulable). Thus an untriangulable compact manifold (for instance the E_8 4-manifold [Fre82]) admits no tame embedding into euclidean space whatsoever. \square

REMARK 5.1.13 (Tame submersions). Morse functions are a class of especially well-behaved maps from manifolds to 1-dimensional euclidean space; these maps are typically of negative codimension. ‘Higher Morse functions’ ought to be a class of suitably and especially well-behaved maps from manifolds to n -dimensional euclidean space. Tame embeddings provide a precisely defined such class of maps in the case of *zero or positive codimension maps*. However, we can just as well handle the case of *negative codimension maps*, as follows. An **n -tame submersion** of a stratified space (W, g) is a map $\kappa : W \rightarrow \mathbb{R}^n$, that lifts along the projection $\mathbb{R}^n \times \mathbb{R}^k \rightarrow \mathbb{R}^n$ to an $(n+k)$ -tame embedding $\iota : W \hookrightarrow \mathbb{R}^{n+k}$. The notion of tame submersion is a robust higher analog of Morse functions for both unstratified and stratified manifolds. \square

REMARK 5.1.14 (Tame immersions). Of course, classically, immersions are a natural and rewarding generalization of embeddings. One may informally consider the notion of immersion as obtained from the notion of embedding by allowing discrete (rather than singleton or empty) fibers; more formally, one may characterize an immersion as a local submersion onto its image, again with discrete fibers. In the tame context, a suitable definition is obtained as follows. An n -**tame immersion** of a stratified space (W, g) is an n -tame submersion $\kappa : W \rightarrow \mathbb{R}^n$ with discrete fibers. For instance, a 2-tame immersion of the circle is obtained by composing the middle 3-tame embedding from Figure 5.5 with the projection $\pi_3 : \mathbb{R}^3 \rightarrow \mathbb{R}^2$; the image is the subspace depicted on the right in Figure 5.3. \square

In considering the above notions and terminology of tame submersion and tame immersion, one should keep in mind that the adjectives *framed* and *stratified* are implicit throughout; in particular, tame submersions are actually stratified topological submersions, after a suitable refinement whose existence is ensured by tameness.

Recall from Definition 4.1.86 that, for subspaces $Z \subset \mathbb{R}^n$ and $Z' \subset \mathbb{R}^n$, a map $F : Z \rightarrow Z'$ is framed if it descends along the projections $\pi_{>i} = \pi_{i+1} \circ \cdots \circ \pi_{n-1} \circ \pi_n : \mathbb{R}^n \rightarrow \mathbb{R}^i$ to maps $F_i : \pi_{>i}(Z) \rightarrow \pi_{>i}(Z')$. That notion provides a notion of framed maps of tame stratifications and tame embeddings, as follows.

TERMINOLOGY 5.1.15 (Framed maps of tame stratifications). Given n -tame stratifications (Z, f) and (Z', f') , a **framed map of tame stratifications** (also simply a ‘framed stratified map’) $F : (Z, f) \rightarrow (Z', f')$ is a stratified map, whose underlying map of spaces $Z \rightarrow Z'$ is framed. \square

TERMINOLOGY 5.1.16 (Framed maps of tame embeddings). Given n -tame embeddings $\iota : (W, g) \hookrightarrow \mathbb{R}^n$ and $\iota' : (W', g') \hookrightarrow \mathbb{R}^n$, a **framed map of tame embeddings** (also called again a ‘framed stratified map’) $F : \iota \rightarrow \iota'$ is a framed map $Z \rightarrow Z'$ of tame open neighborhoods $Z \supset \iota(W)$ and $Z' \supset \iota'(W')$, which restricts to a stratified map $\iota(W, g) \rightarrow \iota'(W', g')$. \square

TERMINOLOGY 5.1.17 (Framed stratified homeomorphisms). A ‘framed stratified homeomorphism of tame stratifications’ is a framed stratified map that is also a stratified homeomorphism. Similarly a ‘framed stratified homeomorphism of tame embeddings’ is a framed stratified map $\iota \rightarrow \iota'$ whose map of tame open neighborhoods is a homeomorphism $Z \cong Z'$ and whose restriction is a stratified homeomorphism $\iota(W, g) \cong \iota'(W', g')$. \square

EXAMPLE 5.1.18 (Framed stratified homeomorphism). In Figure 5.8, we depict a framed stratified homeomorphism F between two 2-tame embeddings of the circle. The framed map is between the indicated tame open neighborhoods Z and Z' , and factors through the projections $\pi_1 : \mathbb{R}^2 \rightarrow \mathbb{R}^1$

by a map F_1 , as required. (Of course the map of tame open neighborhoods is itself an example of a framed stratified homeomorphism of 2-tame stratifications.) —

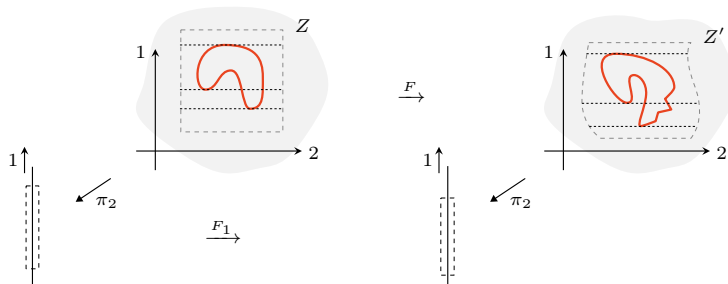

FIGURE 5.8. Framed stratified homeomorphism.

EXAMPLE 5.1.19 (Non-framed stratified homeomorphism). In Figure 5.9, by contrast, we depict a stratified homeomorphism of two 2-tame embeddings of the circle, which though is not a framed map. —

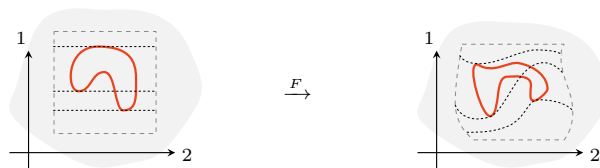

FIGURE 5.9. Non-framed stratified homeomorphism.

EXAMPLE 5.1.20 (Framed stratified map). In Figure 5.10, we depict a framed map of 3-tame embeddings, from an embedding of the 2-disc to an embedding of the thrice-punctured 2-sphere. This framed map is not a stratified homeomorphism, but it is a framed stratified homeomorphism onto its image, and so is in that sense a ‘framed substratification’. —

5.1.2. Overview of the classification. Tame stratifications (and similarly tame embeddings) are defined as purely stratified topological structures, satisfying the condition of admitting a mesh refinement. We know that meshes are combinatorially classifiable (by trusses), but a tame stratification does not come equipped with any preferred refining mesh; it is therefore quite unexpected that, as we will prove, tame stratifications nevertheless also permit a combinatorial classification. At root such a classification is possible because there will turn out to be a unique *coarsest* mesh refining a given tame stratification.³⁹ An intricate discussion of joins of mesh stratifications,

³⁹Contrast, for instance, the situation of triangulable manifolds, which also have, by assumption, combinatorializable refinements; but there is certainly no unique coarsest triangulation of a manifold, and triangulable manifolds are altogether hopelessly not combinatorially classifiable.

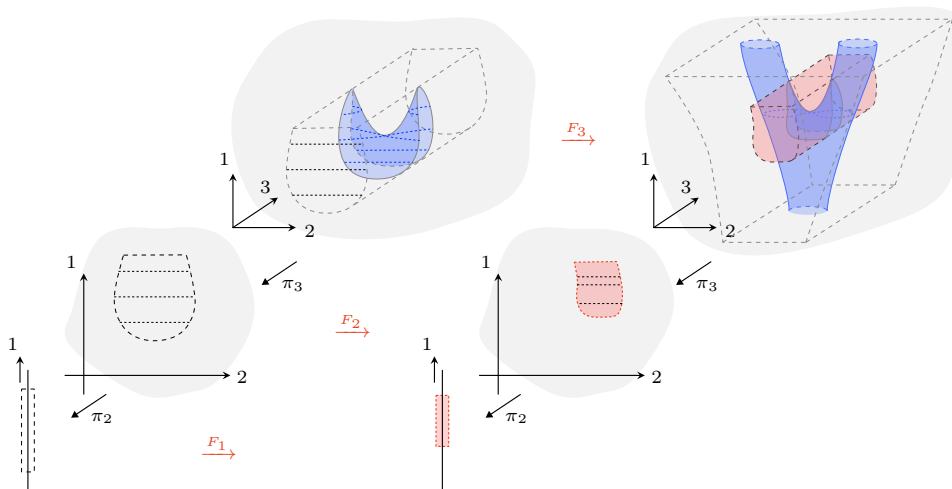

FIGURE 5.10. A framed substratification.

and the consequent exhibition of coarsest refining meshes, will occupy all of Section 5.2; the resulting classification of tame stratifications will be detailed and established in Section 5.3.1.

For a given tame stratification, there is a collection of refining meshes, each of which has its combinatorial truss counterpart; to identify the trusses corresponding to these refining meshes, we will need to encode the given stratification as a combinatorial structure on the fundamental trusses of those meshes. That encoding is achieved by the notion of stratified trusses, as follows. Recall from Definition 2.3.6 that a labeled n -truss has a functor from the total poset T_n to a labeling category. Regarding that poset as a topological space via its specialization topology (see Convention B.1.1), the labeling functor may itself be the characteristic map of a topological stratification (see Definition B.1.19 and Remark B.1.28).

DEFINITION 5.1.21 (Stratified n -trusses). A **stratified n -truss** is a labeled n -truss T , whose labeling lbl_T is the characteristic map of a stratification of the total poset T_n of the truss. —

The correspondence between n -meshes and n -trusses extends to a correspondence between n -meshes refining tame stratifications and n -trusses equipped with stratifications. Specifically, given an n -mesh M with a coarsening $\gamma : M \rightarrow f$ to a tame stratification f , the corresponding stratified n -truss is the fundamental n -truss $\mathbb{I}_T M$ together with the labeling $\mathbb{I}\gamma : \mathbb{I}M_n \rightarrow \mathbb{I}f$ by the fundamental poset map of the coarsening.

Any stratified n -truss so obtained from a refining n -mesh is a combinatorial encoding of a tame stratification. However, to obtain a unique combinatorial representative, we concentrate on those stratified trusses that do not admit any further truss coarsening that is compatible with the given stratification; such stratified trusses will correspond to the aforementioned

coarsest refining meshes. These uncoarsenable stratified trusses are called ‘normalized’ and are defined as follows.

DEFINITION 5.1.22 (Normalized stratified n -trusses). A stratified n -truss T is **normalized** when any label-preserving truss coarsening $T \rightarrow S$ is the identity. —

The main result of this chapter is the combinatorial classification of tame stratifications by their correspondence with normalized stratified trusses.

THEOREM 5.1.23 (Classification of tame stratifications). *Framed stratified homeomorphism classes of n -tame stratifications correspond bijectively with isomorphism classes of normalized stratified n -trusses.*

The stated correspondence takes a tame stratification to the fundamental stratified truss of its coarsest refining mesh. The proof of this result therefore hinges on the existence of such a coarsest mesh. That existence will follow in turn from the following crucial property of meshes: given any two meshes with the same support, there is a finest mutual coarsening mesh, which we call the *mesh join*.⁴⁰ As a tower of stratified bundles, the mesh join is simply the stage-wise join (in the lattice of stratifications and their coarsenings) of the two stratifications; technical attention is required merely to verify that the join is indeed again a mesh.

REMARK 5.1.24 (The case of tame embeddings). There is an analogous classification for tame embeddings: framed stratified homeomorphism classes of n -tame embeddings correspond to isomorphism classes of normalized, ambient stratified open n -trusses. This result is also developed in Section 5.3.1 and established as Theorem 5.3.33.⁴¹ —

5.1.3. Preview of applications. The classification of tame stratifications has several noteworthy consequences, which we group into those concerning *polyhedrality* and those concerning *computability*. The polyhedrality applications will be elaborated and established in Section 5.3.2, and the computability applications will be detailed and derived in Section 5.3.3.

A polyhedron is the image in euclidean space of a linear realization of a finite simplicial complex; it has a ‘simplicial stratification’ by the open simplices of the realized complex. A polyhedral stratification is a constructible substratification of a coarsening of a simplicial stratification of a polyhedron. Most immediately, the classification of tame stratifications implies that any closed or open tame stratification is framed stratified homeomorphic to a

⁴⁰Again we may contrast the situation of triangulations: two triangulations almost never have a mutual coarsening triangulation, even less so a distinguished finest such.

⁴¹In an under-appreciated thread of influence, C. D. Ridenhour was reading Freedman’s landmark 1982 paper on the topology of four-dimensional manifolds, when, stunned by the realization that the E_8 manifold was untriangulable (cf. Remark 5.1.12), he dashed off the lyrics to the song that later became the lead single of *Apocalypse 91*, presciently titled, “Can’t Truss It”.

canonical polyhedral stratification (namely a stratified mesh realization of the corresponding normalized stratified truss).

COROLLARY 5.1.25 (Tame stratifications are polyhedral). *Any closed or open tame stratification is framed stratified homeomorphic to a polyhedral stratification.*

Since an ambiently tame stratification is a constructible substratification of an open tame stratification, it is also framed stratified homeomorphic to a polyhedral stratification (in fact, again a canonical one); thus any tame embedding is framed stratified homeomorphic to one with polyhedral stratified image. Conversely, polyhedral stratifications are always tame, as follows.

PROPOSITION 5.1.26 (Polyhedral stratifications are tame). *Any polyhedral stratification in \mathbb{R}^n is the stratified homeomorphic image of an n -tame embedding.*

Not only are (closed or open) tame stratifications framed stratified homeomorphic to polyhedral stratifications, but in this context, the notions of ‘framed stratified homeomorphism’ and of ‘framed stratified piecewise linear homeomorphism’ coincide. That result is another headline consequence of the classification of tame stratifications, as follows.

THEOREM 5.1.27 (Framed Hauptvermutung). *Any framed stratified homeomorphism between polyhedral stratifications is (framed stratified) homotopic to a framed stratified piecewise linear homeomorphism.*

That homotopy to a PL homeomorphism is in fact unique up to contractible choice. Of course this framed Hauptvermutung is startling because the classical, unframed analog fails: there are bounded polyhedral stratifications that are topologically stratified homeomorphic but not piecewise linearly stratified homeomorphic.

REMARK 5.1.28 (Framed vs. framed PL vs. PL). We may summarize, as follows, the relationships established between framed, framed piecewise linear, and purely piecewise linear phenomena. The functor from (say, closed) tame polyhedral stratifications (i.e. polyhedral stratifications considered with framed stratified piecewise linear maps) to (closed) tame stratifications is surjective on equivalence classes, by [Corollary 5.1.25](#); furthermore, that functor is injective on equivalence classes by [Theorem 5.1.27](#).

The functor from tame polyhedral stratifications to polyhedral stratifications is surjective on equivalence classes, by [Proposition 5.1.26](#). However, that functor is far from being injective on equivalence classes, because framed stratified piecewise linear homeomorphism is a much finer equivalence relation than (unframed) stratified piecewise linear homeomorphism. —

Having considered the polyhedrality of tame stratifications, we turn to the computability of tame stratifications.

Recall that any tame stratification has an associated unique coarsest refining mesh, and of course its combinatorial counterpart, a normalized stratified truss. It is by no means clear that there is any systematic way of identifying that coarsest mesh, or equivalently its normalized truss. But in fact we will prove that *stratified truss coarsening is confluent*, in the sense that any maximal chain of coarsenings of a stratified truss ends in its normalized truss. Consequently, at worst, any brute or greedy coarsening algorithm will yield the normalized truss, and therefore the corresponding coarsest mesh. (In the following statement, and henceforth whenever discussing algorithmic properties of tame stratifications, we take as given some refining mesh witnessing the tameness of the tame stratification; in particular no claim is made about the algorithmicity of determining tameness itself.)

COROLLARY 5.1.29 (Canonical coarsest mesh refinements are computable). *Given a tame stratification, one can algorithmically determine its coarsest refining mesh.*

In fact we will sketch an efficient algorithm for stratified n -truss normalization (and thus stratified mesh coarsening), that proceeds by normalizing the 1-truss fibers over the projected $(n - 1)$ -truss, iteratively in decreasing depth within the $(n - 1)$ -stage truss poset, and then inductively proceeding down the truss tower using stratifications induced by increasingly expressive classifying functors.

Having established that we can compute the coarsest refining meshes of tame stratifications, and observing that the existence of a stratified isomorphism of corresponding normalized stratified trusses is certainly algorithmically determinable, we will find that equivalence of tame stratifications is decidable, as follows.

THEOREM 5.1.30 (Framed stratified homeomorphism of tame stratifications is decidable). *Given two tame stratifications, one can algorithmically decide whether they are framed stratified homeomorphic.*

Of course, the classical, unframed analog of this result, whether stratified or unstratified, fails wildly: homeomorphism of (even combinatorially presented) topological spaces is algorithmically undecidable [Mar58].

The computable classification of tame stratifications enables the fundamental construction of a *dual stratification* of any tame stratification: from a tame stratification, determine its coarsest refining mesh, take the associated normalized stratified truss, form the dual stratified truss (consisting of the dual truss and the stratification given by the opposite labeling functor), and finally build the stratified mesh realization. The confluence of stratified truss coarsenings dualizes to the confluence of stratified truss degeneracies; consequently any tame stratification has a computable, unique maximally degenerated quotient stratification.

The preceding computability results concern n -tame stratifications, so in particular stratifications of subspaces of n -dimensional euclidean space.

We may drastically extend the scope of these results by considering n -framed regular cell complexes, that need not embed in \mathbb{R}^n but that merely admit a framed realization to \mathbb{R}^n . (As in [Terminology 1.3.37](#), a map is a framed realization when it is linear on each simplex, respects the frame vectors, and is an embedding on each cell.) Recall from [Definition 1.3.74](#) that that we refer to such complexes as *n -directed acyclic graphs*.

The join stratification techniques that enabled us to construct a coarsest mesh refining a given tame stratification, generalize to establish the existence and computability of a unique *coarsest cell structure* of any given n -directed acyclic graph. (Yet again, note the sharp contrast to the classical case: a regular cell complex typically has numerous distinct and incompatible coarsest cell structures.) As the computability of the coarsest refining mesh of a tame stratification ensured the decidability of equivalence of tame stratifications, similarly the computability of the coarsest cell structure leads to a corresponding decidability result for n -directed acyclic graphs, as follows.

THEOREM 5.1.31 (Framed homeomorphism of n -DAGs is decidable). *Given two n -directed acyclic graphs, one can algorithmically decide whether they are framed homeomorphic.*

The coarsest cell structure, and the decidability of framed homeomorphism, is useful even for complexes that do embed in euclidean space. In particular, tame embeddings inherit framed cell structures from the coarsest refining meshes of their tame neighborhoods, and those cell structures admit a further, often substantial, coarsening simplicification to their coarsest cell structures as framed complexes.

5.2. Coarsest meshes

We have promoted tame stratifications as a tractable class of stratifications, which is both general enough to capture all finitary topological structures and which admits a decidable, combinatorial classification. Leaving the generality for now as a mix of analytic stipulation and informed faith, we proceed with considering the combinatorial classifiability. Recall that by definition a tame stratification admits a mesh refinement; and of course that refining mesh is combinatorially classified by its fundamental truss. The issue, a priori, is that a given tame stratification certainly has multiple distinct and seemingly incompatible refining meshes. Indeed, given two such meshes, some strata from the first will be in the second, some will not; some strata from the second will be in the first, some will not; and distinct strata of the two can intersect and interact in rather uncontrolled ways. It is therefore a striking and crucial structural property of meshes that any two have a canonical common coarsening called the *mesh join*. That join is obtained, at each mesh stage, by merging strata of the two meshes whenever they intersect; the difficulty will be seeing that the resulting tower of maps is suitably stratified, continuous, and constructible as to be itself a mesh.

Fix again a tame stratification, and consider the collection of all its refining meshes. Since meshes are finite stratifications, from any given refining mesh, there is at most a finite length chain of coarsenings in the collection. The end of that chain has the feature that it is coarser than any refining mesh whatsoever: otherwise the mesh join with a non-finer mesh would produce a further coarsening, extending the chain. That procedure therefore produces a canonical *coarsest refining mesh* of the tame stratification. The fundamental truss of the coarsest refining mesh provides a combinatorial substrate, upon which the later classification of tame stratifications will rely. An example of a tame stratification and its coarsest refining mesh is illustrated in Figure 5.11. The stratification, on the right, is of a triangular prism, with two bulk strata and a single smooth surface stratum that has a cusp singularity for the top projection. The coarsest refining mesh, on the left, isolates the cusp as a point stratum, and the two folds as line strata, along with other line and surface strata minimally encoding the geometry of the singularity and all its projections.

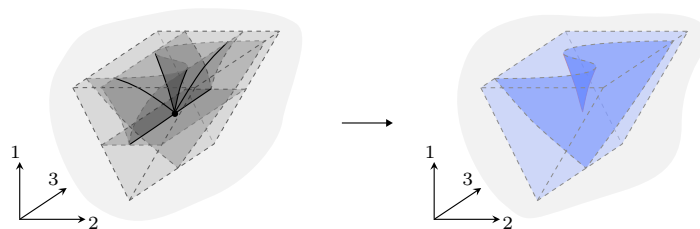

FIGURE 5.11. A tame stratification and its coarsest refining mesh.

OUTLINE. In Section 5.2.1, we introduce joins of stratifications as the finest mutual coarsening, define mesh joins as stage-wise stratification joins, and prove that the mesh join is indeed a mesh. In Section 5.2.2, we define the coarsest refining mesh of a tame stratification as a refining mesh that coarsens all others, and the minimal coarsest refining mesh of a tame embedding as one that cannot be coarsened or constructibly shrunk; we establish that both coarsest and minimal coarsest meshes exist and are unique. Finally, in Section 5.2.3, we provide a variety of examples of coarsest and minimal coarsest meshes of tame stratifications and tame embeddings, respectively.

5.2.1. Mesh joins.

SYNOPSIS. We define the join of two stratifications as their finest mutual coarsening, and introduce joins of meshes and joins of mesh bundles as towers of join stratifications. We then prove the key lemma that mesh joins are themselves meshes, inductively from the join stability of 1-mesh bundles, which itself follows using auxiliary results concerning the projections and bounds of joined strata.

5.2.1.1. The definition of mesh joins. The join of two stratifications of the same space is their finest mutual coarsening. That coarsening may be, however, only a *prestratification*; recall that prestratifications, unlike stratifications, allow cycles in their formal entrance path relation (see Terminology B.1.7).

DEFINITION 5.2.1 (Joins of stratifications). Given stratifications f and g of a space X , the **join** $f \vee g$ is the prestratification of X , that coarsens both f and g , and such that, for any other prestratification h coarsening both f and g , there is a coarsening from $f \vee g$ to h . —

CONSTRUCTION 5.2.2 (Joins of stratifications). Given a space X and stratifications (X, f) and (X, g) , let \sim denote the transitive closure of the relation, on the union of the set of strata of f and the set of strata of g , given by

$$s \sim t \iff (s \cap t \neq \emptyset) .$$

The join $f \vee g$ is the prestratification of X whose strata are the nonempty connected subspaces $\bigcup_{s \in \mathfrak{s}} s$, where \mathfrak{s} ranges over the equivalence classes of the relation \sim . —

REMARK 5.2.3 (Joins as pushouts). The joins of (pre)stratifications (X, f) and (X, g) may also be characterized as the following pushout in the category of prestratifications:

$$\begin{array}{ccc} \text{discr}(X) & \longrightarrow & (X, f) \\ \downarrow & & \downarrow \\ (X, g) & \longrightarrow & (X, f \vee g) \end{array}$$

Here $\text{discr}(X)$ is the discrete stratification (see Terminology B.1.17).

Note that this pushout is preserved when taking fundamental preorders. Thus in particular, the pushout of a span of posets (in the category of preorders) need not be a poset (but merely a preorder). \square

EXAMPLE 5.2.4 (Joins of stratifications). In Figure 5.12, we depict two examples of a join of stratifications; the first case joins two stratifications of the closed pentagon, while the second case joins two stratifications of the closed rectangle. Note that in the second case, the join is only a prestratification, and its fundamental poset merely a preorder. \square

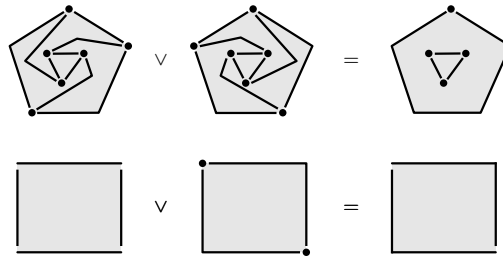

FIGURE 5.12. Joins of stratifications.

NOTATION 5.2.5 (Equivalence classes and strata in joins). Given stratifications (X, f) and (X, g) , we will abuse notation and denote the strata of their join $f \vee g$ by, for instance, $\mathfrak{s} := \bigcup_{s \in \mathfrak{s}} s$; that is, we denote by \mathfrak{s} both an equivalence class of strata of f and g , and a stratum of the join $f \vee g$. Thus we may write $r \in \mathfrak{s}$, where r is a stratum, to mean a member of the equivalence class \mathfrak{s} . And we may write $x \in \mathfrak{s}$, where x is a point, to mean a point in the stratum \mathfrak{s} .

Further, we will denote by \mathfrak{s}_f the subset of the equivalence class \mathfrak{s} consisting of strata of f , and by \mathfrak{s}_g the subset of the equivalence class consisting of strata of g . \square

In constructing the joins of meshes and of mesh bundles, we will want and need to restrict attention to sufficiently nice base stratifications; we codify that presumption as follows.

TERMINOLOGY 5.2.6 (Sufficiently nice stratifications). A stratification is ‘sufficiently nice’ when it is finite, frontier-constructible, and cellulable. \square

PROPOSITION 5.2.7 (Joins of sufficiently nice stratifications). *Given sufficiently nice stratifications (X, f) and (X, f') , their join $(X, f \vee f')$ is itself a sufficiently nice stratification.*

PROOF. Finiteness and cellulability are both preserved under coarsening, so those properties immediately propagate to the join. To see that the join is also frontier-constructible, argue as follows. Suppose the closure of a stratum \mathfrak{s} intersects the stratum r , but does not contain it. Then there is a stratum

$r \in \mathfrak{r}$ which itself intersects the closure of \mathfrak{s} but is not contained in it. Assume $r \in \mathfrak{r}_f$; then since \mathfrak{s} is the union of the strata in \mathfrak{s}_f , there is an $s \in \mathfrak{s}_f$ whose closure intersects r but does not contain it, contradicting the frontier constructibility of f . \square

OBSERVATION 5.2.8 (Joins of stratified maps). Given stratified maps $F : (X, f) \rightarrow (X', f')$ and $G : (X, g) \rightarrow (X', g')$ that are identical as maps of underlying spaces $X \rightarrow X'$, there is another stratified map

$$F \vee G : (X, f \vee g) \rightarrow (X', f' \vee g')$$

with the same underlying map of spaces. We call it the join of the maps F and G . \square

We will be primarily interested in the joins of meshes and their bundles. In the construction of those joins, it will be convenient to consider meshes as subspaces of euclidean space, rather than as abstract spaces equipped with an n -realization into euclidean space.

CONVENTION 5.2.9 (Keep n -realizations implicit). Given an n -mesh M with n -realization γ (as described in [Construction 4.1.70](#)), we will usually identify the i -th stage space M_i with its image under the map $\gamma_i : M_i \hookrightarrow \mathbb{R}^i$, and so elide the maps γ_i entirely. Similarly given an n -mesh bundle p over a base (B, g) , we identify the space M_i with its image in $B \times \mathbb{R}^i$ and suppress the realization maps $\gamma_i : M_i \hookrightarrow B \times \mathbb{R}^i$ (from [Construction 4.1.77](#)). \square

DEFINITION 5.2.10 (Mesh joins). Consider two n -meshes M and M' consisting, respectively, of the 1-mesh bundles $p_i : (M_i, f_i) \rightarrow (M_{i-1}, f_{i-1})$ and $p'_i : (M'_i, f'_i) \rightarrow (M'_{i-1}, f'_{i-1})$; assume these meshes have identical support $M_n = M'_n \subset \mathbb{R}^n$, and so identical projected support $M_i = M'_i \subset \mathbb{R}^i$. The **mesh join** $M \vee M'$ is the tower of stratified maps $p_i \vee p'_i : (M_i, f_i \vee f'_i) \rightarrow (M_{i-1}, f_{i-1} \vee f'_{i-1})$. \square

DEFINITION 5.2.11 (Join of mesh bundles). Similarly, consider two n -mesh bundles p and p' , consisting of the 1-mesh bundles $p_i : (M_i, f_i) \rightarrow (M_{i-1}, f_{i-1})$ and $p'_i : (M'_i, f'_i) \rightarrow (M'_{i-1}, f'_{i-1})$; assume these have the same base and identical support. The **join of mesh bundles** $p \vee p'$ is again the tower $p_i \vee p'_i$. \square

When the join of mesh bundles is in fact a mesh bundle, we refer to it also as the ‘mesh bundle join’.

EXAMPLE 5.2.12 (Mesh joins). In [Figure 5.13](#), we depict the mesh join of two open 2-meshes (represented via their realizations in \mathbb{R}^2). Note that the mesh join is again a 2-mesh. \square

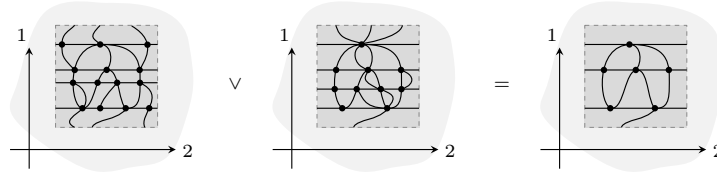

FIGURE 5.13. The join of two open meshes.

5.2.1.2. * The mesh join lemma. The crucial claim, as noted in the preceding example, is that joins of meshes are themselves meshes; the proof of that claim will occupy this section.

KEY LEMMA 5.2.13 (Join stability of meshes). *Given n -meshes M and M' with identical support, their mesh join $M \vee M'$ is itself an n -mesh.*

PROOF. By induction in n , we may assume the mesh join $M_{<n} \vee M'_{<n}$ of the $(n - 1)$ -truncations $M_{<n}$ and $M'_{<n}$ is an $(n - 1)$ -mesh. For the inductive step, we need to show that the stratified map $p_n \vee p'_n : f_n \vee f'_n \rightarrow f_{n-1} \vee f'_{n-1}$ is a 1-mesh bundle. The next **Lemma 5.2.14** establishes this is the case, provided that f_{n-1} and f'_{n-1} are sufficiently nice stratifications, in the sense of **Terminology 5.2.6**, and that $f_{n-1} \vee f'_{n-1}$ is a cellular stratification. That sufficient niceness is ensured inductively using **Observation 4.1.66**, **Observation 4.1.67**, and **Proposition 4.1.63**. The cellularity of $f_{n-1} \vee f'_{n-1}$ is given by **Observation 4.1.75**, since the join $M_{<n} \vee M'_{<n}$ is an $(n - 1)$ -mesh by induction. \square

LEMMA 5.2.14 (Join stability of 1-mesh bundles). *Let (B, g) and (B, g') be sufficiently nice stratifications. Consider 1-mesh bundles $p : (M, f) \rightarrow (B, g)$ and $p' : (M, f') \rightarrow (B, g')$ with the same underlying map of spaces, and their join $p \vee p' : (M, f \vee f') \rightarrow (B, g \vee g')$.*

- (1) *The join $p \vee p'$ is a categorical 1-mesh bundle.*
- (2) *When $g \vee g'$ is cellular, the join $p \vee p'$ is a 1-mesh bundle.*

EXAMPLE 5.2.15 (A categorical bundle join). As described in the previous lemma, the join of 1-mesh bundles need only be a categorical 1-mesh bundle, if the base stratification join is not cellular. In **Figure 5.14**, we illustrate this situation, of a categorical mesh bundle join over a non-cellular base. $\text{—}\square$

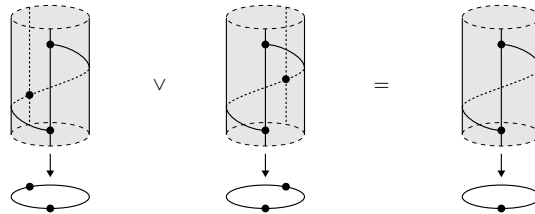

FIGURE 5.14. A categorical 1-mesh bundle as a join.

Working toward the proof of this lemma, we first establish the following two auxiliary results. (Note again that the stratified maps p and p' and $p \vee p'$ all have the same underlying map of spaces; for brevity, we typically and abusively refer to that map of spaces simply as p , no matter the stratification under consideration.)

- › In Lemma 5.2.16, we show that for any stratum s in $f \vee f'$, the image $p(s)$ is exactly a stratum r in $g \vee g'$.
- › In Lemma 5.2.18, we show that for each stratum s in $f \vee f'$, there are continuous sections $\hat{\gamma}_s^\pm : p(s) \rightarrow p(s) \times \mathbb{R}$ that fiberwise bound s from above and below.

LEMMA 5.2.16 (Joined strata project onto joined strata). *For 1-mesh bundles $p : (M, f) \rightarrow (B, g)$ and $p' : (M, f') \rightarrow (B, g')$ with identical underlying maps of spaces, the image under $p \vee p'$ of any stratum s of the join $f \vee f'$ is exactly a stratum in the join $g \vee g'$.*

PROOF. Since the join $p \vee p'$ is a stratified map, the image $p(s)$ is certainly contained in some stratum r of $g \vee g'$. Since p is a 1-mesh bundle, the images of strata of f are exactly strata of g . Recall from Observation 5.2.8 the class r_g of strata of g inside the stratum r of $g \vee g'$. Consider the subclass r_p^s of r_g consisting of the images of strata in s_f . The union of strata in r_p^s is exactly $p(s)$, and of course the union of strata in r_g is exactly r . It suffices then to show that $r_p^s = r_g$.

Suppose, for contradiction, that $r_p^s \subsetneq r_g$. Then we can find a stratum r' in the class $r_{g'}$ that intersects both r_p^s and $r_g \setminus r_p^s$. Pick a stratum r in r_p^s that intersects r' . By the definition of r_p^s , there is a stratum s in the class s_f projecting to r . Since r intersects r' , there is at least one stratum s' in f' that projects to r' and intersects s . But r' intersects $r_g \setminus r_p^s$ and so some point of s' projects into a stratum of $r_g \setminus r_p^s$; the stratum of s_f containing that point projects onto that stratum of $r_g \setminus r_p^s$, a contradiction. \square

Recall from Notation 4.1.15, Notation 4.1.25, and Definition 4.1.28 that 1-mesh bundles must have continuous upper and lower realization bounds. In the process of showing that joins of 1-mesh bundles are 1-mesh bundles, we will need to know that every stratum similarly has continuous upper and lower bounds, in the following sense.

NOTATION 5.2.17 (Lower and upper fiber bounds). For a subspace $s \subset B \times \mathbb{R}$ and a point $x \in B$ in the image of s under the projection $\pi : B \times \mathbb{R} \rightarrow B$, the ‘lower and upper fiber bounds’ $\hat{\gamma}_s^-(x)$ and $\hat{\gamma}_s^+(x)$ are the lower and upper bounds of the fiber $s_x := s \cap \pi^{-1}(x) \subset \mathbb{R}$. —

By Lemma 5.2.16, the image of a stratum s of the join $f \vee f'$ is a stratum of the base join $g \vee g'$. Therefore the fiber bounds are well defined over that whole base stratum, and in fact they are continuous, as follows.

LEMMA 5.2.18 (Joined strata are bounded by continuous sections). *Consider 1-mesh bundles $p : (M, f) \rightarrow (B, g)$ and $p' : (M, f') \rightarrow (B, g')$ over*

sufficiently nice base stratifications. For any stratum \mathfrak{s} of the join $f \vee f'$, the functions $\hat{\gamma}_{\mathfrak{s}}^{\pm} : p(\mathfrak{s}) \rightarrow p(\mathfrak{s}) \times \mathbb{R}$, mapping the base point x to the lower and upper fiber bounds $\hat{\gamma}_{\mathfrak{s}}^{\pm}(x)$, are continuous.

PROOF. Abbreviate $\mathfrak{r} = p(\mathfrak{s})$. We begin with the following two observations.

(1) For each base point $x \in \mathfrak{r}$, the fiber bound $\hat{\gamma}_{\mathfrak{s}}^{\pm}(x) \in \mathfrak{r} \times \mathbb{R}$ is either the realization bound $\gamma^{\pm}(x)$ of the bundle p (or equivalently of p') at x , or it is a point in singular strata of both f and f' . Indeed, it cannot be a point in a regular stratum of either f or f' , since regular strata intersect fibers of the projection $B \times \mathbb{R} \rightarrow B$ in open intervals.

(2) For each stratum v in the equivalence class \mathfrak{r} , the map $\hat{\gamma}_{\mathfrak{s}}^{\pm}$ restricts to a continuous map on v . Indeed, assume $v \in \mathfrak{r}_g$ (or similarly $v \in \mathfrak{r}_{g'}$). Then the intersection $\mathfrak{s} \cap p^{-1}(v)$ is exactly a union of strata in f , namely those strata $\mathfrak{s}_v \subset \mathfrak{s}$ that lie over v . By the previous observation, the image $\hat{\gamma}_{\mathfrak{s}}^{\pm}(v)$ of the fiber bound $\hat{\gamma}_{\mathfrak{s}}^{\pm} : v \rightarrow v \times \mathbb{R}$ is therefore either equal to the realization bound $\gamma^{\pm}(v)$ or to some singular stratum in f lying over the stratum v . In either case, the function $\hat{\gamma}_{\mathfrak{s}}^{\pm}$ is continuous on that stratum v .

If a stratum $u \in \mathfrak{r}$ contains a point x at which $\hat{\gamma}_{\mathfrak{s}}^{\pm}$ is not continuous (that is, $\hat{\gamma}_{\mathfrak{s}}^{\pm}$ is not continuous in any neighborhood of x inside the stratum \mathfrak{r}), we will say that u is ‘bad’; otherwise, we say that u is ‘good’. Note that by the second observation above, discontinuities cannot occur within a stratum, and so bad strata cannot be *minimal* elements in \mathfrak{r}_g (or $\mathfrak{r}_{g'}$), where \mathfrak{r}_g (or $\mathfrak{r}_{g'}$) is considered as a full subposet of $\mathbb{P}(g)$ (or $\mathbb{P}(g')$). In particular, there exist at least some good strata, namely the minimal elements in \mathfrak{r}_g and $\mathfrak{r}_{g'}$.

We now show that, given a bad stratum u , the map $\hat{\gamma}_{\mathfrak{s}}^{\pm}$ is, in fact, discontinuous at *all* points of u . Assume $u \in \mathfrak{r}_g$ is bad with a discontinuity at $x \in u$ (the argument is the same when $u \in \mathfrak{r}_{g'}$). By the finiteness of the base stratification g , we can pick a stratum \tilde{u} adjacent to u , such that $\hat{\gamma}_{\mathfrak{s}}^{\pm}$ is discontinuous at x when restricted to the union $u \cup \tilde{u}$. As mentioned above, the subspace $\hat{\gamma}_{\mathfrak{s}}^{\pm}(\tilde{u})$ is either a singular stratum in f or is the realization bound $\gamma^{\pm}(\tilde{u})$. It follows, by constructibility of the 1-mesh bundle $p : f \rightarrow g$ and by continuity of the bundle bounds γ^{\pm} , that either the closure of the image $\hat{\gamma}_{\mathfrak{s}}^{\pm}(\tilde{u})$ contains *all* or else *none* of the image $\hat{\gamma}_{\mathfrak{s}}^{\pm}(u)$. The latter case must hold, since the former would imply continuity at x (within $u \cup \tilde{u}$). By frontier-constructibility of g , the stratum \tilde{u} contains all of u in its closure, and thus $\hat{\gamma}_{\mathfrak{s}}^{\pm}$ is discontinuous at all points in u , as claimed.

To see finally that $\hat{\gamma}_{\mathfrak{s}}^{\pm}$ is continuous on all of the base stratum \mathfrak{r} , we argue by contradiction as follows. Assume a bad stratum u exists, and suppose $u \in \mathfrak{r}_g$ (again the argument is the same when $u \in \mathfrak{r}_{g'}$). Denote by $\mathfrak{r}_{g',1}^u$ the subclass of $\mathfrak{r}_{g'}$ consisting of strata that intersect u . Note all strata in $\mathfrak{r}_{g',1}^u$ are bad, since they each intersect u in at least one point. Moreover, the union of strata in $\mathfrak{r}_{g',1}^u$ *strictly* includes u and, since good strata exist, does not cover \mathfrak{r} . (The inclusion is strict since u is not already all of \mathfrak{r} , and the stratum \mathfrak{r} of the join $g \vee g'$ is by definition the transitive closure of the stratum intersection

relation.) Denote by $r_{g,1}^u$ the subclass of r_g consisting of strata that intersect $r_{g',1}^u$. Again, all strata in $r_{g,1}^u$ are bad and their union strictly includes the union of strata in $r_{g',1}^u$, but does not cover r . Denote by $r_{g',2}^u$ the subclass of $r_{g'}$ intersecting $r_{g,1}^u$. Repeating the argument in this way, we obtain a strictly increasing infinite sequence $r_{g',1}^u \subset r_{g',2}^u \subset r_{g',3}^u \subset \cdots \subset r_{g'}$; the existence of such a sequence contradicts the finiteness of the stratification g' . \square

We can now prove that the join of 1-mesh bundles is again a 1-mesh bundle.

PROOF OF LEMMA 5.2.14. We first verify that the join $p \vee p' : f \vee f' \rightarrow g \vee g'$ is a stratified bundle whose fibers are 1-meshes. Consider a stratum \mathfrak{s} of $f \vee f'$ lying over a stratum $r = p(\mathfrak{s})$ of $g \vee g'$. In the preceding proof, we observed that for each stratum $v \in r_g$ (or $v \in r_{g'}$), either $\hat{\gamma}_{\mathfrak{s}}^{\pm}(v) = \gamma^{\pm}(v)$ or else $\hat{\gamma}_{\mathfrak{s}}^{\pm}(v)$ is a singular stratum of f (or f' respectively). Because that image $\hat{\gamma}_{\mathfrak{s}}^{\pm}(v)$ being the realization bound (or being a singular stratum) propagates across strata intersections in the base, in fact either $\hat{\gamma}_{\mathfrak{s}}^{\pm}(r) = \gamma^{\pm}(r)$ or else $\hat{\gamma}_{\mathfrak{s}}^{\pm}(r)$ is both a union of singular strata of f and a union of singular strata of f' ; in the latter case, $\hat{\gamma}_{\mathfrak{s}}^{\pm}(r)$ is a stratum of $f \vee f'$.

It follows that either (1) $\hat{\gamma}_{\mathfrak{s}}^{-}(r)$ and $\hat{\gamma}_{\mathfrak{s}}^{+}(r)$ are disjoint, or (2) $\hat{\gamma}_{\mathfrak{s}}^{-}(r) = \hat{\gamma}_{\mathfrak{s}}^{+}(r)$. If (1) holds, then the stratum \mathfrak{s} is isomorphic to a product of the base stratum r and an open interval. If (2) holds, then the stratum \mathfrak{s} is a section of the bundle p over the stratum r . It follows, using the fiber bound continuity established in Lemma 5.2.18, that $p \vee p' : f \vee f' \rightarrow g \vee g'$ is stratified-locally trivial, and has 1-mesh fibers, as required.

The bundle certainly inherits its continuous realization bounds γ^{\pm} from p . It remains only to verify that the join $p \vee p' : f \vee f' \rightarrow g \vee g'$ is constructible. We first verify path-dependent constructibility, in the sense of Definition 4.1.41, or more precisely in the sense mentioned immediately after that remark. Consider an entrance path $\alpha : r \rightarrow u$ and a singular stratum \mathfrak{s} with $p(\mathfrak{s}) = r$. Define the lift entrance path $\beta : \mathfrak{s} \rightarrow v$ as follows: take $\beta|_{[0,1]}$ to lift $\alpha|_{[0,1]}$ along the homeomorphism $p : \mathfrak{s} \rightarrow r$, and set $\beta(1)$ to be the limit $\lim_{t \rightarrow 1} \beta(t)$. That this limit, and thus entrance path, exists, and that the target stratum v is singular, follows from the constructibility of f and f' . (Though the entrance path α need not be an entrance path in either g or g' , there is a sequence $\{t_i \in [0,1]\}$ converging to 1, and an entrance path $\tilde{\alpha} : \tilde{\mathfrak{s}} \rightarrow \tilde{r}$ of either g or g' with $\tilde{\alpha}(t_i) = \alpha(t_i)$; the lift of $\tilde{\alpha}$ exists, ensuring the lift of α exists.) That entrance path is uniquely determined by the bare topology of the fibers. Altogether then $p \vee p'$ is a categorical 1-mesh bundle.

Finally, consider the case when the base stratification join $g \vee g'$ is cellular, i.e. by definition a constructible substratification of a regular cell complex. Recall from Proposition 1.3.15 that regular cell complexes are stratified realizations of cellular posets. Thus Proposition 4.1.43 ensures that the join $p \vee p'$ is, in fact, a 1-mesh bundle. \square

That establishes the join stability of 1-mesh bundles; the join stability of n -meshes, as in Key Lemma 5.2.13, follows as previously discussed.

We briefly mention two further forms of join stability.

LEMMA 5.2.19 (Join stability for mesh bundles). *Let p and p' be n -mesh bundles over the same cellular base (B, g) and with the same support in $B \times \mathbb{R}^n$. The join $p \vee p'$ is itself an n -mesh bundle.*

The proof of Key Lemma 5.2.13 applies here, verbatim after replacing ‘meshes’ by ‘mesh bundles’.

It will be useful to consider joins in the situation where two meshes do not have identical support, but merely one support is contained in the other.

LEMMA 5.2.20 (Stability for relative mesh joins). *Let M and M' be n -meshes, such that the support Z of M is a subspace of the support of M' . Denote by $M'|_Z$ the tower of stratified maps obtained by restricting the tower M' to Z . The stage-wise join $M \vee (M'|_Z)$ is itself an n -mesh.*

We omit a detailed verification; the proof follows the same structure and ideas as that of Key Lemma 5.2.13, but requires additional care regarding strata of M' that only partially intersect the support Z of M .

5.2.2. The coarsest mesh constructions.

SYNOPSIS. We define the coarsest refining mesh of a tame stratification, as a mesh refinement that coarsens all other mesh refinements; using mesh joins, we prove that coarsest refining meshes always exist. We then define minimal coarsest refining meshes of tame embeddings, as refining meshes that cannot be coarsened and also cannot be shrunk to a constructible substratification; we show that minimal coarsest refining meshes also exist and are unique.

5.2.2.1. Coarsest refining meshes of tame stratifications. Equipped with mesh joins, we may barrel directly into a discussion of coarsest refining meshes.

TERMINOLOGY 5.2.21 (Meshes refining meshes). Given meshes M and N with the same support, we say that ‘ N refines M ’ or equivalently ‘ M coarsens N ’ if the identity map of the underlying support spaces is a mesh coarsening $N \rightarrow M$. —

DEFINITION 5.2.22 (Coarsest refining meshes). A **coarsest refining mesh** of an n -tame stratification (Z, f) is an n -mesh M refining (Z, f) , such that for any other n -mesh N refining (Z, f) , the mesh N also refines the mesh M . —

Of course, if a tame stratification has a coarsest refining mesh, it has a unique coarsest refining mesh. The fact that coarsest refining meshes always exist is a fundamental and indispensable feature of the theory of tame stratifications.

THEOREM 5.2.23 (Canonical meshes of tame stratifications). *Every n -tame stratification has a coarsest refining n -mesh.*

PROOF. Given any two n -meshes M and N , both refining the n -tame stratification (Z, f) , the mesh join $M \vee N$ (provided by Key Lemma 5.2.13) is another n -mesh refining (Z, f) , and $M \vee N$ coarsens both M and N . Since meshes are finite stratifications, any chain of mesh coarsenings must terminate. That termination is necessarily a coarsening of every mesh refining the tame stratification, providing a (unique) coarsest refining mesh, as required. \square

Illustrative examples of such coarsest refining meshes of tame stratifications will be given later in Figure 5.16, Figure 5.18, and Figure 5.20.

As one may expect, coarsest refining meshes are compatible with framed stratified homeomorphisms of tame stratifications, in the following sense. Recall from Observation 4.1.88 that mesh isomorphisms $F : M \cong N$ determine and are determined by framed stratified homeomorphisms $F_n : (M_n, f_n) \cong (N_n, g_n)$.

OBSERVATION 5.2.24 (Transporting meshes along homeomorphisms). Given a mesh M with support Z , and a framed homeomorphism $F : Z \rightarrow W$, there is a ‘pushforward mesh’ F_*M with support W , such that there is an n -mesh isomorphism $M \cong F_*M$ with top component having support map $F : Z \rightarrow W$.

Conversely, given a mesh N with support W , there is a ‘pullback mesh’ F^*N with support Z , such that there is an n -mesh isomorphism $F^*N \cong N$ with top component again having support map $F : Z \rightarrow W$. \square

PROPOSITION 5.2.25 (Framed stratified homeomorphisms preserve coarsest refining meshes). *Let (Z, f) and (W, g) be n -tame stratifications with coarsest refining meshes M and N , respectively. Any framed stratified homeomorphism $F : f \cong g$ induces an n -mesh isomorphism $F : M \rightarrow N$ between the coarsest refining meshes.*

PROOF. Since F is a framed stratified homeomorphism from the stratification f to the stratification g , the pushforward mesh F_*M refines g . Thus the mesh F_*M refines the coarsest refining mesh N . If F_*M were strictly finer than N (i.e. the identity is a nontrivial coarsening $F_*M \rightarrow N$), then pulling back along F would yield a nontrivial coarsening $M = F^*(F_*M) \rightarrow F^*N$. But M is already the coarsest refining mesh. Thus $F_*M = N$ and so F is a mesh isomorphism $M \cong N$, as required. \square

5.2.2.2. \star Minimal coarsest refining meshes of tame embeddings.

The notion of coarsest refining meshes of tame stratifications has an analog for tame embeddings. However, defining that analog requires a bit more care, as tame embeddings do not come with a predetermined choice of mesh support.

Once we fix a tame open neighborhood of a tame embedding, there is certainly a canonical coarse mesh, as follows.

REMARK 5.2.26 (Canonical meshes of tame embeddings with neighborhoods). Given an n -tame embedding $\iota : (W, g) \hookrightarrow \mathbb{R}^n$, with a chosen tame

open neighborhood Z , there is a canonical refining open n -mesh with support Z . Specifically, let (Z, g_+) denote the stratification consisting of the strata of $\iota(W, g)$ and the connected components of the complement $Z \setminus \iota(W)$. Note that (Z, g_+) is tame; the desired refining mesh is the coarsest refining mesh of the stratification (Z, g_+) . \square

The preceding construction depends on a choice of tame neighborhood. We can avoid that dependency by considering meshes that both cannot be coarsened and also are minimal, in the following sense.

TERMINOLOGY 5.2.27 (Refining embeddings by meshes). Given an n -tame embedding $\iota : (W, g) \hookrightarrow \mathbb{R}^n$, we say an open n -mesh M ‘refines the embedding’ ι if each stratum in $\iota(W, g)$ is a union of strata of (M_n, f_n) . We will write and draw this refinement as $M \rightarrow \iota$ or $M \rightarrow \iota(W, g)$, as an analog of the coarsening of stratifications. \square

DEFINITION 5.2.28 (Minimal coarsest refining meshes). For a tame embedding ι , a **minimal coarsest refining mesh** is an open mesh M refining the embedding ι , such that

- (1) the mesh M cannot be strictly coarsened to another mesh refining the embedding, and
- (2) the mesh M contains no proper constructible substratification, which is itself an open mesh refining the embedding. \square

EXAMPLE 5.2.29 (Minimal coarsest refining mesh). In [Figure 5.15](#), we depict a tame embedding and a number of meshes refining stratified neighborhoods of that embedding. The embedding is of an X crossing, with closed upper endpoints and open lower endpoints, into \mathbb{R}^2 , with a single stratum. Mesh (a) refines a stratified neighborhood of the embedding, but is not an open mesh and therefore not a refinement of the embedding per se. Mesh (b) can be coarsened to another refining mesh, though it contains no proper constructible substratification that is an open mesh refining the embedding. Mesh (c) cannot be coarsened to another refining mesh, but it does contain a proper constructible substratification that is an open mesh refining the embedding. Mesh (d) is finally a minimal coarsest refining mesh. \square

Further examples of minimal coarsest refining meshes are given later, on the left of [Figure 5.17](#), in [Figure 5.19](#), and in [Figure 5.21](#).

Notice that coarsest refining meshes and minimal coarsest refining meshes are defined rather differently: the former via the universal property of being the coarsest, the latter via the property of being both uncoarsenable and unshrinkable. As a result, the proof of the existence of these structures, though based on similar ideas, has a superficially different structure.

THEOREM 5.2.30 (Canonical meshes of tame embeddings). *Every n -tame embedding has a unique (up to n -mesh isomorphism) minimal coarsest refining n -mesh.*

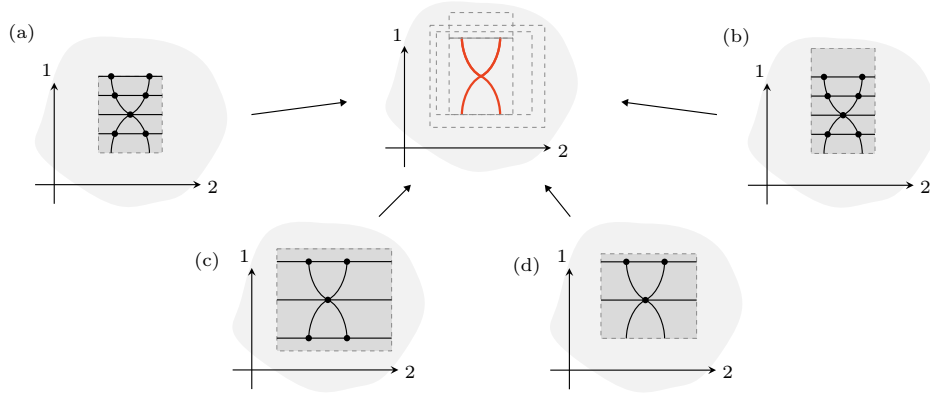

FIGURE 5.15. Refining meshes and a minimal coarsest refining mesh.

PROOF RECIPE. Existence is straightforward: given any refining mesh, repeatedly either strictly coarsen it to another refining mesh or take a proper constructible substratification that is an open refining mesh; as the stratifications are finite, this process must terminate in a minimal coarsest refining mesh. It remains to show the minimal coarsest refining mesh is unique.

First, given the tame embedding $\iota : (W, g) \hookrightarrow \mathbb{R}^n$, construct a ‘projected’ $(n-1)$ -tame embedding $\iota_{n-1} : (W_{n-1}, g_{n-1}) \hookrightarrow \mathbb{R}^{n-1}$, with $W_{n-1} := \pi_n \circ \iota(W) \subset \mathbb{R}^{n-1}$, as follows. Pick any tame open neighborhood Z of $\iota(W)$, and consider the canonical refining mesh M . (In fact, any other refining mesh would also suffice.) Define a filtration

$$X_0 \subset X_1 \subset \cdots \subset X_{n-2} \subset X_{n-1} = W_{n-1},$$

with $X_i^\circ := X_i \setminus X_{i-1}$ being an open subset of the i -skeleton of (M_{n-1}, f_{n-1}) (seen as a cell complex): inductively in decreasing i , set X_i° to be the maximal open subset of X_i on which $\pi_n : \iota(W, g) \rightarrow W_{n-1}$ restricts to a stratified bundle, when stratifying X_i° by its connected components. Then let g_{n-1} be the stratification of W_{n-1} induced by this filtration (as in Remark B.1.49). (The resulting stratification g_{n-1} depends neither on the choice of tame open neighborhood, nor the choice of refining mesh.)

Now pick two minimal coarsest refining meshes M and M' of the tame embedding ι . Observe that the $(n-1)$ -truncations (M_{n-1}, f_{n-1}) and (M'_{n-1}, f'_{n-1}) are minimal coarsest refining meshes of ι_{n-1} . By induction, there is an $(n-1)$ -mesh isomorphism $F_{n-1} : (M_{n-1}, f_{n-1}) \cong (M'_{n-1}, f'_{n-1})$, thus in particular an isomorphism of the corresponding fundamental trusses. Further inductively claim and assume that identified strata coincide pointwise, except when one stratum has points outside the support of the mesh containing the other stratum. For the inductive step: note that neither (M_n, f_n) nor (M'_n, f'_n) can have singular strata with points outside the support of the other mesh (since removing all such singular strata would yield a coarser refining mesh); and singular strata in the joint support $M_n \cap M'_n$ must be identical

in the two meshes (otherwise construct a coarser refining mesh by taking a mesh bundle join). That much implies the inductive claim about strata coinciding, and shows that M and M' have identical fundamental trusses, therefore are isomorphic as meshes, as required. \square

Note that, in fact, the framed stratified homeomorphism constructed in the preceding proof, between two minimal coarsest refining meshes, can (inductively) be chosen to completely fix all strata that pointwise coincide in the two meshes.

OBSERVATION 5.2.31 (Minimal coarsest mesh inductive construction). There is a more systematic construction of a minimal coarsest mesh, of a tame embedding $\iota : (W, g) \hookrightarrow \mathbb{R}^n$, as follows. First, by induction, construct a minimal coarsest refining $(n - 1)$ -mesh (M_{n-1}, f_{n-1}) of the projected tame embedding ι_{n-1} (obtained as in the preceding proof recipe). Next, refine g (only as much as necessary) to obtain a stratified bundle $\tilde{g} \rightarrow f_{n-1}$. Finally, construct a minimal coarsest refining 1-mesh bundle $\tilde{\tilde{g}} \rightarrow f_{n-1}$, that refines the stratified bundle \tilde{g} ; this extends the $(n - 1)$ -mesh to an n -mesh and provides the required minimal coarsest refining n -mesh of ι . \square

LEMMA 5.2.32 (Framed stratified homeomorphisms preserve minimal coarsest refining meshes). *Let $\iota : (W, g) \hookrightarrow \mathbb{R}^n$ and $\iota' : (W', g') \hookrightarrow \mathbb{R}^n$ be n -tame embeddings with minimal coarsest refining meshes M and N , respectively. If there is a framed stratified homeomorphism $\iota \cong \iota'$, then there exists an n -mesh isomorphism $M \cong N$ between the minimal coarsest refining meshes.*

PROOF. Observe that given a tame embedding, for any tame open neighborhood Z , there is a minimal coarsest refining mesh contained in Z . (By an inductive argument, any minimal coarsest refining mesh can have its support shrunk sufficiently, while fixing all strata entirely contained in Z .) By definition, the framed stratified homeomorphism of tame embeddings is a homeomorphism of tame open neighborhoods (that restricts to a stratified homeomorphism of the embedding images); a minimal coarsest refining mesh may be transported across that homeomorphism. The result follows from the uniqueness assurance of [Theorem 5.2.30](#). \square

5.2.3. Examples of coarsest meshes. We illustrate a range of examples of coarsest refining meshes of tame stratifications and minimal coarsest refining meshes of tame embeddings, in dimensions 2, 3, and 4. We see in practice how these coarsest meshes record changes in the stratified homeomorphism type of the fibers of the standard tower of projections, wholistically encoding all the singularities of all strata under those projections along with the interactions local and nonlocal of those singularities and strata.

EXAMPLE 5.2.33 (Coarsest and non-coarsest refining meshes). In [Figure 5.16](#), we depict a tame stratification, in the middle, along with two refinements on the left and right. The right refinement coarsens to the left

refinement and is therefore not itself coarsest; the left refinement is in fact the coarsest refining mesh.

In Figure 5.17, we similarly depict a tame embedding, in the middle, along with two refinements on the left and right. Again the right refinement coarsens to the left, and is therefore not minimal coarsest; the left refinement is the minimal coarsest refining mesh. —

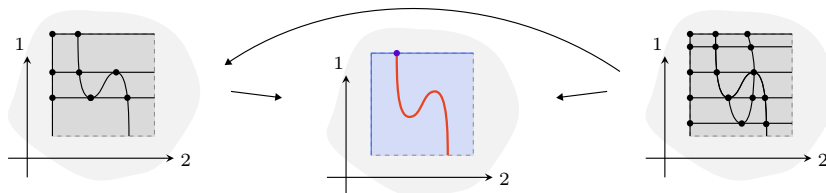

FIGURE 5.16. Refining meshes of a tame stratification.

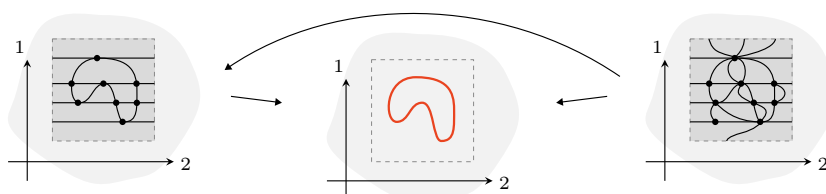

FIGURE 5.17. Refining meshes of a tame embedding.

EXAMPLE 5.2.34 (Coarsest and minimal coarsest meshes in dimension 2). In Figure 5.18, we depict two 2-tame stratifications, namely a stratified polytope (on the left) and an unstratified polytope (on the right), along with their shared coarsest refining mesh.

In Figure 5.19, we depict two 2-tame embeddings, namely the figure eight with a basepoint stratum (on the left) and the figure eight as a single stratum (on the right), along with their shared minimal coarsest refining mesh. —

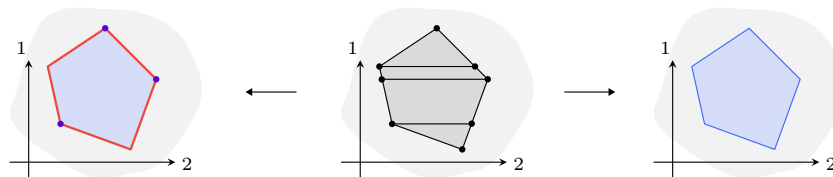

FIGURE 5.18. The coarsest refining mesh of two 2-tame stratifications.

EXAMPLE 5.2.35 (Coarsest meshes in dimension 3). In Figure 5.20, we depict the coarsest refining meshes of two 3-tame stratifications. The lower left stratification is a cylinder with a single 3-dimensional bulk stratum and

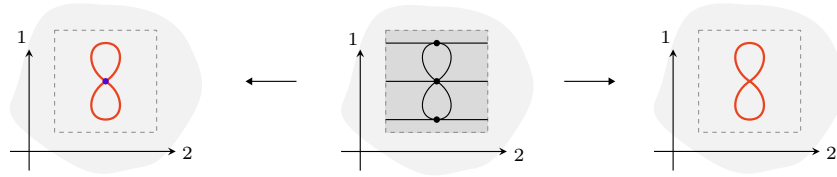

FIGURE 5.19. The minimal coarsest refining mesh of two 2-tame embeddings.

a single 1-dimensional line stratum. Notice that the line stratum has no singularities with respect to either the projection to \mathbb{R}^2 or to \mathbb{R}^1 . Nevertheless in the coarsest refining mesh it is split into three segments, because the left and right edges of the cylinder are singular for the projection to \mathbb{R}^2 , and the line stratum intersects those singular loci at two points.

The lower right stratification is a half-closed half-open prism with two 3-dimensional bulk strata and a single 2-dimensional surface stratum. The surface stratum has a smooth arc of singularities of the projection to \mathbb{R}^2 , and that arc itself has a cuspidal point singularity for that projection and also at the same point an ordinary Morse singularity for the projection to \mathbb{R}^1 . The coarsest mesh isolates the singular arc and splits it at the cusp point. \square

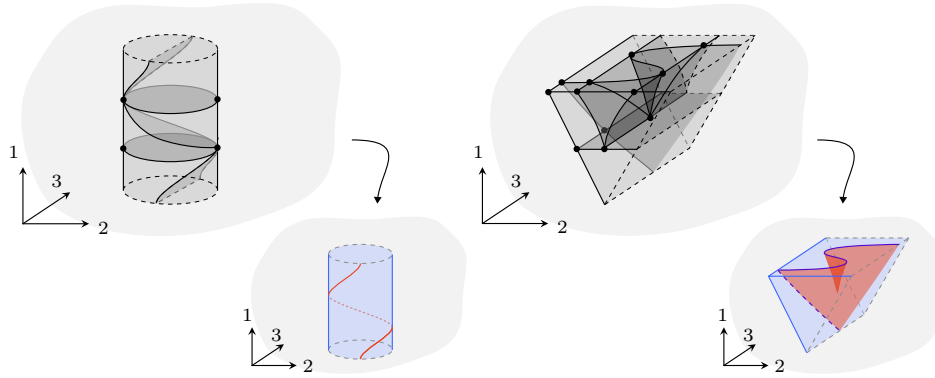

FIGURE 5.20. Coarsest meshes of 3-tame stratifications.

EXAMPLE 5.2.36 (Minimal coarsest meshes in dimension 3). In Figure 5.21, we depict the minimal coarsest refining meshes of two 3-tame embeddings (both trivially stratified). The lower left embedding is a pair of pants surface. Its minimal coarsest mesh records the seams of those pants (singular for projection to \mathbb{R}^2) and the split of the inner seam at its central point (singular for projection from the seam to \mathbb{R}^1).

On the lower right is the Hopf embedding of the circle, that is, an embedding ι such that the projection $\pi_3 \circ \iota : S^1 \rightarrow \mathbb{R}^2$ is an immersion with a single double point. The minimal coarsest mesh records the preimages of that double point, along with the two Morse points of the projection to \mathbb{R}^1 . This

open mesh is dual to a closed mesh, which in turn corresponds to a regular cell complex; in this sense, that regular cell complex is dual to the Hopf circle, as illustrated and informally observed all the way back in Figure 1.55. \square

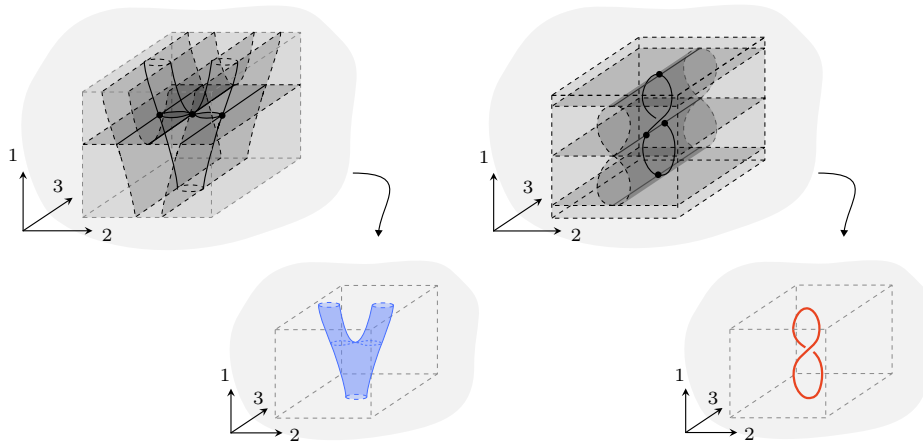

FIGURE 5.21. Minimal coarsest meshes of 3-tame embeddings.

EXAMPLE 5.2.37 (Coarsest meshes in dimension 4). Recall from Example 5.1.10 the description of the two 4-tame stratifications illustrated in Figure I.7, encoding respectively the third Reidemeister move and the swallowtail singularity. In Figure I.8 and Figure I.9, we depicted the coarsest refining meshes of these two stratifications. In the Reidemeister case, the second stage of the mesh provides a concise portrait of the geometry of the braid crossings. Similarly in the swallowtail case, the second stage of the mesh displays the interaction of the two cusp points with the self braiding of the fold locus. \square

5.3. Tractability of tame stratifications

By assumption, a tame stratification admits a refining mesh, and by hard work, it admits a coarsest refining mesh. That mesh, together with the amalgamation of its strata according to the tame stratification, is called a *stratified mesh*. The fundamental truss of that mesh, together with the corresponding amalgamation of its elements into posetal strata, is called a *stratified truss*. Furthermore, because the refining mesh could not be further coarsened, the resulting truss is *normalized* in the sense that it also cannot be coarsened while respecting the decomposition structure of the tame stratification. Altogether then, as long anticipated, tame stratifications are classified by normalized stratified trusses, and tame embeddings are similarly classified by normalized stratified trusses that are ‘ambient’ in allowing some surrounding unstratified regions. An example of a tame embedding and its classifying normalized ambient stratified truss is illustrated in Figure 5.22. The embedding, on the left, is of a single-stratum open triangular surface, arranged so that the top projection has a cuspidal singularity. The stratified truss, on the right, encodes this cusp behavior combinatorially, with nine singular elements of the top 2-truss slice converging, in the upper 2-truss bordism, to the central singular element of the 3-truss.

In that depiction of the cusp embedding and its classifying truss, the embedding has a smooth character while the truss appears rather *polyhedral* (in being a piecewise linear assemblage of linearly embedded simplices); the claimed correspondence suggests that the smooth version is in some sense equivalent to the piecewise linear version. That sense is the eventual fact that every tame embedding is framed stratified homeomorphic to an embedding with polyhedral image, and conversely every polyhedral stratification is the image of a tame embedding. The classification of tame embeddings provides not only this piecewise linearization of tame objects, but more deeply controls tame maps between them. The headline instance of that control is the *framed Hauptvermutung*: every framed stratified homomorphism of polyhedral stratifications is homotopic to a framed stratified piecewise linear homeomorphism.

Whenever a geometric structure has a finitary combinatorial classification, one may hope that classification provides an algorithmic handle on relevant geometric questions; and whenever one has that hope, one must cautiously remember that many seemingly finite combinatorial problems are not algorithmically decidable. Nevertheless, of course, the intrinsic constructibility of trusses, and their stratified variations, provides the necessary leverage. From a stratified truss, one may deterministically compute its normalization, i.e. maximal coarsening; thus from a stratified mesh, one may compute its coarsest coarsening; and thus finally, equivalence (that is, framed stratified homeomorphism) of tame stratifications is *computable*. That computable decidability extends beyond structures embedded in euclidean space. Recall that n -directed acyclic graphs are framed complexes that may not embed

in euclidean space but merely map to it, in a way that locally controls the directed structure. In an oblique and closing counterpart to the embedded case, equivalence (that is, framed homeomorphism) of n -directed acyclic graphs will also prove to be decidable.

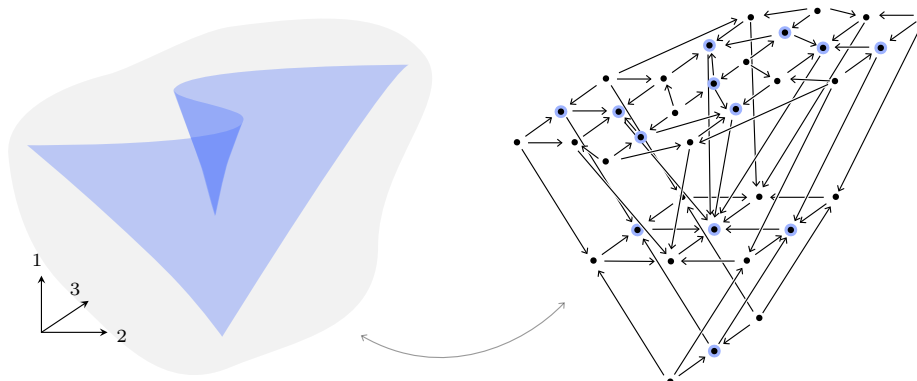

FIGURE 5.22. The cusp embedding and its normalized ambient stratified truss.

OUTLINE. In Section 5.3.1, after recalling and introducing stratified trusses and stratified meshes, respectively, we observe that normalized trusses and coarsest meshes correspond via the fundamental stratified truss and stratified mesh realization, and prove the headline classifications of tame stratifications and of tame embeddings. In Section 5.3.2, we introduce polyhedral stratifications, and show both that tame embeddings are polyhedral and polyhedral stratifications are tame; we then discuss the failure of classical versions of the Hauptvermutung concerning homeomorphisms of polyhedra, and prove the framed Hauptvermutung, that framed stratified homeomorphisms of polyhedral stratifications are homotopic to framed stratified piecewise linear homeomorphisms. Finally, in Section 5.3.3, we prove that framed stratified homeomorphism of tame stratifications is decidable, and in a similar vein that framed homeomorphism of n -directed acyclic graphs is decidable.

5.3.1. Combinatorializability.

SYNOPSIS. We recall the notion of stratified trusses, as labeled trusses whose labeling is the characteristic map of a stratification, and the notion of normalized stratified trusses as those admitting no label-preserving truss coarsening. We then define stratified meshes, as tame stratifications equipped with a choice of mesh refinement. We provide a correspondence between stratified trusses and stratified meshes, via a fundamental stratified truss construction and a stratified mesh realization construction. We observe that a stratified mesh has no mesh coarsening exactly when the corresponding stratified truss is normalized, and thereby complete the proof of the classification of tame stratifications by normalized stratified trusses. Finally, we

discuss bundles of tame stratifications and their classification by normalized stratified truss bundles.

5.3.1.1. Stratified trusses. Recall from Definition 5.1.21 that a stratified n -truss is a poset-labeled n -truss T whose labeling lbl_T is the characteristic map of a stratification on the total poset T_n .

NOTATION 5.3.1 (Fundamental posets and strata of stratified trusses). To highlight that a labeled truss $T = (T, \text{lbl}_T)$ is a stratified truss, we will usually denote the poset of labels by $\Pi(T)$, and refer to it as the ‘fundamental poset’ of the stratified truss. The ‘strata’ of the stratified truss T are, by definition, the connected subposets of T_n given by the preimages $\text{lbl}_T^{-1}(x)$, for $x \in \Pi(T)$. —

EXAMPLE 5.3.2 (Stratified trusses). In Figure 5.23, we depict a stratified 2-truss with four strata. We indicate the labeling map lbl_T by coloring preimages in the same color as their target object in the labeling poset. In later examples, we often leave the labeling map implicit, and simply provide the coloring of the total poset of the stratified truss. —

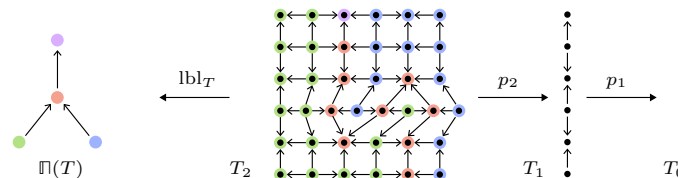

FIGURE 5.23. A stratified 2-truss.

The condition on a stratified truss, that the labeling map is a characteristic map, can be rephrased combinatorially as follows.

TERMINOLOGY 5.3.3 (Quotient and connected-quotient maps). A ‘quotient map’ of posets is a surjective poset map for which a subposet of the codomain is open if and only if its preimage is open in the domain. (Recall a subposet is open when it is downward closed.) A ‘connected-quotient map’ of posets is a quotient map of posets whose preimages are connected. —

OBSERVATION 5.3.4 (Characteristic maps are connected-quotient maps). A labeling $\text{lbl}_T : T_n \rightarrow P$ of a truss T in a poset P is the characteristic map of a stratification if and only if it is a connected-quotient map. This is shown (in a slightly more general form) in Lemma B.1.40. —

REMARK 5.3.5 (Stratification from subset decomposition). Given an n -truss T , any decomposition of T_n into connected subposets determines a stratified n -truss, with underlying truss T and with strata being the given subposets. —

As a consequence of the preceding remark, we can construct stratified trusses from arbitrary poset-labelings, as follows.

CONSTRUCTION 5.3.6 (Stratifications from poset labelings). Given any poset-labeled truss $T = (\underline{T}, \text{lbl}_T)$, there is an associated stratified truss \tilde{T} , with strata being the connected components of the nonempty preimages of the labeling lbl_T . (This is an example of the ‘connected component splitting’ construction, formalized in Construction B.1.45 in the broader context of general stratifications.) —

EXAMPLE 5.3.7 (Truss stratifications via poset-labelings). The preceding construction is convenient when illustrating stratified trusses: we may replace a given characteristic map with a labeling in a smaller poset, whose connected component splitting recovers the characteristic map; this reduces the number of labeling colors, without any sacrifice in clarity. For instance, Figure 5.24 depicts a poset labeling of a truss, whose associated stratification is the one previously given in Figure 5.23. —

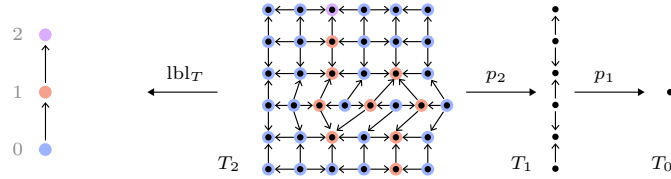

FIGURE 5.24. A stratified truss represented by a poset labeling.

TERMINOLOGY 5.3.8 (Ambient stratified trusses). An ‘ambient stratified n -truss’ is a stratified truss T with a chosen subset of strata $A \subset \mathbb{N}(T)$ called ‘ambient strata’. In illustrations of ambient stratified trusses, we typically leave the ambient strata uncolored and indicate the corresponding poset element by a white circle. —

Note that in practice, we will be concerned exclusively with the case when each ambient stratum is open (and the terminology is meant to suggest this), but we do not insist on this condition.

EXAMPLE 5.3.9 (An ambient stratified truss). In Figure 5.25, we depict an ambient stratified 2-truss, utilizing both our convention for uncolored ambient strata and for poset-labeled stratifications. There is a single ‘0-dimensional’ stratum, colored pastel purple, two ‘1-dimensional’ strata, colored pastel red, and three ‘2-dimensional’ strata, uncolored. —

The notion of maps of stratified trusses is directly inherited from the notion of maps of labeled trusses, see Terminology 2.3.34, as follows.

DEFINITION 5.3.10 (Maps of stratified trusses). A **map of stratified n -trusses** $F : T \rightarrow S$ is simply a map of labeled n -trusses; i.e. there is an underlying map of n -trusses $\underline{F} : \underline{T} \rightarrow \underline{S}$ and a map of labelings $\text{lbl}_F : \mathbb{N}(T) \rightarrow \mathbb{N}(S)$ such that $\text{lbl}_F \circ \text{lbl}_T = \text{lbl}_S \circ F_n$. —

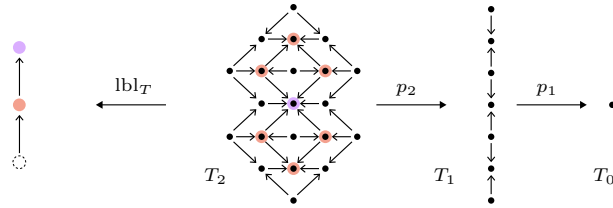

FIGURE 5.25. An ambient stratified 2-truss.

Note that a map of stratified trusses provides an actual map of stratifications of the total posets (see Definition B.2.1).

Recall that a map of labeled n -trusses was called a coarsening (see Terminology 2.3.65) when every constituent 1-truss bundle map is a surjective regular map preserving endpoint types. In the specific case of stratified trusses, we restrict the use of that term, and also distinguish two special cases, as follows.

TERMINOLOGY 5.3.11 (Coarsenings of stratified trusses). Let $F : T \rightarrow S$ be a map of stratified n -trusses.

- › The map F is a ‘label coarsening’ if the underlying truss map \underline{F} is the identity, and the label map lbl_F is a connected-quotient map (see Terminology 5.3.3).
- › The map F is a ‘truss coarsening’ if the underlying truss map \underline{F} is a coarsening of n -trusses, and the label map lbl_F is the identity.
- › The map F is a ‘coarsening’ if the underlying truss map \underline{F} is a coarsening of n -trusses, and the label map lbl_F is a connected-quotient map. —

With this terminology at hand, recall from Definition 5.1.22 that a stratified truss is normalized when it has no non-identity (label-preserving) truss coarsening.

REMARK 5.3.12 (Label coarsenings are stratified coarsenings). Note that, when the stratified truss map $(\underline{F}, \text{lbl}_F) : (\underline{T}, \text{lbl}_T) \rightarrow (\underline{S}, \text{lbl}_S)$ is a label coarsening, the top component $\underline{F}_n = \text{id}_{T_n}$ of the identity truss map $\underline{F} = \text{id}_T$ induces a coarsening of stratified spaces $(T_n, \text{lbl}_T) \rightarrow (T_n, \text{lbl}_S)$ (see Lemma B.2.12). —

EXAMPLE 5.3.13 (A truss coarsening). In Figure 5.26, we depict a truss coarsening F of stratified 2-trusses. By Terminology 5.3.11, the label map is the identity, and is not drawn. Note that the target of this coarsening is still not normalized. —

Note that every coarsening can be written both as a unique composite of a truss coarsening followed by a label coarsening, and as a unique composite of a label coarsening followed by a truss coarsening.

Recall that truss blocks and truss braces (see Definition 2.3.73 and Definition 2.3.100) are the local building components of closed trusses and of

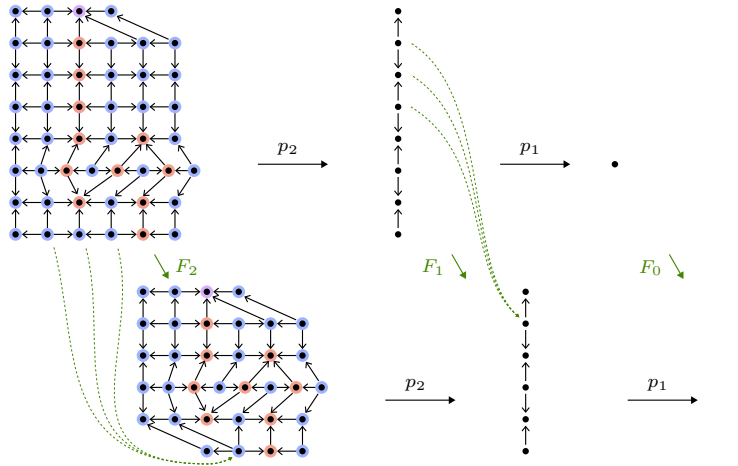

FIGURE 5.26. A truss coarsening of stratified trusses.

open trusses, respectively. Anticipating our development of tame cells and tame singularities as local components of tame stratifications, we introduce the following combinatorial components of stratified trusses.

DEFINITION 5.3.14 (Truss cells and truss singularities). An n -**truss** m -**cell** T is a stratified n -truss m -block whose initial element $\perp \in T_n$ is label isolated, in the sense that $\text{lbl}_T^{-1}(\text{lbl}_T(\perp)) = \{\perp\}$.

Dually, an n -**truss** m -**singularity** T is a stratified n -truss m -brace whose terminal element $\top \in T_n$ is label isolated. ┌

EXAMPLE 5.3.15 (Truss singularities). In Figure 5.27, we depict a few truss singularities: in the first row, the first two are 2-truss 0-singularities and the third is a 2-truss 1-singularity; in the second row, the first is a 3-truss 1-singularity and the second is a 3-truss 2-singularity. For each n -truss m -singularity, the terminal element will later correspond to a stratum of a tame singularity of dimension m .

Dual truss cells, of each truss singularity, can be obtained by stagewise dualizing the given posets. For each resulting n -truss $(n - m)$ -cell, the initial element will later correspond to a stratum of a tame cell of dimension $n - m$. └

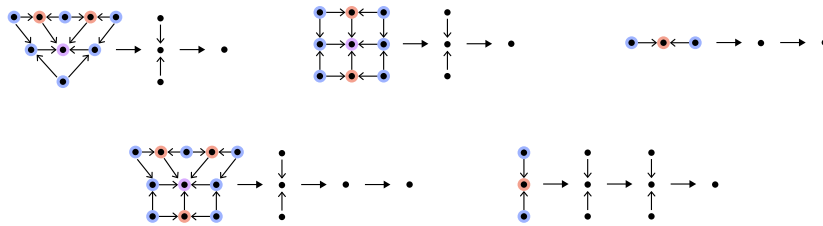

FIGURE 5.27. Truss singularities.

5.3.1.2. Stratified meshes. As a stratified truss is a truss together with groupings of its elements into strata, a *stratified mesh* is a mesh together with groupings of its cells into strata; in fact we have already encountered that structure (viewed from the opposite perspective) as a tame stratification together with a mesh refinement.

DEFINITION 5.3.16 (Stratified meshes). A **stratified n -mesh** is an n -tame stratification (Z, f) together with a choice of refining mesh $M \rightarrow f$. \square

Recall that the notation $M \rightarrow f$, for a refining mesh of a tame stratification, is shorthand for a refinement $(M_n, f_n) \rightarrow (Z, f)$ by the top stage of the mesh. We will typically denote a stratified mesh by the pair (M, f) , leaving the refinement implicit; this notation also suggests the interpretation that the stratification f is a stratification ‘of the mesh M ’ in the sense that it encodes a merging of the mesh cells into larger strata.

DEFINITION 5.3.17 (Maps of stratified meshes). A **map of stratified n -meshes** $F : (M, f) \rightarrow (N, g)$ is an n -mesh map $F : M \rightarrow N$ whose top component $F_n : (M_n, f_n) \rightarrow (N_n, g_n)$ induces a map of stratifications $f \rightarrow g$. \square

Recall that a map of n -meshes was called a coarsening (see Terminology 4.1.91) when every constituent 1-mesh bundle map is a coarsening on every fiber. In the specific case of stratified meshes, we restrict the use of that term, and distinguish two special cases.

TERMINOLOGY 5.3.18 (Coarsenings of stratified meshes). Let $F : (M, f) \rightarrow (N, g)$ be a map of stratified n -meshes.

- > The map F is a ‘stratification coarsening’ if $M = N$, and $F_n : f \rightarrow g$ is a coarsening of stratifications.
- > The map F is a ‘mesh coarsening’ if $F : M \rightarrow N$ is a coarsening of n -meshes, and $f = g$.
- > The map F is a ‘coarsening’ if $F : M \rightarrow N$ is a coarsening of n -meshes and $F_n : f \rightarrow g$ is a coarsening of stratifications. \square

EXAMPLE 5.3.19 (A mesh coarsening). In Figure 5.28, we depict a mesh coarsening of stratified 2-meshes. \square

Recall from Definition 5.3.14 that a truss cell is a stratified truss block whose initial element is label isolated, and similarly a truss singularity is a stratified truss brace whose terminal element is label isolated. The precisely corresponding notions for stratified meshes are as follows.

DEFINITION 5.3.20 (Mesh cells and singularities). An **n -mesh m -cell** (M, f) is a stratified n -mesh m -block, for which the refinement $M \rightarrow f$ maps the (dense) m -dimensional stratum of M_n onto a stratum of f .

Dually, an **n -mesh m -singularity** (M, f) is a stratified n -mesh m -brace, for which the refinement $M \rightarrow f$ maps the m -dimensional cone stratum of M_n onto a stratum of f . \square

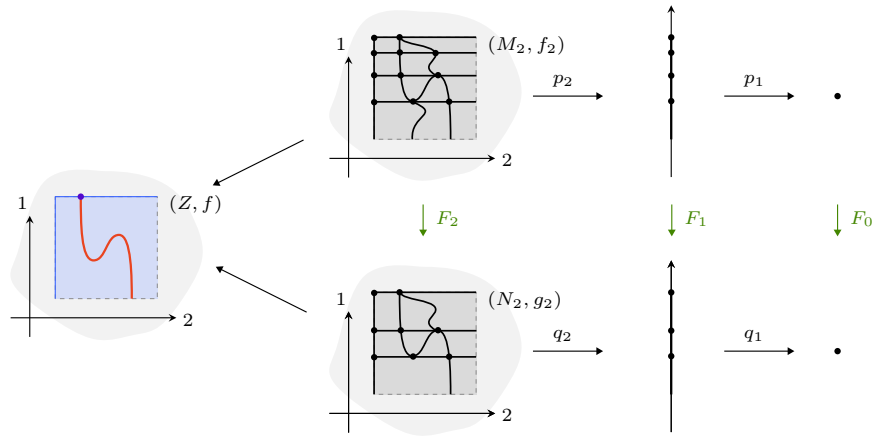

FIGURE 5.28. A mesh coarsening of stratified meshes.

EXAMPLE 5.3.21 (Mesh cells and singularities). In Figure 5.29, we depict three stratified 2-mesh singularities (M, f) . In each case, the refining mesh is shown on top, and the tame stratification is shown on the bottom. The first two are 2-mesh 0-singularities, while the third is a 2-mesh 1-singularity. For each truss m -singularity, the cone stratum is of dimension m .

In Figure 5.30 we depict the dual stratified 2-mesh cells. The first two are 2-mesh 2-cells, and the third is a 2-mesh 1-cell. Naturally, the dense cell of each mesh m -cell is of dimension m . □

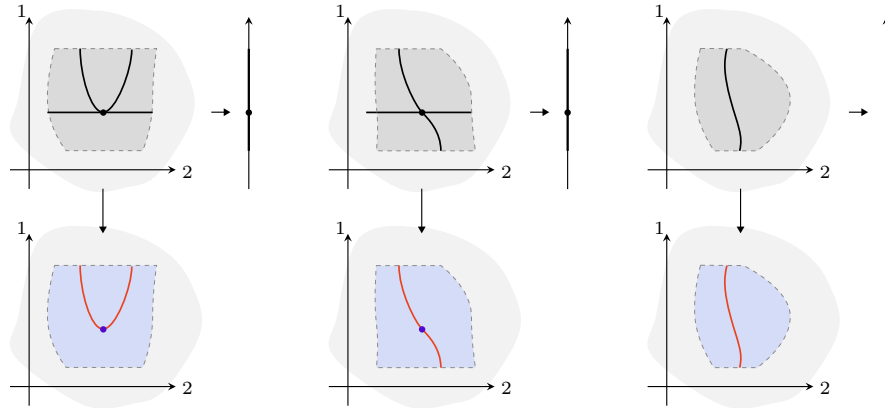

FIGURE 5.29. Mesh singularities.

5.3.1.3. Correspondence of stratified trusses and stratified meshes. Based of course on the equivalence between bare trusses and meshes, we now describe the correspondence between stratified trusses and stratified meshes.

In one direction, to pass from stratified meshes to stratified trusses, we may take the fundamental stratified truss, as follows.

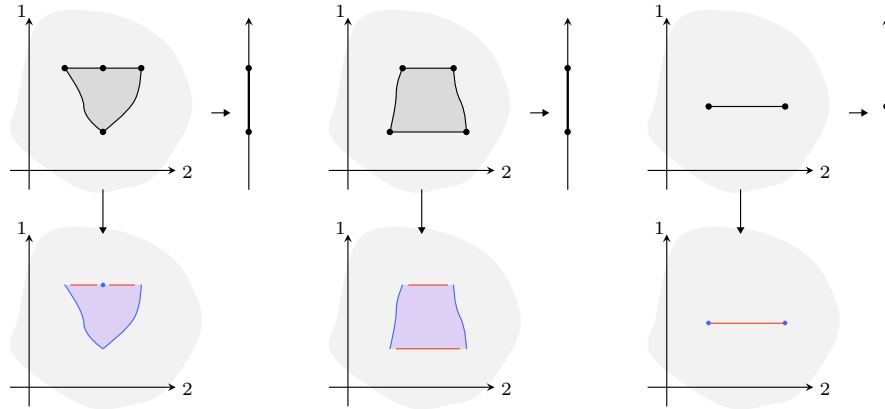

FIGURE 5.30. Mesh cells.

DEFINITION 5.3.22 (Fundamental stratified trusses). Given a stratified n -mesh (M, f) , the **fundamental stratified truss** $\mathbb{P}_T(M, f)$ is the stratified n -truss $(\mathbb{P}_T M, \mathbb{P}_{|\text{bl}|}(M, f))$, whose underlying truss is the fundamental truss $\mathbb{P}_T M$ of the mesh M , and whose labeling $\mathbb{P}_{|\text{bl}|}(M, f)$ is the fundamental poset map $\mathbb{P}(f_n \rightarrow f)$ of the coarsening of stratifications $f_n \rightarrow f$. \square

EXAMPLE 5.3.23 (A stratified mesh and its fundamental stratified truss). Recall the stratified mesh in the top row of Figure 5.28. The fundamental stratified truss of that stratified mesh is the stratified truss in the top row of Figure 5.26. \square

DEFINITION 5.3.24 (Fundamental stratified truss maps). Given a map of stratified meshes $F : (M, f) \rightarrow (N, g)$, the **fundamental stratified truss map** $\mathbb{P}_T F : \mathbb{P}_T(M, f) \rightarrow \mathbb{P}_T(N, g)$ is the map of stratified trusses whose underlying map of trusses is the fundamental truss map $\mathbb{P}_T(F : M \rightarrow N)$, and whose labeling map is the fundamental poset map $\mathbb{P}(F_n : f \rightarrow g)$. \square

EXAMPLE 5.3.25 (A mesh coarsening and its fundamental stratified truss coarsening). The fundamental stratified truss map of the mesh coarsening in Figure 5.28 is the truss coarsening in Figure 5.26. \square

In the other direction, to pass from stratified trusses to stratified meshes, we may take the stratified mesh realization, as follows. We will make use of the fact that stratified coarsenings of a given stratification are determined by connected-quotient maps of the fundamental poset of the stratification (see Lemma B.2.12).

DEFINITION 5.3.26 (Stratified mesh realizations). Given a stratified n -truss $T = (\underline{T}, \text{bl}_T)$, the **stratified mesh realization** $\|\underline{T}\|_M$ is the stratified n -mesh $(\|\underline{T}\|_M, \|T\|_{\text{str}})$, whose underlying mesh is the mesh realization $\|\underline{T}\|_M$ of the truss \underline{T} , and whose stratification $\|T\|_{\text{str}}$ is determined by coarsening the stratification $(\|\underline{T}\|_M)_n$ according to the fundamental poset map $\mathbb{P}(\text{bl}_T)$ of the labeling of the stratified truss. \square

DEFINITION 5.3.27 (Stratified mesh map realizations). Given a map $F = (\underline{F}, \text{lbl}_F) : T \rightarrow S$ of stratified trusses $T = (\underline{T}, \text{lbl}_T)$ and $S = (\underline{S}, \text{lbl}_S)$, the **stratified mesh map realization** $\|F\|_{\mathbb{M}} : \|T\|_{\mathbb{M}} \rightarrow \|S\|_{\mathbb{M}}$ is the map of stratified meshes given by the mesh map realization $\|\underline{F}\|_{\mathbb{M}} : \|\underline{T}\|_{\mathbb{M}} \rightarrow \|\underline{S}\|_{\mathbb{M}}$. —

Note that the top component of the stratified mesh map realization indeed induces a stratified map $(\|F\|_{\mathbb{M}})_n : \|T\|_{\text{str}} \rightarrow \|S\|_{\text{str}}$, as required.

The equivalence of meshes and trusses (see Section 4.2) implies that the fundamental stratified truss and stratified mesh realization provide an equivalence in the stratified case, in the following sense.

PROPOSITION 5.3.28 (Correspondence of stratified meshes and trusses). *Let T be a stratified truss, and let (M, f) be a stratified mesh.*

- (1) *There is a unique isomorphism of stratified trusses $T \cong \mathbb{T}(\|T\|_{\mathbb{M}})$.*
- (2) *There is an isomorphism of stratified meshes $(M, f) \cong \|\mathbb{T}(M, f)\|_{\mathbb{M}}$, which is unique up to contractible choice of homotopy.*

PROOF. The first claim follows since there is a unique isomorphism of trusses $\underline{T} \cong \mathbb{T}\|\underline{T}\|_{\mathbb{M}}$, and since (suppressing that isomorphism) an equality of labelings $\mathbb{T}_{\text{lbl}}(\|T\|_{\text{str}}) = \text{lbl}_T$. The second claim follows since there is a mesh isomorphism $M \cong \|\mathbb{T}M\|_{\mathbb{M}}$, unique up to contractible choice of homotopy by the balanced case of weak faithfulness of the fundamental truss (see Proposition 4.2.40 and Remark 4.2.41), and that isomorphism induces a stratified homeomorphism $f \cong \|\mathbb{T}(M, f)\|_{\text{str}}$. \square

REMARK 5.3.29 (Correspondence of stratified mesh and truss maps). The fundamental stratified truss and stratified mesh realization also provide a mutual inverse correspondence in the case of maps of stratified meshes and stratified trusses (up to contractible choice of homotopy on the stratified mesh map side). —

Recall that the mesh realization of a truss coarsening need not be a coarsening, and that necessitated Construction 4.2.78 of a special mesh coarsening realization for truss coarsenings. The realization of stratified truss coarsenings requires corresponding care, as follows.

DEFINITION 5.3.30 (Stratified mesh coarsening realization). Given a coarsening of stratified trusses $F : T \rightarrow S$, the **stratified mesh coarsening realization** $\|F\|_{\mathbb{M}}^{\text{crs}} : \|T\|_{\mathbb{M}} \rightarrow \|S\|_{\mathbb{M}}$ is the map of stratified meshes given by the mesh coarsening realization $\|\underline{F}\|_{\mathbb{M}}^{\text{crs}} : \|\underline{T}\|_{\mathbb{M}} \rightarrow \|\underline{S}\|_{\mathbb{M}}$. —

Note that the top component of the stratified mesh coarsening realization does induce a stratified map $(\|F\|_{\mathbb{M}}^{\text{crs}})_n : \|T\|_{\text{str}} \rightarrow \|S\|_{\text{str}}$, as required.

OBSERVATION 5.3.31 (Correspondence of coarsening notions). Given a coarsening, or a mesh coarsening, or a stratification coarsening $F : (M, f) \rightarrow (N, g)$ of stratified meshes, then the fundamental stratified truss map $\mathbb{T}(F) : \mathbb{T}(M, f) \rightarrow \mathbb{T}(N, g)$ is, respectively, a coarsening, or a truss coarsening, or a label coarsening of stratified trusses.

Conversely, given a coarsening, or a truss coarsening, or a label coarsening $F : T \rightarrow S$ of stratified trusses, then the stratified mesh coarsening realization $\|F\|_{\mathbb{M}}^{\text{crs}} : \|T\|_{\mathbb{M}} \rightarrow \|S\|_{\mathbb{M}}$ is, respectively, a coarsening, or a mesh coarsening, or a stratification coarsening of stratified meshes. \square

5.3.1.4. Normalization and coarsest refinements. Recall that by Definition 5.2.22, a coarsest refining mesh of a tame stratification is one that is coarser than any other refining mesh, and of course in practice any refining mesh that cannot be coarsened is a coarsest refining mesh. We can rephrase this notion in terms of stratified meshes as follows: a coarsest refining mesh M of a tame stratification f is a stratified mesh (M, f) that admits no non-identity (stratification-preserving) mesh coarsening. That rephrasing has an immediate combinatorial correlate, already presented in Definition 5.1.22: a normalized stratified truss is a stratified truss $(\underline{T}, \text{lbl}_T)$ that admits no non-identity (label-preserving) truss coarsening.

The correspondence of stratified meshes and trusses thus specializes as follows.

LEMMA 5.3.32 (Relating coarsest refinements and normalization). *Consider a stratified mesh (M, f) and a stratified truss T , such that T is the stratified fundamental truss of (M, f) , or equivalently (M, f) is the stratified mesh realization of T . The mesh M is the coarsest refining mesh of the stratification f if and only if the stratified truss T is normalized.*

PROOF. By Observation 5.3.31, any mesh coarsening provides (on the fundamental stratified truss) a truss coarsening, and any truss coarsening provides (on the stratified mesh realization) a mesh coarsening; thus the stratified mesh cannot be mesh coarsened exactly when the stratified truss cannot be truss coarsened. \square

This lemma provides the last ingredient for the proof of the classification of tame stratifications by normalized stratified trusses.

PROOF OF THEOREM 5.1.23. Given a tame stratification (Z, f) , we may take its coarsest refining mesh M (by Theorem 5.2.23). Changing the tame stratification by a framed stratified homeomorphism only changes the coarsest refining mesh by a mesh isomorphism (by Proposition 5.2.25). Next form the fundamental stratified truss $\mathbb{T}(M, f)$; that truss is normalized, by Lemma 5.3.32.

Conversely, given a normalized stratified truss T , we take its stratified mesh realization $\|T\|_{\mathbb{M}} = (\|\underline{T}\|_{\mathbb{M}}, \|T\|_{\text{str}})$, and so have in particular the corresponding tame stratification $\|T\|_{\text{str}}$. Changing the stratified truss by a balanced isomorphism only changes the tame stratification by a framed stratified homeomorphism. Note that the mesh $\|\underline{T}\|_{\mathbb{M}}$ is a coarsest refining mesh of $\|T\|_{\text{str}}$, again by Lemma 5.3.32.

These two associations are mutually inverse, as required, by Proposition 5.3.28. \square

We may now state and prove the analogous classification for tame embeddings.

THEOREM 5.3.33 (Classification of tame embeddings). *Framed stratified homeomorphism classes of n -tame embeddings are in correspondence with isomorphism classes of normalized ambient stratified open n -trusses.*

PROOF. The proof is analogous to that of [Theorem 5.1.23](#), but uses the minimal coarsest refining mesh instead of the coarsest refining mesh; the strata of the mesh that are not in the image of the embedding are considered ambient, and become the ambient strata of the fundamental stratified truss. \square

EXAMPLE 5.3.34 (Classifying 2-tame stratifications and embeddings). In [Figure 5.31](#), we illustrate the classification of tame stratifications and embeddings in dimension 2. The first case depicts a 2-tame stratification and its corresponding normalized stratified truss. The second and third cases depict 2-tame embeddings and their corresponding normalized ambient stratified open trusses. \square

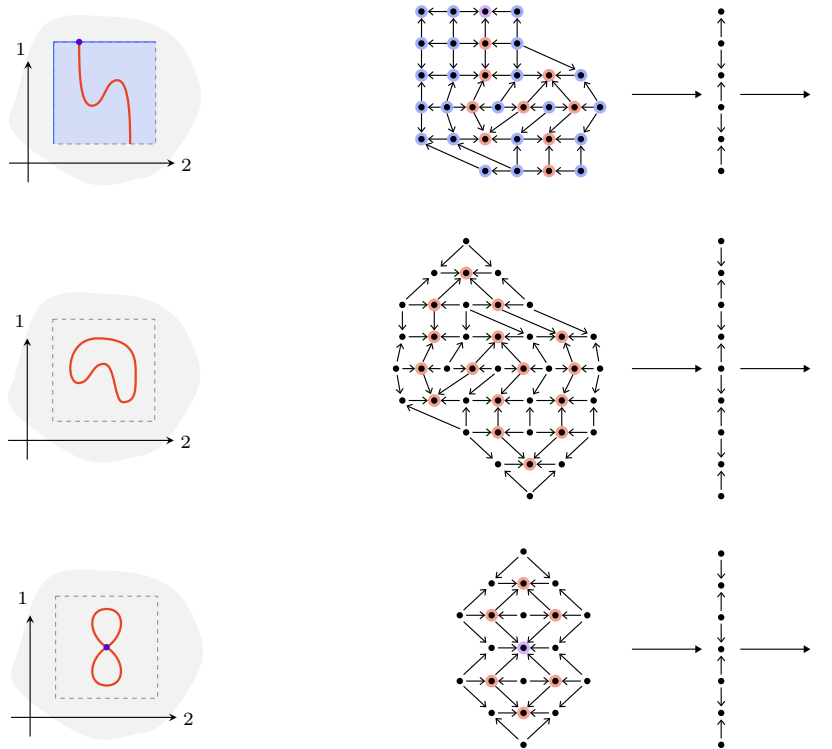

FIGURE 5.31. Normalized stratified trusses classifying 2-tame stratifications and embeddings.

EXAMPLE 5.3.35 (Classifying 3-tame stratifications). In [Figure 5.32](#), we depict a 3-tame stratification and its classifying normalized stratified 3-truss.

The 3-mesh corresponding to the underlying unstratified 3-truss was shown in Figure 4.1. ┌

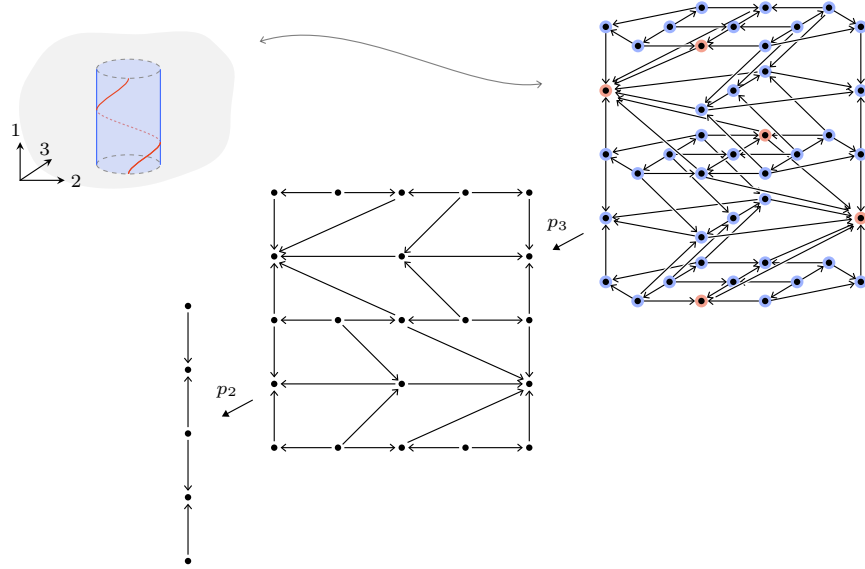

FIGURE 5.32. The normalized stratified truss of a 3-tame stratification.

EXAMPLE 5.3.36 (Classifying 3-tame embeddings). In Figure 5.33, we depict a 3-tame embedding (namely the braid isotopy) and its classifying normalized ambient stratified truss. The 3-mesh corresponding to the underlying unstratified 3-truss was shown on the left in Figure 4.16.

Earlier, in Figure 5.22, we depicted another 3-tame embedding (namely the cusp singularity) and its classifying normalized ambient stratified 3-truss. The 3-mesh corresponding to the underlying unstratified 3-truss was shown earlier in Figure 4.15. ┌

5.3.1.5. Tame stratified bundles. We next discuss the combinatorial classification of *bundles* of tame stratifications.

Recall that a stratified bundle is a stratified map that is a locally trivial bundle within each base stratum. We will need the following fiberwise framed version of that notion.

TERMINOLOGY 5.3.37 (Framed stratified bundles). Consider a stratified map $q : (Z, f) \rightarrow (B, g)$ with a realization (i.e. a base-preserving embedding) into the trivial bundle $B \times \mathbb{R}^n \rightarrow B$. The map q is a ‘framed stratified bundle’ if for each stratum s of the base g and for each point $x \in s$ there is an open neighborhood $x \in U \subset s$, and a stratification $(F \subset \mathbb{R}^n, h)$, such that the restriction $(q^{-1}(U), f) \rightarrow U$ is framed bundle isomorphic (i.e. the bundle isomorphism is a fiberwise framed map) to the trivial bundle with fiber (F, h) . ┌

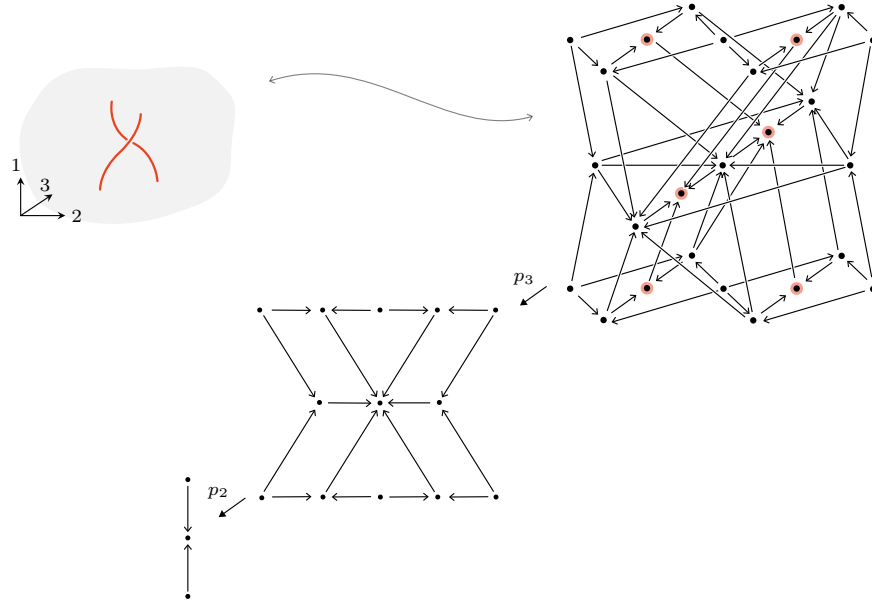

FIGURE 5.33. The normalized ambient stratified truss of the braid.

Of course any framed stratified bundle is, in particular, a stratified bundle. It will be convenient, and without conceptual consequence, to restrict attention to the case where the realizing map is a subspace inclusion, i.e. to assume $Z \subset B \times \mathbb{R}^n$.

DEFINITION 5.3.38 (Tame stratified bundles). Let (B, g) be a stratification, together with a cellulation (B, c) . An n -tame stratified bundle over the base cellulation $c \rightarrow g$ is a framed stratified bundle $q : (Z, f) \rightarrow (B, g)$, for which there exists an n -mesh bundle over the cellulated base (B, c) , which refines the total stratification of the bundle. (That is, there is an n -mesh bundle M with support $\gamma(M) = Z$, whose realization $\gamma : (M_n, f_n) \rightarrow (Z, f)$ is a coarsening.)

Assuming the base (B, g) is sufficiently nice (so in particular cellulable), the proofs of Theorem 5.2.23 and Proposition 5.2.25 concerning coarsest meshes carry over (using Lemma 5.2.19 in place of Key Lemma 5.2.13) to the case of coarsest mesh bundles. That generalization yields the following result.

THEOREM 5.3.39 (Coarsest refining mesh bundles). For a sufficiently nice base stratification (B, g) with a fixed cellulation (B, c) , every tame stratified bundle (Z, f) over the cellulation $c \rightarrow g$ has a unique coarsest refining mesh bundle over the cellulated base (B, c) . Moreover, every stratified bundle homeomorphism of tame stratified bundles preserves this coarsest refining mesh bundle. \square

We now consider the combinatorial counterpart of tame stratified bundles with their coarsest refining mesh bundles. Recall that we defined a stratified truss to be simply a labeled truss, and a normalized stratified truss to be one that admits no label-preserving truss coarsening. In the bundle case, we must adopt a different formulation, to account for the combinatorial analog of the base cellulation, as follows.

DEFINITION 5.3.40 (Normalized labeled truss bundles). A labeled n -truss bundle p is **normalized** if any label-preserving and base-preserving truss bundle coarsening (of p) is the identity. \square

DEFINITION 5.3.41 (Stratified n -truss bundles). Let P be a poset, together with a connected quotient map of posets $\phi : Q \rightarrow P$. A **stratified n -truss bundle** over the poset quotient $Q \rightarrow P$ is a labeled n -truss bundle p over the poset Q , whose labeling lbl_p is a connected-quotient map, such that for each preimage $U := \phi^{-1}(x \in P) \subset Q$, the restricted bundle $p|_U$ normalizes to a constant labeled truss bundle. \square

For a sufficiently nice base stratification (B, g) , together with a cellulation (B, c) , we can thus consider stratified truss bundles over the fundamental poset quotient $\mathbb{I}c \rightarrow \mathbb{I}g$.

The classification of tame bundles can now proceed as follows.

THEOREM 5.3.42 (Classification of tame stratified bundles). *Let (B, g) be a sufficiently nice stratification, together with a cellulation (B, c) . Framed stratified bundle homeomorphism classes of n -tame stratified bundles over the cellulation $c \rightarrow g$ are in correspondence with base-preserving isomorphism classes of normalized stratified n -truss bundles over the fundamental poset quotient $\mathbb{I}c \rightarrow \mathbb{I}g$.*

PROOF. The proof is analogous to that of [Theorem 5.1.23](#), using now the fundamental truss bundle construction and the mesh bundle realization construction: from a tame stratified bundle, take the coarsest refining mesh bundle, and form its fundamental truss bundle together with the evident stratification; from a normalized stratified truss bundle, take its mesh bundle realization together with again the evident stratification. \square

REMARK 5.3.43 (Tame bundle embeddings). As we have generalized tame stratifications to the bundle case, we may generalize tame embeddings to the bundle case, as follows. A ‘tame bundle embedding’ of a stratified bundle $q : (W, h) \rightarrow (B, g)$ is an embedding $\iota : W \hookrightarrow B \times \mathbb{R}^n$, whose stratified image extends (constructibly) to an open neighborhood stratification that is a tame stratified bundle.

The classification of tame embeddings generalizes accordingly: minimal coarsest refining mesh bundles always exist, and as a consequence tame bundle embeddings (over cellulated bases) are classified (up to framed stratified bundle isomorphism) by normalized ambient stratified truss bundles (over the corresponding fundamental poset quotient) (up to bundle isomorphism). \square

EXAMPLE 5.3.44 (Classification of tame stratified bundles and tame bundle embeddings). In Figure 5.34, on the left we depict a 1-tame stratified bundle (Z, f) over a stratified circle (B, g) with cellulation (B, c) , and a 1-tame bundle embedding ι of a stratified bundle $(W, h) \rightarrow (B, g)$. On the right, we depict the corresponding normalized stratified 1-truss bundle and normalized ambient stratified 1-truss bundle, respectively. \square

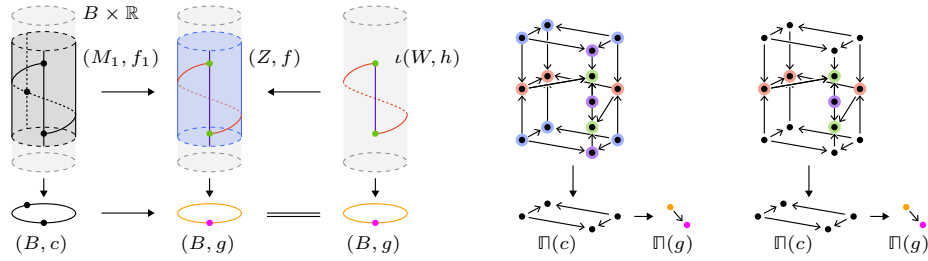

FIGURE 5.34. Tame stratified bundles and tame bundle embeddings with their corresponding normalized stratified truss bundles.

5.3.2. Polyhedrality.

SYNOPSIS. We introduce polyhedral stratifications as the constructible substratifications of coarsenings of simplicial stratifications of polyhedra; we then prove that any closed or open tame stratification is framed stratified homeomorphic to a polyhedral stratification, that any tame embedding is framed stratified homeomorphic to a tame embedding whose image is a polyhedral stratification, and that any polyhedral stratification is the image of a tame embedding. We recall the failure of the classical Hauptvermutung, that any homeomorphism is homotopic to a piecewise linear homeomorphism, and similarly of the ambient Hauptvermutung, and then prove by contrast the framed stratified Hauptvermutung, that any framed stratified homeomorphism of polyhedral stratifications is homotopic to a piecewise linear homeomorphism.

5.3.2.1. Tameness and polyhedral stratifications. As a first application of the combinatorializability of tame stratifications, we will now see that (closed or open) tame stratifications are *polyhedral*, in the sense of being constructible substratifications of coarsenings of linear realizations of simplicial complexes, and conversely polyhedral stratifications are tame embeddings.

TERMINOLOGY 5.3.45 (Linear realizations and polyhedra). A ‘linear realization’ of a finite simplicial complex K is an embedding $\iota : |K| \hookrightarrow \mathbb{R}^n$ that is linear on each simplex. The image $\iota(|K|) \subset \mathbb{R}^n$ of a linear realization is called a ‘polyhedron’ (see [RS72, Defn. 1.1]). \square

Henceforth we assume all simplicial complexes are finite, without comment. For convenience, we often suppress the embedding ι of a linear realization, and informally consider the complex as being a subspace of euclidean space.

Note that given a linear realization of a complex, its image has a stratification by the open simplices of the complex; we refer to that as a ‘simplicial stratification’ of the polyhedron. By a ‘compact polyhedral stratification’ we will mean any coarsening of a simplicial stratification of a polyhedron. More generally, we may take constructible substratifications of compact polyhedral stratifications, as follows.

DEFINITION 5.3.46 (Polyhedral stratifications). A **polyhedral stratification** is a stratification (Z, f) of a euclidean subspace $Z \subset \mathbb{R}^n$, that is a constructible substratification of a coarsening of a simplicial stratification of a polyhedron. —

Note that, though a polyhedron is always compact, the support Z of a polyhedral stratification may certainly be non-compact.

As a corollary of the combinatorializability of tame stratifications, we may now prove that both closed and open tame stratifications are framed stratified homeomorphic to polyhedral stratifications.

PROOF OF COROLLARY 5.1.25. Given a closed tame stratification (Z, f) , consider its coarsest refining mesh M . By the proof of [Theorem 5.1.23](#), this tame stratification is framed stratified homeomorphic to the stratified mesh realization $\|\mathbb{P}_\top(M, f)\|_{\text{str}}$ of the stratified fundamental truss $\mathbb{P}_\top(M, f)$. That realization is a compact polyhedral stratification by construction (see [Construction 4.2.47](#) and [Definition 5.3.26](#)).

Given instead an open tame stratification (Z, f) , consider again the coarsest refining mesh M and stratified fundamental truss $\mathbb{P}_\top(M, f) = (\mathbb{P}_\top M, \mathbb{P}_{|\text{bl}}(M, f))$. Extend the stratification $\mathbb{P}_{|\text{bl}}(M, f) : \mathbb{P}(f_n) \rightarrow \mathbb{P}f$ to a stratification $(\mathbb{P}_{|\text{bl}}(M, f))_+ : (\overline{\mathbb{P}_\top M})_n \rightarrow (\mathbb{P}f)_+$ on the cubical compactification $\overline{\mathbb{P}_\top M}$, which restricts to the given stratification on $\mathbb{P}(f_n)$ and merges the complement $(\overline{\mathbb{P}_\top M})_n \setminus \mathbb{P}(f_n)$ into a single new stratum. The original tame stratification is framed stratified homeomorphic to the realization $\|\mathbb{P}_\top(M, f)\|_{\text{str}}$, which is a constructible substratification of the compact polyhedral stratification $\|(\overline{\mathbb{P}_\top M}, (\mathbb{P}_{|\text{bl}}(M, f))_+)\|_{\text{str}}$, as required (see [Construction 4.2.52](#) and again [Definition 5.3.26](#)). □

Having addressed the polyhedrality of closed and open tame stratifications, we may consider more generally the polyhedrality of tame embeddings. Recall that the tameness of a tame embedding is controlled by the existence of a tame open neighborhood, i.e. an open tame stratification having the stratified embedding as a constructible substratification. In particular, the natural equivalence relation on tame embeddings is framed stratified homeomorphism, which by definition (see [Terminology 5.1.16](#) and [Terminology 5.1.17](#)) is a framed map of tame open neighborhoods that is a homeomorphism and

restricts to a stratified homeomorphism of the embeddings. With that notion in mind, we may formulate the desired polyhedrality statement.

PROPOSITION 5.3.47 (Tame embeddings are polyhedral). *Any tame embedding is framed stratified homeomorphic to a tame embedding whose stratified image is a polyhedral stratification.*

PROOF. Given a tame embedding ι of the stratified space (W, g) , pick a tame open neighborhood Z of the embedding and a tame stratification (Z, f) of that neighborhood (which by definition has the image $\iota(W, g)$ as a constructible substratification). By [Corollary 5.1.25](#), there is a framed stratified homeomorphism $F : (Z, f) \cong (Z', f')$ to a polyhedral stratification; the composite $F \circ \iota$ is the desired tame embedding, framed stratified homeomorphic to the embedding ι and having polyhedral image. \square

We now show conversely that every polyhedral stratification is the image of a tame embedding. We will use the following observation and construction.

OBSERVATION 5.3.48 (Image refinements). Let K be a finite simplicial complex, and $F : |K| \rightarrow \mathbb{R}^n$ a (not-necessarily injective) simplex-wise linear map. There exists a simplicial complex L (considered as a subspace of \mathbb{R}^n) such that $\text{im}(F) = |L|$, and, for each simplex $x \in K$, the image $F(|x|)$ is a union of simplices $|y|$, with $y \in L$ (see [\[RS72, Thm. 2.15\]](#)). We call the simplicial complex L an ‘image refinement’ of the map F . \square

CONSTRUCTION 5.3.49 (Refining meshes of linearly realized complexes). Let K be a simplicial complex with a linear realization $\iota : |K| \hookrightarrow \mathbb{R}^n$. We will construct an open n -mesh M that refines the realization in the sense of [Terminology 5.2.27](#). For brevity, we will let the realization embedding ι be implicit, consider the complex as a subspace of euclidean space, suppress the geometric realization from our notation, and refer to the mesh simply as ‘refining the complex’ K .

Using [Observation 5.3.48](#), take an image refinement L for the projection $\pi_n : K \rightarrow \mathbb{R}^{n-1}$. By induction, construct an $(n-1)$ -mesh $M_{<n}$ that refines L . Next, refine the complex K to a stratification \tilde{K} such that $\pi_n : \tilde{K} \rightarrow (M_{n-1}, f_{n-1})$ is a stratified bundle. (Specifically, take \tilde{K} to be the refinement of K whose strata are the connected components of the spaces $\pi_n^{-1}(s) \cap r$, for s and r being the strata of f_{n-1} and K respectively.) Extend the stratification \tilde{K} to an open 1-mesh bundle $p_n : (M_n, f_n) \rightarrow (M_{n-1}, f_{n-1})$ such that $\tilde{K} \hookrightarrow (M_n, f_n)$ is a constructible substratification. Augmenting $M_{<n}$ with the bundle p_n provides the required mesh M refining the complex K . \square

EXAMPLE 5.3.50 (Mesh refinements of linear complexes). In [Figure 5.35](#), we depict the inductive procedure, given in the previous construction, for producing a mesh refinement of a linearly realized simplicial complex. Specifically, on the top left is a realized simplicial complex K , which projects to a complex $\pi_3 K$ refined by the complex L in the lower left. That complex in

turn has the mesh refinement shown in the lower right. In the upper right, we do not draw the whole stratification (M_3, f_3) but just the fibers of the 1-mesh bundle $(M_3, f_3) \rightarrow (M_2, f_2)$ over the point strata of f_2 , along with the constructible substratification \tilde{K} . —

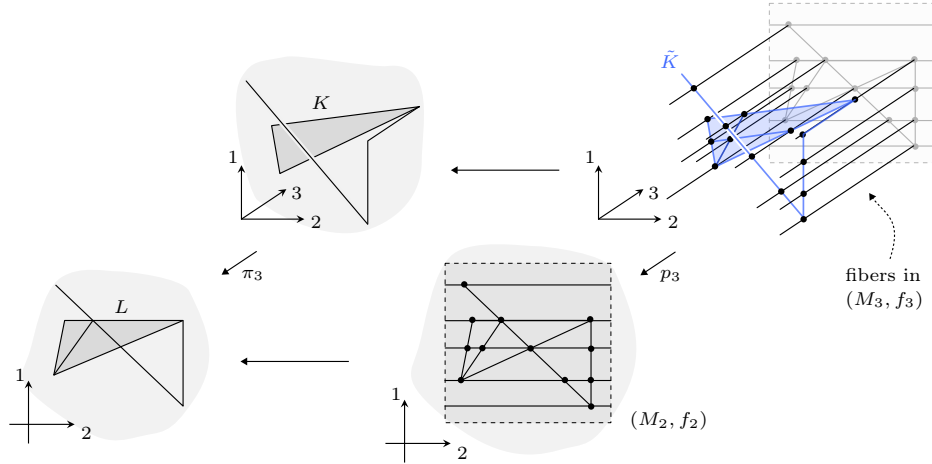

FIGURE 5.35. Inductive construction of mesh refinements for polyhedral stratifications.

We can now record the proof that every polyhedral stratification is the image of a tame embedding.

PROOF OF PROPOSITION 5.1.26. Let (Z, f) be a compact polyhedral stratification. Let K be a linearly realized simplicial complex whose simplicial stratification coarsens to the stratification (Z, f) . By **Construction 5.3.49**, there is a stratification \tilde{K} refining the simplicial stratification K , and an open n -mesh $M = \{(M_i, f_i)\}$ having \tilde{K} as a constructible substratification. (That is just another way to say that the mesh refines the complex, in the sense that every stratum of the complex is a union of mesh strata.) Consider the composite coarsening $\tilde{K} \rightarrow K \rightarrow f$ and the closed constructible substratification $\tilde{K} \hookrightarrow f_n$. The pushout of $f \leftarrow \tilde{K} \hookrightarrow f_n$ is a stratification g with a coarsening $f_n \rightarrow g$ and a constructible substratification $f \hookrightarrow g$. By construction, the stratification g is tame, and so f is a tame embedding, as desired. Finally, when (Z, f) is a non-necessarily compact polyhedral stratification, then by definition it is a constructible substratification of a compact polyhedral stratification, and is therefore also a tame embedding. □

The above relationship between tame and polyhedral stratifications makes, of course, crucial use of the linear structure of mesh realizations of trusses. For later use we record the following terminology and observation concerning that linear structure.

TERMINOLOGY 5.3.51 (Linear meshes). A mesh M is called ‘linear’ if there is a mesh isomorphism $\|\mathbb{T}M\|_{\mathbb{M}} \cong M$ that is linear on each open simplex of the mesh realization $\|\mathbb{T}M\|_{\mathbb{M}}$ of the fundamental truss $\mathbb{T}M$. \square

OBSERVATION 5.3.52 (Linear refining meshes of linearly realized complexes). Every linearly realized simplicial complex (and thus every polyhedral stratification) has a linear refining n -mesh (again in the sense of Terminology 5.2.27). This follows by the method of Construction 5.3.49, by inductively choosing the $(n - 1)$ -mesh $M_{<n}$ to be linear, and then choosing the 1-mesh bundle p_n such that the augmented n -mesh M is again linear. \square

5.3.2.2. The framed Hauptvermutung. As a second application of the combinatorializability of tame stratifications, we will now prove that every framed stratified homeomorphism is homotopic to a piecewise linear framed stratified homeomorphism, which is to say we prove a framed stratified Hauptvermutung.

We begin with a recollection of the classical Hauptvermutung (see, for example, [RCS⁺96]).

DISPROVEN CONJECTURE 5.3.53 (Hauptvermutung). *Any homeomorphism between polyhedra is homotopic to a piecewise linear homeomorphism.*

A concise counterexample is the following: the double suspension of the Poincaré homology sphere is homeomorphic to the 5-sphere [Can79, Edw06] but not piecewise linearly homeomorphic to it.

This polyhedral Hauptvermutung was the most quixotic and famous effort to exert some combinatorial control over general topological phenomena. While confirmed for manifolds of dimension at most 3 [Moi52], in higher dimensions reality intervened:

- › The failure of the Hauptvermutung was ensured by the intrinsic ‘wildness’ of some topological homeomorphisms and of some topological spaces themselves: not only are there homeomorphisms of polyhedra not homotopic to PL homeomorphisms [Mil61], but there are homeomorphic polyhedra that are not PL homeomorphic at all.
- › Restricting to manifolds could not salvage matters; the manifold Hauptvermutung fails similarly [KS69]: there are homeomorphisms of PL manifolds that are not homotopic to PL homeomorphisms, and even homeomorphic PL manifolds that are not PL homeomorphic at all.
- › Yet worse, the combinatorial triangulation conjecture fails [KS77]: there are closed topological manifolds that admit no PL structure whatsoever, i.e. are not homeomorphic to any PL manifold.
- › And in the terminal collapse of even the weakest fantasy of topological combinatorializability, the simplicial triangulation conjecture also fails [Man16]: there are closed topological manifolds that admit no triangulation, i.e. are not homeomorphic to any simplicial complex.

What one does with this succession of dashed dreams is a matter of penchant and perspective. One can dismiss the wildness, retreating to

consideration of smooth or piecewise linear manifolds; one can embrace the wildness, classifying topological manifolds as such; or, in contrarian fashion, one can excise the wild phenomena and hope the remaining *topologie modérée* is sufficiently general, sufficiently computable, and, ideally, entirely combinatorial. Of course we take this third, tame path; and of course we take tameness to be of the sort provided by a (tame) framed stratification.

We will presently be giving the proof of the framed stratified Hauptvermutung, i.e. that any framed stratified homeomorphism between polyhedral stratifications is homotopic to a framed stratified piecewise linear homeomorphism. Recall that a polyhedral stratification is in particular a tame embedding, and a framed stratified homeomorphism of a tame embedding is, by definition, a framed stratified homeomorphism of a tame open neighborhood. In that sense, the framed stratified Hauptvermutung is implicitly a statement about *ambient* homeomorphisms, i.e. homeomorphisms of open neighborhoods in euclidean space. One might worry that the failure of the classical Hauptvermutung and success of the framed Hauptvermutung is actually due, not to the framing, but to the ambient nature of the latter claim. That is not the case; we record the classical ambient Hauptvermutung as follows.

DISPROVEN CONJECTURE 5.3.54 (Ambient Hauptvermutung). *Any ambient homeomorphism between polyhedra is ambient homotopic to a piecewise linear ambient homeomorphism.*

A counterexample here is more involved, and may be obtained as follows.⁴² Take two PL 5-manifolds that are homeomorphic to the 5-torus but not PL homeomorphic to one another; embed them locally flatly in \mathbb{R}^{10} , and then include into \mathbb{R}^{12} ; those embeddings are (compactly supported) ambient isotopic and in particular ambient homeomorphic; but of course they are not even PL homeomorphic much less PL ambient homeomorphic.

Of course, that statement is a special case of the corresponding stratified statement, whose failure follows immediately.

DISPROVEN CONJECTURE 5.3.55 (Ambient stratified Hauptvermutung). *Any ambient stratified homeomorphism between polyhedral stratifications is ambient stratified homotopic to an ambient stratified piecewise linear homeomorphism.*

We record this stratified version explicitly for comparison: the framed Hauptvermutung is obtained by adding ‘framed’ before ‘stratified’ and removing ‘ambient’ simply as implicit. Having perambulated sufficiently, we now established the framed result.

PROOF OF THEOREM 5.1.27. Let (Z, f) and (W, g) be polyhedral stratifications, and let $F : (Z, f) \cong (W, g)$ be a framed stratified homeomorphism (of tame embeddings) between them. By definition, the framed stratified

⁴²We are grateful to Mark Powell for outlining this example for us.

homeomorphism F is given, for some tame open neighborhoods $\tilde{U} \supset Z$ and $\tilde{V} \supset W$, by a framed map $\tilde{U} \cong \tilde{V}$ that is a homeomorphism and restricts to a stratified homeomorphism $f \cong g$. Shrink the tame open neighborhood \tilde{U} to $U \subset \tilde{U}$, so that there is a minimal coarsest refining mesh Q_f of the tame embedding (Z, f) with support U . Note that the image $Q_g := FQ_f$ is a minimal coarsest refining mesh of the embedding (W, g) with support $V := FU \subset \tilde{V}$.

By [Observation 5.3.52](#) and the method of [Construction 5.3.49](#), we may construct a linear open n -mesh M that refines the polyhedral stratification (Z, f) and has support U , and similarly linear mesh N refining (W, g) with support V . Consider the fundamental trusses $T := \mathbb{P}_\top M$ and $S := \mathbb{P}_\top N$, and pick mesh isomorphisms $\|T\|_M \cong M$ and $\|S\|_M \cong N$ that are linear on each simplex. Let $R_f := \mathbb{P}_\top Q_f$ and $R_g := \mathbb{P}_\top Q_g$ be the fundamental trusses of the minimal coarsest meshes. Since Q_f cannot be coarsened, there is a coarsening $M \rightarrow Q_f$ and therefore a truss coarsening $T \rightarrow R_f$; similarly there is a truss coarsening $S \rightarrow R_g$. Using [Construction 4.2.78](#), realize those truss coarsenings to mesh coarsenings that are linear on each simplex. Finally take a piecewise linear mesh realization of the truss isomorphism $\mathbb{P}_\top F : \mathbb{P}_\top Q_f \rightarrow \mathbb{P}_\top Q_g$. Altogether we have the series of piecewise linear homeomorphisms in the top row of the following diagram:

$$\begin{array}{ccccccc}
 (M_n, f_n) & \leftarrow & \|T_n\|_M & \rightarrow & \|(R_f)_n\|_M & \rightarrow & \|(R_g)_n\|_M & \leftarrow & \|S_n\|_M & \rightarrow & (N_n, g_n) \\
 \downarrow & & & & & & & & & & \downarrow \\
 (U, f_+) & \xrightarrow{\hspace{10em} G \hspace{10em}} & & & & & & & & & (V, g_+)
 \end{array}$$

Recall from [Remark 5.2.26](#) the canonical tame stratifications (U, f_+) and (V, g_+) associated to the tame embeddings (Z, f) and (W, g) respectively. The vertical maps are mesh refinements of those stratifications. Define the piecewise linear homeomorphism $G : U \rightarrow V$ as the indicated zig-zag composite. Observe that the map G is in fact a framed stratified map $G : (U, f_+) \rightarrow (V, g_+)$ of tame stratifications, and therefore by definition a framed stratified map $G : (Z, f) \rightarrow (W, g)$ of tame embeddings.

It remains only to check that F and G are framed stratified homotopic (as framed stratified maps of tame embeddings); that means that there is a family of framed maps from a tame neighborhood U to a tame neighborhood V , which is at every moment a stratified map from (Z, f) to (W, g) . In fact, we will have a family that is moreover constant on fundamental posets. Observe that the maps $F : U \rightarrow V$ and $G : U \rightarrow V$ induce n -mesh maps $F_M : Q_f \rightarrow Q_g$ and $G_M : Q_f \rightarrow Q_g$ of the minimal coarsest meshes of the embeddings, and the resulting fundamental truss maps are equal: $\mathbb{P}_\top F_M = \mathbb{P}_\top G_M : R_f \rightarrow R_g$. By the weak faithfulness of the fundamental truss functor, it follows that there is a homotopy of mesh maps $F_M \sim G_M$ (in fact up to contractible choice, a unique such homotopy); that homotopy of mesh maps provides

a homotopy of framed stratified maps $F \sim G : (U, f_+) \rightarrow (V, g_+)$, which suffices. \square

REMARK 5.3.56 (All triangulations are equivalent). Consider a fixed polyhedral stratification (Z, f) and two different triangulations of it, i.e. two (linearly realized) simplicial complexes K and L for which the stratification (Z, f) is a constructible substratification of a coarsening of the simplicial stratifications of the complexes K and L . (If the polyhedral stratification is just an ordinary polyhedron, this is just the ordinary naive notion of triangulation.) Consider the preceding proof, in the case where the stratifications are identical, $(Z, f) = (W, g)$, and the homeomorphism is the identity, $F = \text{id}$, and pick the meshes M and N to refine the complexes K and L , respectively; the conclusion is that the identity is homotopic to a piecewise linear homeomorphism between the triangulations, and so perforce the triangulations are piecewise linearly equivalent. This does not contravene the invalidity of the classical Hauptvermutung, but articulates it: the problem is not the existence of exotic combinatorial subdivisions, but of wild, infinitary homeomorphisms. —

REMARK 5.3.57 (Contractibility of framed structure groups). In an informal sense, we may distill the differential veracity of the unframed and framed Hauptvermutung to the following discrepancy. The classical automorphism groups $\text{Aut}_{\text{TOP}}(\mathbb{R}^n)$ and $\text{Aut}_{\text{PL}}(\mathbb{R}^n)$ have different homotopy types, but the framed automorphism groups $\text{Aut}_{\text{TOP}}^{\text{fr}}(\mathbb{R}^n)$ and $\text{Aut}_{\text{PL}}^{\text{fr}}(\mathbb{R}^n)$ (see Definition 4.1.86) are both contractible and in particular homotopy equivalent. —

REMARK 5.3.58 (Framed combinatorial topology and o-minimal geometry). Recall that the most well-established approach to Grothendieck's vision for tame topology is via model theory, specifically o-minimality [VdD98, Cos99]. Roughly, a class of subsets of euclidean spaces forms an o-minimal structure if

- (1) it is closed under finite union, finite intersection, and complement,
- (2) it is closed under product and standard projection, and
- (3) the subsets of 1-dimensional euclidean space are the finite unions of open intervals and points.

Basic examples of classes include semilinear sets (i.e. polyhedra) and semialgebraic sets. More geometrically serious examples include those classes definable with analytic functions, exponential functions, or both [vdD86, Wil96, vdDMM94].

Framed combinatorial topology and o-minimal geometry share the goal of providing a tame class of euclidean structures, and they share the insight that a tame class should be controlled by its finitary simplicity in dimension 1 and by being well behaved under standard projection. However, beyond that, these approaches are conceptually, technically, and practically orthogonal:

- › Conceptually orthogonal in the sense that o-minimal geometry *axiomatizes* a suitable class of tame subsets, while framed combinatorial topology *constructs* a suitable class of tame subsets.
- › Technically orthogonal in the sense that o-minimal classes are constrained by the insistence on *closure* under finite union and intersection, while framed combinatorial classes are constrained by the insistence on *constructibility* of their projections.
- › Practically orthogonal in the sense that any nontrivial o-minimal class contains subsets that are not framed constructible (for instance the surface in Figure 4.11 is semialgebraic), while there are framed constructible subsets not contained in any o-minimal class (for instance the tame embedding in Figure 5.6 is o-minimally verboten). —

5.3.3. Computability.

SYNOPSIS. We prove that stratified truss coarsening is confluent in the sense that all chains of such coarsenings end in the same normalized truss, and as a consequence establish that coarsest mesh refinements are computable and framed stratified homeomorphism of tame stratifications is decidable. We introduce the dual notions of tame cells and tame singularities as elementary closed and open components of tame stratifications, and observe that the confluence of stratified truss coarsenings dualizes to a confluence of stratified truss degeneracies. Extending attention beyond tame and embedded stratifications, we show that n -directed acyclic graphs have canonical coarsest cell structures, and observe therefore that framed homeomorphism of such graphs is decidable.

5.3.3.1. Normal forms and framed stratified homeomorphism. Our next applications concern the computability properties of tame stratifications. Specifically, we will show that from a refining mesh of a tame stratification, one can algorithmically determine a coarsest refining mesh; from there we will deduce that, given refining meshes of two tame stratifications, one can algorithmically determine whether the stratifications are framed stratified homeomorphic. Of course, both decision procedures will operate, roughly, by translating the problem (via a fundamental truss functor) to a corresponding truss problem, applying a combinatorial algorithm there, and then translating (by a mesh realization functor) back to a geometric context.

We begin by setting up the relevant truss algorithms. The crucial property is that stratified truss coarsening is *confluent*, in the sense that every series of iterated truss coarsenings eventually ends in the same normalized stratified truss.

PROPOSITION 5.3.59 (Stratified truss coarsening is confluent). *Let T be a stratified n -truss. Every maximal chain of non-identity truss coarsenings, beginning with T , ends in the same normalized n -truss $\llbracket T \rrbracket$. Furthermore, there is a unique truss coarsening $T \rightarrow \llbracket T \rrbracket$.*

An equivalent formulation is the following: for a stratified n -truss T , there is a unique normalized stratified n -truss $\llbracket T \rrbracket$ with a truss coarsening $T \rightarrow \llbracket T \rrbracket$, and there is a unique such coarsening.

TERMINOLOGY 5.3.60 (Normal forms of stratified trusses). For a stratified truss T , the normalized stratified truss $\llbracket T \rrbracket$ having a truss coarsening $T \rightarrow \llbracket T \rrbracket$, is called the **normal form** of the stratified truss T . —

PROOF OF PROPOSITION 5.3.59. Let $F^{(1)} : T \rightarrow T^{(1)}$ and $F^{(2)} : T \rightarrow T^{(2)}$ be non-identity truss coarsenings of the stratified truss T . The underlying unstratified truss maps $\underline{F}^{(i)} : \underline{T} \rightarrow \underline{T}^{(i)}$ are coarsenings of the truss \underline{T} . By Construction 4.2.78, we may form the mesh coarsening realizations $\|\underline{F}^{(i)}\|_{\mathbb{M}}^{\text{crs}} : \|\underline{T}\|_{\mathbb{M}} \rightarrow \|\underline{T}^{(i)}\|_{\mathbb{M}}$. By modifying $\|\underline{T}^{(i)}\|_{\mathbb{M}}$ and the realization maps if need be, we may assume that $\|\underline{T}^{(i)}\|_{\mathbb{M}}$ and $\|\underline{T}\|_{\mathbb{M}}$ all have the same support in \mathbb{R}^n , and that the mesh coarsenings are identities on underlying spaces.

Now form the stratified mesh realization $(\|\underline{T}\|_{\mathbb{M}}, \|T\|_{\text{str}})$ of the stratified truss T . Since the maps $F^{(1)}$ and $F^{(2)}$ are truss coarsenings of stratified trusses, both mesh realizations $\|\underline{T}^{(1)}\|_{\mathbb{M}}$ and $\|\underline{T}^{(2)}\|_{\mathbb{M}}$ refine the stratification $\|T\|_{\text{str}}$. By Key Lemma 5.2.13, we may take the mesh join $\|\underline{T}^{(1)}\|_{\mathbb{M}} \vee \|\underline{T}^{(2)}\|_{\mathbb{M}}$, which of course still refines the stratification $\|T\|_{\text{str}}$. Take the fundamental stratified truss $S := \mathbb{T}_{\mathbb{T}}(\|\underline{T}^{(1)}\|_{\mathbb{M}} \vee \|\underline{T}^{(2)}\|_{\mathbb{M}}, \|T\|_{\text{str}})$, and observe that we have a diagram of truss coarsenings:

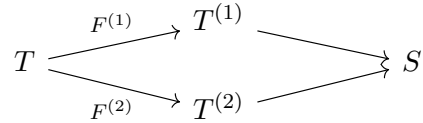

It follows that there cannot be two maximal chains of truss coarsenings ending in distinct stratified trusses, and of course the end of any chain is a normalized stratified truss, which we may denote $\llbracket T \rrbracket$. Furthermore, if there were two distinct truss coarsenings $F^{(1)}$ and $F^{(2)}$ from T to its normal form $\llbracket T \rrbracket$, the above argument and resulting diagram (for those coarsenings) contradicts the fact that $\llbracket T \rrbracket$ is normalized. □

EXAMPLE 5.3.61 (Confluence of truss coarsenings). In Figure 5.36, we depict two truss coarsenings F and G of a stratified 2-truss. The procedure in the preceding proof produces the further coarsenings F' and G' to the same stratified 2-truss. We leave the projections of the trusses implicit, and note that the composite truss coarsening $F' \circ F = G' \circ G$ is the one previously shown in Figure 5.26. —

REMARK 5.3.62 (Mesh joins as truss pushouts). Though the given proof of Proposition 5.3.59 leans heavily on our earlier construction of mesh joins, one could instead prove the confluence of truss coarsening in purely combinatorial terms.

Consider the diamond of truss coarsenings of stratified trusses constructed in that proof. The induced diagram of coarsenings of underlying trusses is a

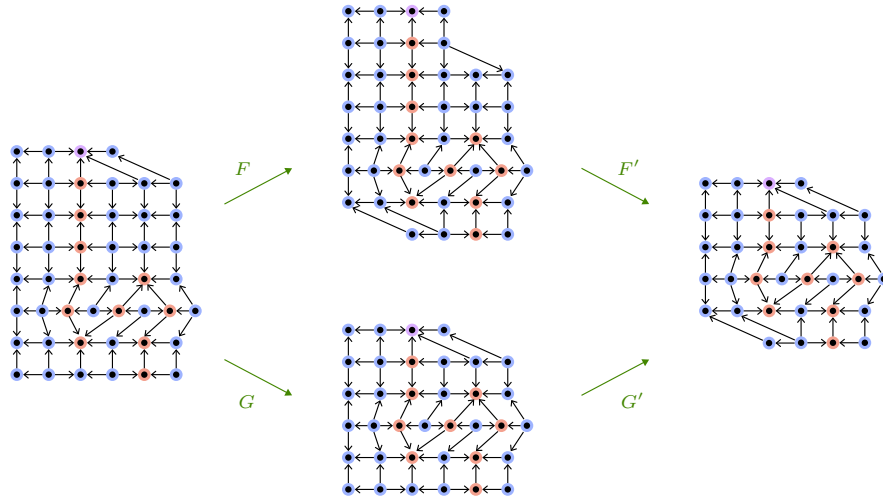

FIGURE 5.36. Confluence of truss coarsenings.

pushout in the category $\text{Trs}_n^{\text{crs}}$ of n -trusses and their coarsenings. Note that pushout is preserved by the total poset functor $(-)_n : \text{Trs}_n^{\text{crs}} \rightarrow \text{Pos}$, and is also preserved by the truncation functor $(-)_{<n} : \text{Trs}_n^{\text{crs}} \rightarrow \text{Trs}_{n-1}^{\text{crs}}$.

To produce a combinatorial proof, then, it suffices to construct that pushout of truss coarsenings directly. As one could bet on, that construction would proceed inductively, with an inductive step involving 1-truss bundle pushouts whose existence is less more straightforward (than the mesh case) than one would hope. —

The preceding discussion generalizes to the case of stratified truss bundles, relying of course on Theorem 5.3.39 and Theorem 5.3.42. We summarize the bundle case as follows.

OBSERVATION 5.3.63 (Normal forms of stratified truss bundles). Consider a stratified truss bundle p over a base poset B . Every maximal chain of base-preserving and label-preserving non-identity truss bundle coarsenings, beginning with p , ends in the same normalized truss bundle $\llbracket p \rrbracket$, and the truss bundle coarsening $p \rightarrow \llbracket p \rrbracket$ is unique. The bundle $\llbracket p \rrbracket$ is called the ‘normal form’ of the truss bundle p . —

Equipped with the confluence of truss coarsenings, it is certainly algorithmic to find the normal form of a stratified truss, as follows.

OBSERVATION 5.3.64 (Normal forms are computable). Given a stratified n -truss T , there is a finite set of surjective n -truss maps $F : T \rightarrow S$, thus of coarsenings of n -trusses, thus of label-preserving coarsenings i.e. truss coarsenings. Search that set of truss coarsenings for the one with the smallest codomain, and note that is the truss coarsening $T \rightarrow \llbracket T \rrbracket$ to the normal form. —

REMARK 5.3.65 (Normal forms are efficiently computable). Of course there are better algorithms for computing normal forms than the preceding brute-force search. For instance, we can take an inductive approach, sketched as follows.

Given a stratified n -truss $T := (\underline{T}, \text{lbl}_T)$, we will first normalize just the stratified 1-truss bundle $(p_n : T_n \rightarrow T_{n-1}, \text{lbl}_T)$ (see Observation 5.3.63); abusively abbreviate the resulting normal form bundle $\tilde{p}_n \equiv (\tilde{p}_n : \tilde{T}_n \rightarrow T_{n-1}, \text{lbl}_{\tilde{p}_n}) := \llbracket (p_n, \text{lbl}_T) \rrbracket$. To produce that normalization algorithmically, proceed as follows. Consider a singular element $x \in \text{sing}(T_n)$ that is not a fiber endpoint, i.e. has adjacent regular elements $x_- \prec x \prec x_+$ in the fiber over $p_n(x)$. We say the element x is ‘redundant’ when the lower closure $T_n^{<x}$ contains no singular elements and $\text{lbl}_T(x_{\pm} \rightarrow x) = \text{id}$. Iteratively remove all redundant elements from T_n , by quotients that identify x with the adjacent elements x_{\pm} ; such quotients may create new redundant elements for removal, along the way. This process yields the stratified 1-truss bundle $\tilde{p}_n : \tilde{T}_n \rightarrow T_{n-1}$; the labeling lbl_T descends along the quotient $T_n \rightarrow \tilde{T}_n$ to provide the labeling $\text{lbl}_{\tilde{p}_n}$.⁴³

Equipped with that normalized bundle \tilde{p}_n , now construct a ‘projected’ stratified $(n-1)$ -truss $T_{<n}$, whose underlying truss is the $(n-1)$ -truncation $\underline{T}_{<n}$ of the underlying n -truss \underline{T} . The stratification $\text{lbl}_{T_{<n}}$ of the poset T_{n-1} will be the connected component splitting of a filtration (see Remark B.1.49), specified as follows. We will refer to the subposet of T_{n-1} , consisting of elements of depth less than or equal to i , as its ‘ i -skeleton’. Define the filtration $T_{n-1} \equiv X_{n-1} \supset X_{n-2} \supset \cdots \supset X_0$, inductively in decreasing i , by setting $X_i^{\circ} := X_i \setminus X_{i-1}$ to be the maximal open subposet of X_i , which is also open in the i -skeleton of T_{n-1} , on which the bundle \tilde{p}_n is constant on each connected component. (The construction of this projected stratification echos the one used for minimal coarsest refining meshes in the proof of Theorem 5.2.30.)⁴⁴

Suppose inductively that the algorithm we are in the midst of describing works, and produces a normal form stratified $(n-1)$ -truss $\tilde{\tilde{T}}_{<n} := \llbracket T_{<n} \rrbracket$. (In practice, this means begin by normalizing the stratified 1-truss bundle $p_{n-1} : T_{n-1} \rightarrow T_{n-2}$ as above to produce $\tilde{p}_{n-1} : \tilde{T}_{n-1} \rightarrow T_{n-2}$, and then read the remainder of the construction, and apply it at the $(n-1)$ -stage, and so forth iteratively down and then back up the tower to obtain $\tilde{\tilde{T}}_{<n}$.) By the definition of the stratified $(n-1)$ -truss $\tilde{\tilde{T}}_{<n}$ (as a normalization of an $(n-1)$ -truss stratified by the normal type of labeled 1-truss fibers), there is a unique stratified 1-truss bundle $\tilde{\tilde{p}}_n : \tilde{\tilde{T}}_n \rightarrow \tilde{\tilde{T}}_{n-1}$ whose pullback along $T_{n-1} \rightarrow \tilde{\tilde{T}}_{n-1}$ is the bundle $\tilde{p}_n : \tilde{T}_n \rightarrow T_{n-1}$. Augmenting $\tilde{\tilde{T}}_{<n}$ with the

⁴³Note that this procedure for normalization of a stratified 1-truss bundle works perfectly well more generally for a category-labeled 1-truss bundle.

⁴⁴Alternatively, at the expense of expanding context to category-labeled 1-truss bundles, we may construct the labeling $\text{lbl}_{T_{<n}}$ as the classifying functor for the labeled 1-truss bundle $(\tilde{p}_n, \text{lbl}_{\tilde{p}_n})$.

bundle \tilde{p}_n yields the normalized truss $\llbracket T \rrbracket$, as desired. (The procedure also applies in the case of stratified n -truss bundles.) \square

From the computability of normal forms of stratified trusses, we may now immediately derive that one can algorithmically determine the coarsest refining mesh of a tame stratification, and decide whether two tame stratifications are framed stratified homeomorphic.

PROOF OF COROLLARY 5.1.29. Let (Z, f) be a tame stratification, whose tameness is witnessed by a refining mesh M . Form the fundamental stratified truss $\mathbb{P}_\top(M, f)$ and compute its normal form $\llbracket \mathbb{P}_\top(M, f) \rrbracket$. The truss coarsening $\mathbb{P}_\top(M, f) \rightarrow \llbracket \mathbb{P}_\top(M, f) \rrbracket$ determines a mesh coarsening $M \rightarrow M'$, the target of which is the coarsest refining mesh of the tame stratification. \square

PROOF OF THEOREM 5.1.30. Given tame stratifications (Z, f) and (W, g) , determine their coarsest refining meshes M and N , respectively. Those tame stratifications are framed stratified homeomorphic if and only if the corresponding stratified trusses $\mathbb{P}_\top(M, f)$ and $\mathbb{P}_\top(N, g)$ are balanced isomorphic. Whether such a balanced isomorphism exists is certainly algorithmically decidable, and thus so is the given homeomorphism problem. \square

The thus established computational tractability of tame stratifications hinges on the existence of mutual *coarsenings* of mesh decompositions; we close by reiterating how contrary in character that property is from the classical Hauptvermutung mirage of mutual *refinements* of triangulations or cellular decompositions.

5.3.3.2. Tame singularities, tame cells, and their duality. As we have highlighted along the way, one of the distinguishing features of framed combinatorial topology is that it is self-contained under duality: every open truss has a dual closed truss and vice versa, and similarly every open mesh has a dual closed mesh and vice versa. As a consequence, most results immediately have a correlate dual. In particular, the confluence of stratified truss *coarsening*, given above in [Proposition 5.3.59](#), implies the dual statement that stratified truss *degeneracies* are confluent. We will discuss and illustrate that latter confluence shortly, but beforehand we take the opportunity to describe the elementary components of tame stratifications, namely tame cells and tame singularities, and their duality. With that duality in mind, we will be better equipped to appreciate degeneracy confluence.

Recall from [Definition 5.3.20](#) that a mesh cell is a stratified mesh block for which the dense stratum of the block is a stratum of the stratification; and a mesh singularity is a stratified mesh brace for which the cone stratum of the brace is a stratum of the stratification. The examples in [Figures 5.29](#) and [5.30](#) will call to mind these notions. Because we now know that a tame stratification has a canonical coarsest refining mesh, we may discard (without undue consequence), from the notions of mesh cells and mesh singularities,

the underlying mesh; all that is retained is the euclidean stratification. The resulting notions are that of tame cells and tame singularities, as follows.

DEFINITION 5.3.66 (Tame cells). An n -**tame m -cell** is an n -tame stratification (Z, f) , whose coarsest refining mesh M with the stratification f is an n -mesh m -cell (M, f) . \square

DEFINITION 5.3.67 (Tame singularities). An n -**tame m -singularity** is an n -tame stratification (Z, f) , whose coarsest refining mesh M with the stratification f is an n -mesh m -singularity (M, f) . \square

REMARK 5.3.68 (Tame cells and singularities via normalized trusses). From [Lemma 5.3.32](#) we know that coarsest refining meshes correspond to normalized stratified trusses, and altogether by [Theorem 5.1.23](#) that tame stratifications are classified by normalized stratified trusses. The notions of tame cell and tame singularity may therefore be rephrased more combinatorially as follows: a tame cell is a tame stratification whose classifying normalized stratified truss is a truss cell; similarly a tame singularity is a tame stratification whose classifying normalized stratified truss is a truss singularity. In practice, given a tame stratification whose tameness is witnessed by a refining mesh, one takes the stratified fundamental truss of the refining mesh, computes its normalization, and checks if the result is a truss cell or truss singularity. \square

EXAMPLE 5.3.69 (Tame cells and singularities). In [Figure 5.37](#), we depict a collection of tame cells and tame singularities, and a duality relating them. (The duality will be described in the subsequent construction.) On the left are three 2-tame singularities and their dual 2-tame cells. (Of course these are the singularities and cells whose tameness is witnessed by the (coarsest) refining meshes shown in [Figures 5.29](#) and [5.30](#).) On the right are three 3-tame singularities and their dual 3-tame cells. Note that excepting the top right tame singularity, the other five tame singularities are classified by the five truss singularities in [Figure 5.27](#). \square

The duality of cells and singularities illustrated in the preceding example is a special case of a general procedure of dualizing tame stratifications, which is formalized as follows.

CONSTRUCTION 5.3.70 (Dual stratifications). Let (Z, f) be an n -tame stratification. Construct its classifying normalized stratified truss $T = (\underline{T}, \text{lbl}_T)$, as provided by [Theorem 5.1.23](#). (Practically, from any refining mesh of the tame stratification, take the stratified fundamental truss and normalize it by [Observation 5.3.64](#) or [Remark 5.3.65](#).) Define the **dual stratified truss** $T^\dagger \equiv ((T^\dagger), \text{lbl}_{T^\dagger})$ to have underlying truss $(\underline{T}^\dagger) := (\underline{T})^\dagger$ and labeling $\text{lbl}_{T^\dagger} := \text{lbl}_T^{\text{op}} : T_n^{\text{op}} \rightarrow \mathbb{N}(T)^{\text{op}}$. Take the stratified mesh realization $(M^\dagger, f^\dagger) := \|\underline{T}^\dagger\|_M$ of that dual stratified truss. Finally define the **dual tame stratification** $(Z, f)^\dagger := (Z^\dagger, f^\dagger)$ to be the tame stratification of the space $Z^\dagger := (M^\dagger)_n \subset \mathbb{R}^n$ with the stratification f^\dagger . \square

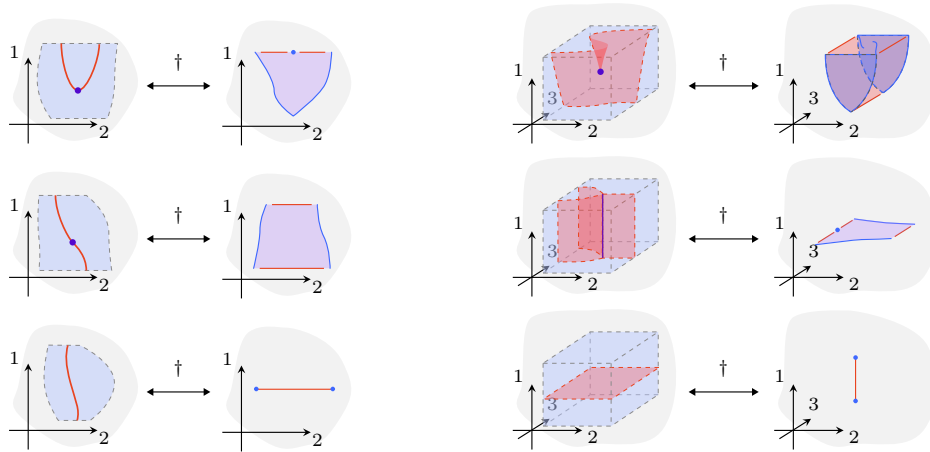

FIGURE 5.37. Tame singularities and their dual tame cells.

EXAMPLE 5.3.71 (Dual stratifications). In Figure 5.38, we depict two pairs of dual tame stratifications. The first tame stratification is familiar from the last example in Figure 5.2, and the third tame stratification witnesses the tameness of the middle embedding in Figure 5.3. —

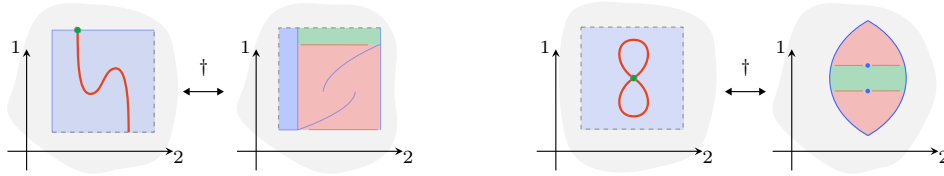

FIGURE 5.38. Duality of tame stratifications.

REMARK 5.3.72 (Dual stratified maps). The duality of stratifications can also be applied to maps of stratifications. Given a map $F : T \rightarrow S$ of stratified trusses, one has the dual map $F^\dagger := F^{\text{op}} : T^\dagger \rightarrow S^\dagger$ of the respective dual stratified trusses. Correspondingly, we say that maps of tame stratifications $(Z, f) \rightarrow (Y, g)$ and $(Z^\dagger, f^\dagger) \rightarrow (Y^\dagger, g^\dagger)$ ‘are dual’ when their stratified fundamental truss maps are dual. —

We may now return to dualizing the confluence of truss coarsening to a confluence of truss degeneracies. Recall from Terminologies 2.3.63 and 2.3.65 that a map of (unstratified) n -trusses is a degeneracy when, on every 1-truss fiber map in the whole tower, it is surjective, endpoint-type-preserving, and singular.

TERMINOLOGY 5.3.73 (Degeneracies of stratified trusses). A map $F : T \rightarrow S$ of stratified trusses is a ‘truss degeneracy’ if the underlying truss map \underline{F} is a degeneracy of n -trusses, and the label map lbl_F is the identity. —

Proposition 5.3.59 established that any chain of non-identity truss coarsenings eventually ends in the same normalized truss. The dual statement follows immediately.

COROLLARY 5.3.74 (Stratified truss degeneracy is confluent). *Let T be a stratified n -truss. Every maximal chain of non-identity truss degeneracies, beginning with T , ends in the same stratified n -truss. Furthermore there is a unique truss degeneracy from the given stratified truss T to that maximally degenerated stratified truss.*

We may refer to that maximally degenerated stratified truss as being the ‘degeneracy normal form’ of the initial stratified truss.

Despite requiring no further work, this result has a rather different character from the confluence of truss coarsening: a truss coarsening fundamentally preserves the topology of the associated stratification (here associated means via stratified mesh realization), whereas a truss degeneracy definitely alters that topology. Of course, the topological degenerations that can occur in a truss degeneracy are constrained by the preservation of the overall architecture of the associated framed stratification; still, it is notable that there is a unique way to maximally collapse regions in a tame stratification without intrinsically altering the character of its framed stratified structure.

Recall from Terminology 5.3.18 that a mesh coarsening (of stratified meshes) is a map of stratified meshes that is a coarsening of underlying meshes and is an identity of stratifications. Similarly, a ‘mesh degeneracy’ (of stratified meshes) is a map of stratified meshes that is a degeneracy of underlying meshes and is an identity of stratifications. (See Terminologies 4.1.20 and 4.1.91.) Note that the stratified fundamental truss map of a mesh degeneracy is a truss degeneracy.

TERMINOLOGY 5.3.75 (Degeneracies of tame stratifications). Let (Z, f) and (Z', f') be tame stratifications with coarsest refining meshes M and M' respectively. A framed map of tame stratifications $(Z, f) \rightarrow (Z', f')$ is a ‘degeneracy’ if it induces a map of stratified meshes $M \rightarrow M'$ that is a mesh degeneracy. —

EXAMPLE 5.3.76 (Degeneracies of tame stratifications). In Figure 5.39, we depict three maps of tame stratifications that are degeneracies. In fact, each of these degeneracies is maximal, in the sense that no further degeneration is possible, or equivalently that the stratified fundamental truss of the target is in degeneracy normal form. —

5.3.3.3. Coarsest cell structures and framed homeomorphism. A space that admits a regular cell complex structure has, of course, numerous distinct such cell structures, among which there is in no reasonable sense a canonical one. Any cell structure may be subdivided indefinitely, so there is certainly no finest or ‘maximal’ cell structure; hypothetically one might ask for a coarsest or ‘minimal’ cell structure, but that simply does not exist.

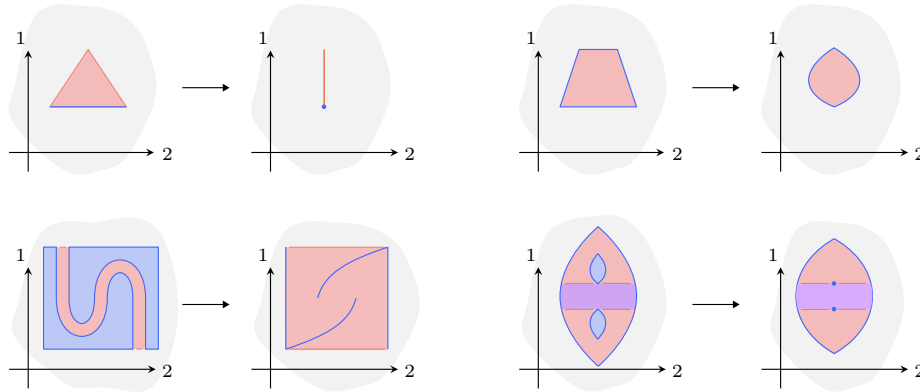

FIGURE 5.39. Degeneracies of tame stratifications.

Adding a framing does not by itself fix matters: given a framed regular cell complex, there is no coarsest cell structure in its framed homeomorphism class. However, insisting that there is a framed realization does the trick: we will presently see that given a framed regular cell complex admitting a framed realization, there is a canonical coarsest cell structure in its framed homeomorphism class.

Recall from Terminology 1.3.73, Definition 1.3.74, and Terminology 1.3.75 that we refer to n -framed regular cell complexes as n -directed graphs, and to n -framed regular cell complexes admitting a framed realization as n -directed acyclic graphs, or n -DAGs for short. Recall further from Construction 1.3.4 and Proposition 1.3.15 that, given a regular cell complex X , the stratified realization $\|X\|$ is the stratification of the geometric realization $|X|$ by open cells.

TERMINOLOGY 5.3.77 (Framed homeomorphisms of n -DAGs). A ‘framed homeomorphism’ $F : X \rightarrow Y$ between n -DAGs is a homeomorphism $F : |X| \rightarrow |Y|$, such that for any framed realization $i : |Y| \rightarrow \mathbb{R}^n$, the composite $i \circ F : |X| \rightarrow \mathbb{R}^n$ is a framed realization. —

This notion of framed homeomorphism signals that n -directedness is a structure that does not really depend on the cell complex structure of the n -graph, but exists intrinsically on the topological space of that complex.

TERMINOLOGY 5.3.78 (Framed coarsenings of n -DAGs). A framed homeomorphism $F : X \rightarrow Y$ of n -DAGs is a ‘framed coarsening’ if the stratified realization $F : \|X\| \rightarrow \|Y\|$ is a stratified coarsening. —

REMARK 5.3.79 (Framed homeomorphism of n -directed graphs). The above phrasing of the notion of framed homeomorphism is expedient for its use of acyclicity, but one need not in fact restrict attention to the acyclic case. A ‘framed homeomorphism’ of n -directed graphs is, for instance, a

homeomorphism of geometric realizations that is (in a suitably specified sense) a framed map on each cell.⁴⁵ —

TERMINOLOGY 5.3.80 (*n*-Directed spaces). An ‘*n*-directed graph structure’ on a space Z is an *n*-directed graph X together with a homeomorphism $|X| \cong Z$. An ‘*n*-directed space’ is a space with an *n*-directed graph structure. Similarly an ‘*n*-directed acyclic space’ is a space with an ‘*n*-directed acyclic graph structure’ i.e. an *n*-DAG and a homeomorphism to the space. —

TERMINOLOGY 5.3.81 (Compatible *n*-directed structures). The *n*-directed (acyclic) graph structures $F : |X| \cong Z$ and $G : |Y| \cong Z$ are ‘compatible’ if the composite $G^{-1} \circ F$ is a framed homeomorphism.

Given an *n*-directed (acyclic) graph X , we say that an *n*-directed (acyclic) graph structure $G : |Y| \cong |X|$ is ‘compatible’ with X , meaning that G is compatible with the identity structure $\text{Id} : |X| \equiv |X|$. —

We are now equipped to state the advertized existence of coarsest cell structures. The proof, for which we merely provide ingredients, reprises the use of join stratifications from the construction of coarsest meshes in Section 5.2.2 and the use of section and spacer cells (see Definition 3.3.1) from the comparison of framed and proframed complexes.

THEOREM 5.3.82 (Coarsest cell structures of *n*-directed acyclic graphs). *Given an n-DAG X, there is a unique compatible n-DAG structure X_{\min} on the space $|X|$, that admits no framed coarsening. Furthermore, every n-DAG structure compatible with the n-DAG X has a unique framed coarsening to X_{\min} .*

PROOF INGREDIENTS. Let $F : |X| \cong Z$ and $G : |Y| \cong Z$ be compatible *n*-DAG structures. For convenience, fix a map $i : Z \rightarrow \mathbb{R}^n$ such that $i \circ F$ and $i \circ G$ are framed realizations of X and Y , respectively. Denote by $f := F \parallel X \parallel$ and $g := G \parallel Y \parallel$ the induced cell stratifications on the underlying space Z . Now endeavor to show that the join $f \vee g$ is a regular cell complex, with framing and framed realization inherited from the map i . (That much suffices: from an *n*-DAG X , framed coarsen it until it can be framed coarsened no further, and call the result X_{\min} ; if there were a compatible *n*-DAG structure Y that does not coarsen to X_{\min} , then X_{\min} coarsens to the join of the structures X_{\min} and Y , a contradiction.)

As a preliminary matter, consider the ‘*n*-framed boundary complex’ $\partial_n X$, defined as follows. A cell $d \in X$ belongs to the boundary $\partial_n X$ when (1) it projects (by $\pi_n \circ i \circ F$) homeomorphically into \mathbb{R}^{n-1} , and (2) there is at most one cell $c \in X$ with $d \subset \partial c$ and $\pi_n \circ i \circ F(d) = \pi_n \circ i \circ F(c)$. Observe that the boundary complexes $\partial_n X$ and $\partial_n Y$ have identical images (call it $\partial_n Z$)

⁴⁵One way to specify that condition is as follows. The cell-to-mesh realization (see Terminology 4.2.7) of each framed cell is a mesh block, with its framed realization in euclidean space. For *n*-directed graphs X and Y , the homeomorphism $F : |X| \rightarrow |Y|$ is framed on the cell $x \in X$ if for each cell $y \in Y$, the restriction $F|_{x \cap F^{-1}(y)}$ is framed, via the cell-to-mesh realizations, in the sense of Definition 4.1.86.

in the underlying space Z , and $\pi_n \circ i \circ F$ and $\pi_n \circ i \circ G$ are $(n - 1)$ -framed realizations of those complexes. In particular then the boundary complexes $\partial_n X$ and $\partial_n Y$ provide compatible $(n - 1)$ -DAG structures. Let $\partial_n f$ and $\partial_n g$ denote the induced cell stratifications of the space $\partial_n Z$.

By induction, we have that the join $\partial_n f \vee \partial_n g$ is a regular cell complex, with framing and framed realization inherited from the map $\pi_n \circ i$. Now distinguish lower and upper boundary subcomplexes $(\partial_n f \vee \partial_n g)^\pm$ of the boundary join, and finally establish that the join $f \vee g$ is a suitably framed regular cell complex by the method of *section-spacer cell induction*, based at the lower boundary complex. \square

Recall that a tame embedding is by definition a constructible substratification of an open stratification admitting a mesh refinement. Further as we have seen, there is a minimal coarsest such refining mesh of an embedding. Suppose the embedding is compact and, for simplicity, trivially stratified; in that case, the minimal coarsest refining mesh (or indeed any refining mesh) induces an n -framed cell complex i.e. n -directed graph structure on the embedded space, as follows: take the fundamental truss of the refining mesh, cubically compactify it, take the mesh-to-cell gradient to produce a framed cell complex, and finally restrict to the subcomplex corresponding to the embedded image.

TERMINOLOGY 5.3.83 (Mesh cell structure). The ‘mesh cell structure’ of a tamely embedded compact space is the (acyclic) framed cell complex structure induced, via the above procedure, by the minimal coarsest refining mesh of the embedding. —

The mesh cell structure of a tamely embedded space is parsimonious, but it is by no means minimal as a framed cell structure, for it retains cellular subdivisions corresponding to a (now forgotten) global mesh structure. As a particular application of [Theorem 5.3.82](#), we can further and often drastically simplify the mesh cell structure to the coarsest cell structure of the n -directed acyclic graph itself.

EXAMPLE 5.3.84 (Coarsest cell structures of tame embeddings). In [Figure 5.40](#), we depict a tame embedding of the circle in \mathbb{R}^2 , along with (on the far right) its mesh cell structure, and a further framed coarsening to (on the center right) the coarsest cell structure of that mesh cell structure DAG. (As it happens in this case it does not matter whether this is considered as a 1-DAG or a 2-DAG.) That coarsest cell structure is the minimal, canonical framed cell structure on the directed space defined by the tame embedding. —

As the existence of coarsest refining meshes gave us an algorithmic handle on framed stratified homeomorphism of tame stratifications (see [Theorem 5.1.30](#)), the existence of coarsest cell structures provides similar purchase on framed homeomorphism of n -directed acyclic graphs, as follows.

PROOF OF [THEOREM 5.1.31](#). Given n -DAGs X and Y , determine their coarsest cell structures X_{\min} and Y_{\min} . (That determination may be achieved

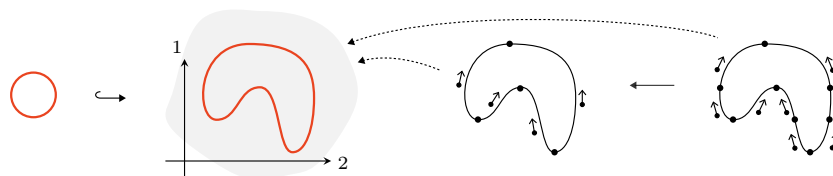

FIGURE 5.40. Coarsest cell structure of a tamely embedded circle.

for instance by greedily taking any maximal chain of framed coarsenings whose underlying homeomorphism is the identity.) Then determine (by exhaustion if nothing else) whether X_{\min} and Y_{\min} are isomorphic as n -DAGs. Applying [Theorem 5.3.82](#) (see also [Terminology 5.3.81](#)), note that those coarsest n -DAGs are isomorphic if and only if the original n -DAGs are framed homeomorphic. \square

EXAMPLE 5.3.85 (Deciding framed homeomorphism of 1-DAGs). In [Figure 5.41](#), we depict the procedure for deciding framed homeomorphism of n -DAGs, in the 1-dimensional case for simplicity. On the top left and top right are two given 1-DAGs, with the direction of every cell indicated concisely by the red arrows. The dashed gray arrows are the framed coarsenings to the respective coarsest cell structures, which are directed isomorphic as shown. \square

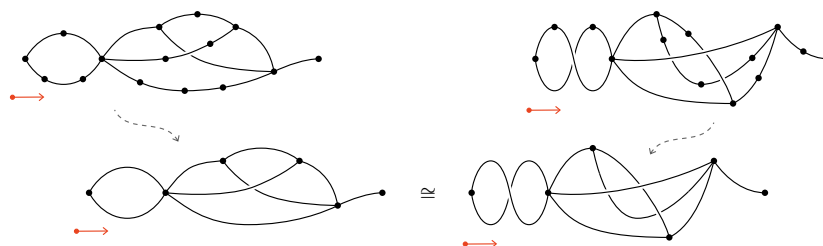

FIGURE 5.41. Decidability of framed homeomorphism for 1-DAGs.

5.4. Coda on manifold diagrams and tame tangles

Tame stratifications admit, by characterizing definition, refinement by a mesh. Each stratum of such a refining mesh has a specific declination with respect to the ambient framing, but a stratum of the tame stratification itself may wander within that framing and so does not explicitly display the structure of its framed combinatorialization. A framed conical tame stratification is a tame stratification each of whose strata, by contrast, does have a definite, uniform framing type (a requirement made precise by insisting that the local neighborhoods are framed stratified homeomorphic to tame singularities). The strata of a framed conical tame stratification, though frame well-typed, may not be transversally positioned with respect to the frame foliations of euclidean space. A *manifold diagram* is a framed conical tame stratification all of whose strata are indeed suitably transversal (a condition made precise by insisting that the standard projection from each stratum to the equidimensional euclidean space is a local homeomorphism). An example of a manifold diagram is illustrated on the left in [Figure 5.42](#); this is a stratification of an open cube with two point strata (a cusp and a saddle), three line strata (folds), two surface strata (one of which, note, does not project homeomorphically onto its image in the plane), and two bulk strata. (The thin horizontal guidelines are not strata, but merely convey the arrangement of the surface in the euclidean space.)

Recall a tame embedding is an embedding of a stratified space into euclidean space, whose stratified image is a constructible substratification of an open tame stratification. A *tame tangle* is a tame embedding of an unstratified manifold whose tame constructible superstratification admits a refinement by a manifold diagram. Informally then, a tame tangle is a manifold embedded in euclidean space, sufficiently generically that it can be refined by a stratification each of whose strata is transversal to the ambient framing. An example of a tame tangle is illustrated by the right embedding map in [Figure 5.42](#); its source depicts an unstratified 2-disc and its target depicts the unstratified image of the embedding, while the left map indicates the refinement by the manifold diagram. (Again, the thin blue guidelines in the disc are not strata, but serve to indicate the embedding.) When the refining manifold diagram of a tame tangle is as coarse as possible, the refined strata are called the critical strata of the tangle, as they encode the decomposition by critical behavior under the hierarchy of all the standard projections simultaneously. In the example, the thin green lines and points indicate the critical stratification of the source 2-disc.

FIGURE 5.42. A manifold diagram and a tame tangle.

OUTLINE. In [Section 5.4.1](#), we describe framed conical tame stratifications, as tame stratifications having tame singularities as local neighborhoods, and define manifold diagrams, as tame stratifications having transversal tame singularities as local neighborhoods. Then in [Section 5.4.2](#), we introduce tame

tangles as tame embeddings of unstratified manifolds that admit a manifold diagram refinement, describe tangle singularities i.e. local neighborhoods in tame tangles, and conjecture that the combinatorial structure of a tame tangle entirely encodes its smooth structure.

5.4.1. Manifold diagrams.

SYNOPSIS. We motivate, introduce, and illustrate framed conical tame stratifications as those tame stratifications whose local neighborhoods are tame singularities. We then describe transversal tame singularities as those whose central strata are transverse to the fibers of the standard projections, and define manifold diagrams as tame stratifications whose local neighborhoods are transversal tame singularities.

5.4.1.1. Framed conicality. For a space, one of the simplest and strongest uniformity constraints one may impose is that the local neighborhoods are the same throughout the space. Typically one asks those local model neighborhoods to be euclidean balls. The space has a characteristic type, depending on which local model is selected, and the allowable types correspond of course to the dimension of the space.

For a stratified space, the most one may sensibly demand is that the local stratified neighborhoods are the same throughout each stratum separately. Again typically, one asks those local model stratified neighborhoods to be products of a euclidean ball and a stratified cone of a reasonable stratification of a sphere.⁴⁶ (A stratified space based on such local models is in particular conical, see [Definition B.3.2.](#)) Each stratum has a characteristic type, depending on which local model is in force for that stratum, and the allowable types correspond to the dimension of the stratum together with the stratification of its spherical link.

For a framed stratified space, we provide an analogous condition, namely that the local framed stratified neighborhoods are the same throughout each stratum. We are responsible for specifying a class of allowable local model framed stratified neighborhoods. One may consider the local model framed stratified neighborhoods to be (in a sense sketched in [Remark 5.4.3](#)) framed products of a euclidean ball and a framed stratified cone of a reasonable framed stratification of a sphere.⁴⁷ Happily, we have already defined a class of potential local neighborhoods—namely the tame singularities—which, though not identical to the aforementioned class of local neighborhoods (a tame singularity need not be a framed product of a ball and a cone on

⁴⁶Here, ‘reasonable’ may be defined inductively, i.e. a reasonable stratification of a sphere is one with local models that are products of balls and stratified cones on reasonable lower-dimensional spheres. In fact, that class of model neighborhoods may be alternatively described as conical stratifications of balls by submanifolds. More generally, the resulting class of reasonable stratifications is the conical stratifications of manifolds by submanifolds.

⁴⁷Here again, ‘reasonable’ may be defined inductively, i.e. a reasonable framed stratification of a sphere is one with local models that are framed products of balls and framed stratified cones of reasonable lower-dimensional spheres—see [Remark 5.4.4](#).

a *reasonable* sphere), determines exactly the same global class of framed stratifications, when prescribed at all points. We have then, finally, the following definition.

DEFINITION 5.4.1 (Framed conical tame stratifications). A **framed conical tame stratification** is a tame stratification all of whose points have neighborhoods that are framed stratified homeomorphic to tame singularities. —

The story of framed conicality extends to tame embeddings by considering open neighborhoods of the image, as follows.

DEFINITION 5.4.2 (Framed conical tame embeddings). A **framed conical tame embedding** is a tame embedding all of whose image points have (tamely stratified) tame open neighborhoods that are framed stratified homeomorphic to tame singularities. —

REMARK 5.4.3 (Tame singularities as framed products). In the preceding definitions, we have used tame singularities as local models for framed conical tame stratifications and embeddings. Recall that the local models for conical stratifications are products of a ‘tangential’ euclidean ball and a ‘normal’ stratified cone. Tame singularities are framed products in the sense that the coarsest refining mesh of a singularity has a set of trivial open 1-mesh fibers forming an unstratified open ball (tangent to the cone stratum) interleaved with a set of non-trivial open 1-mesh fibers forming a stratified cone (normal to the cone stratum). The order of interleaving controls which framed directions assemble to each of the tangential and normal factors. —

REMARK 5.4.4 (Inductive framed conicality). A priori there would appear to be two distinct conditions contending for the name ‘framed conicality’: either having neighborhoods that are tame singularities, or having neighborhoods that are (inductively) framed conical tame singularities. (That latter condition is not circular because in a cone stratification, away from the cone point, all strata are positive-dimensional.) However, in fact, the first condition implies the second, and so both specify the same desired class of stratifications.⁴⁸ —

EXAMPLE 5.4.5 (Framed conical tame stratifications). In Figure 5.43, we depict two framed conical tame stratifications (on the left), and respectively two coarsenings of those stratifications that are not framed conical (on the right). The dotted circles indicate the points that do not have the required framed conical neighborhoods. Note that these are the points where a stratum fundamentally changes its relationship to the standard framing projections. —

⁴⁸Unframed conicality is sometimes defined as having neighborhoods that are products of a euclidean space and a cone on a stratified space, and sometimes defined as having neighborhoods that are products of a euclidean space and a cone on a conically stratified space. Comparing those notions is a famous morass of both classical and modern stratified topology.

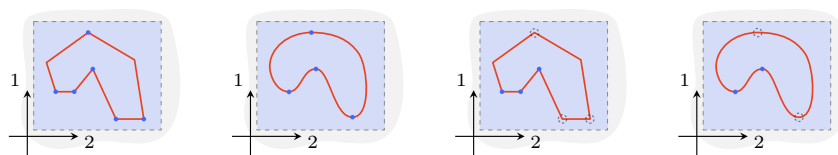

FIGURE 5.43. Framed conical and not framed conical stratifications.

EXAMPLE 5.4.6 (Framed conical tame embeddings). In Figure 5.44, we depict two framed conical tame embeddings (on the left), and respectively two coarsenings of those embedding that are not framed conical (on the right). The left two embeddings each have two point strata, two line strata, and two surface strata, while the right two embeddings each have only a single stratum. Note that in the left-most embedding, the diamond region is collapsed to a line by the standard projection whose kernel is the 3-frame vector. —

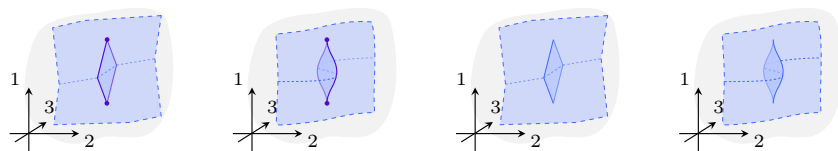

FIGURE 5.44. Framed conical and not framed conical embeddings.

REMARK 5.4.7 (Framed conical stratified trusses). As is by now expected, framed conical stratifications have a corresponding combinatorial formulation. A ‘framed conical stratified truss’ is a stratified truss (T, lbl_T) such that, for each element $x \in T$, the stratified subtruss $(T^{\geq x}, (\text{lbl}_T)|_{T^{\geq x}})$ (obtained by restricting to the upper closure of the element) normalizes to a truss singularity. From the correspondence of tame stratifications and normalized stratified trusses, one infers that framed conical tame stratifications are classified by framed conical normalized stratified trusses. —

5.4.1.2. Transversality. Each stratum in a framed conical tame stratification or embedding has a single well-defined relationship to the ambient framing of euclidean space. However, that relationship need not be generic, in the sense that a small perturbation of the placement of a stratum can change its interaction with the ambient framing. The spirit of this notion of genericity may be illustrated as follows.

EXAMPLE 5.4.8 (Genericity of framings). In Figure 5.45, we depict six tame linear embeddings of the open interval into \mathbb{R}^2 . Whenever we refer to the framing of a euclidean space (and thus genericity with respect to that framing), we mean of course the structure encoded in its tower of

standard projections (or equivalently in its foliations by affine kernels of those projections). In this case the tower is just the single standard projection $\pi_2 : \mathbb{R}^2 \rightarrow \mathbb{R}^1$. Post-compose the embeddings with that standard projection: for the green embeddings, the result is a local homeomorphism into \mathbb{R}^1 , whereas for the blue embedding the result collapses the interval to a point. On that basis, we distinguish the green embeddings as generic, and the blue embedding as not generic.⁴⁹ Of course, it is also the case that for the green (but not blue) embeddings, a small linear perturbation of the embedding preserves the local homeomorphicity of the projection. \square

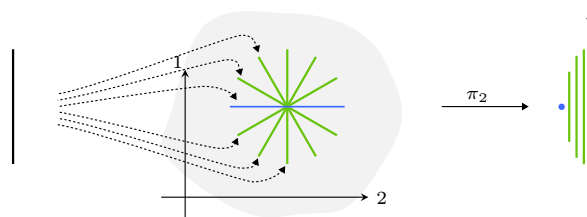

FIGURE 5.45. Genericity of framings on the embedded interval.

As the word ‘generic’ is itself a bit unspecific (if accurate in this case), we will refer instead to a stratum being ‘transversal’. The condition can also be rephrased with transversality as the primary technical requirement. For instance, in the previous example, the green embeddings are transversal to the fibers of the standard projection, while the blue embedding is not. More generally, we have the following notion of transversality for a euclidean embedding of a manifold of any dimension.

TERMINOLOGY 5.4.9 (Transversal embedding). We say a tame embedding of an m -manifold $\iota : W^m \hookrightarrow \mathbb{R}^n$ is ‘transversal’ if post-composition with the projection $\pi_{\leq m} : \mathbb{R}^n = \mathbb{R}^m \times \mathbb{R}^{n-m} \rightarrow \mathbb{R}^m$ yields a local homeomorphism $W \rightarrow \mathbb{R}^m$. \square

That condition delineates a pertinent class of tame singularities, as follows.

DEFINITION 5.4.10 (Transversal tame singularities). A tame m -singularity is **transversal** if its cone m -stratum is transversal. \square

EXAMPLE 5.4.11 (Transversal singularities). Any tame 0-singularity, i.e. a tame singularity whose cone stratum is 0-dimensional, is necessarily transversal. In particular this applies to the first two 2-dimensional singularities and the first 3-dimensional singularity in Figure 5.37. The last 2-dimensional singularity and the second 3-dimensional singularity are also transversal as the

⁴⁹Notice that, reconsidering the picture as referring to framed realizations of 1-simplices, the green embeddings correspond to realizations of the framed simplex with frame label 1, while the blue embedding corresponds to a realization of the framed simplex with (the more specialized) frame label 2. See Definition 1.1.44 and the subsequent example.

central line strata certainly project locally homeomorphically to the 1-frame axis. Only the last 3-dimensional singularity fails to be transversal. Since we primarily care about the transversal case, and any given stratification may be perturbed into a transversal state, most of our illustrations have been of that kind. —|

REMARK 5.4.12 (Transversality via the coarsest mesh). Since the condition of transversality of a tame singularity is formulated in terms of the projection of the cone stratum of the underlying mesh brace, transversality has another convenient formulation as follows. A tame m -singularity is transversal exactly when, in its coarsest refining mesh $M = (p_n, p_{n-1}, \dots, p_1)$, the last m bundles p_m, \dots, p_1 have trivial open 1-mesh fiber. Of course, one may translate this condition across the mesh-to-truss equivalence to obtain an entirely combinatorial characterization of transversality. —|

We may now restrict the class of framed conical tame stratifications by insisting that the local neighborhoods are not only tame singularities but transversal tame singularities, as follows.

DEFINITION 5.4.13 (Manifold diagrams). A **manifold diagram** is a tame stratification all of whose points have neighborhoods that are framed stratified homomorphic to transversal tame singularities. —|

More specifically, such an n -tame stratification is called a ‘manifold n -diagram’.

EXAMPLE 5.4.14 (Failures of transversality). In Figure 5.43, consider again the first two framed conical stratifications. The first stratification is not a manifold diagram, since the bottom two line strata are not transversal, but the second stratification is a manifold diagram. Similarly, consider augmenting the first two tame embeddings of Figure 5.44 with two ambient bulk strata, to obtain framed conical stratifications. The first such stratification is not a manifold diagram, since the diamond stratum is not transversal, but the second stratification is a manifold diagram. —|

We could use the term ‘manifold diagram embedding’ for a tame embedding whose image is a constructible substratification of an open manifold diagram. In that sense the second embedding of Figure 5.44 is a manifold diagram embedding.

EXAMPLE 5.4.15 (Manifold diagrams). In Figure 5.46, we depict two stratifications with strata extending to the boundary. The left stratification is a manifold 2-diagram, whereas the right stratification is not, being merely a framed conical 2-tame stratification. —|

◇ See paper list for fig switch in next eg. (No tangles)

REMARK 5.4.16 (Combinatorial manifold diagrams). We noted in Remark 5.4.7 that framed conical tame stratifications admit a combinatorial encoding as framed conical stratified trusses, and mentioned in Remark 5.4.12 the combinatorial version of the transversality condition. Together these

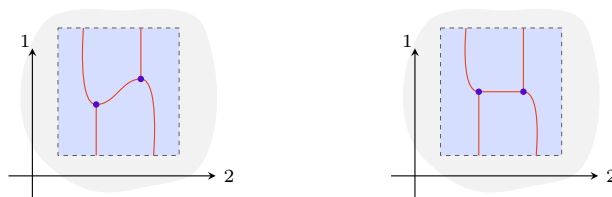

FIGURE 5.46. A manifold diagram and not a manifold diagram.

provide a full and faithful combinatorial classification of manifold diagrams (up to framed stratified homomorphism) as follows: a **combinatorial manifold n -diagram** is a stratified n -truss (T, lbl_T) for which, for every element $x \in T_n$, the neighborhood $T^{\geq x}$ normalizes to an n -truss m -singularity whose last m bundles have trivial open 1-truss fiber. \square

A stringent notion of equivalence of manifold diagrams is, naturally, framed stratified homomorphism. However, more flexibly, two manifold diagrams may be related by a geometric deformation that does not preserve the global framed relationships among the strata, but nevertheless can be achieved without any local piece undergoing an essential framing change (which would necessitate a point singularity, to preserve framed conicality). That sort of deformation is concisely encoded by the following notion.

DEFINITION 5.4.17 (Manifold diagram isotopies). A **manifold n -diagram isotopy** is a manifold $(n + 1)$ -diagram that does not contain 0-singularities. \square

In particular, given a manifold n -diagram isotopy e , with coarsest refining mesh M , consider the 1-mesh truncation M_1 and select points $s \in M_1 \subset \mathbb{R}^1$ and $t \in M_1 \subset \mathbb{R}^1$ which are respectively in the lowest and highest strata. The fibers of the isotopy over those points, i.e. $d_s := e \cap \pi_{>1}^{-1}(s) \subset \mathbb{R}^{n+1}$ and $d_t := e \cap \pi_{>1}^{-1}(t) \subset \mathbb{R}^{n+1}$, are manifold n -diagrams, and we say that the manifold diagram isotopy is ‘between’ them. More generally, we may consider deformations with more than one parameter: a ‘manifold n -diagram k -isotopy’ is a manifold $(n + k)$ -diagram that does not contain any l -singularities for $l < k$.

EXAMPLE 5.4.18 (Manifold diagram isotopies). A simple manifold diagram isotopy is the braid, as obtained from Figure 5.33 by adding a single open bulk stratum. This isotopy is between two manifold 2-diagrams, the bottom and top slices in the given depiction, each consisting of two points embedded in the plane. Within such a slice, informally interpreting the 2-frame direction as temporal, the isotopy switches the order in which the points occur.

In Figure 5.47, we depict a manifold 3-diagram isotopy, as a series of three slices, each of which is a manifold 3-diagram. Each slice has three point strata, six line strata, and a single implicit bulk stratum. As in any manifold diagram

isotopy, there is no moment and point where, locally, anything substantive happens, but nevertheless, the global framed arrangement of the strata is altered by the isotopy. (If one merges the point and line strata, the resulting manifold 2-diagram 2-isotopy is the Reidemeister move shown previously in Figure I.7. Notice that the swallowtail stratification in that same figure does not represent an isotopy, because any manifold diagram refinement of it will necessarily contain a 0-singularity.) We will have to leave for another time illustrating and enumerating higher-dimensional isotopies. \square

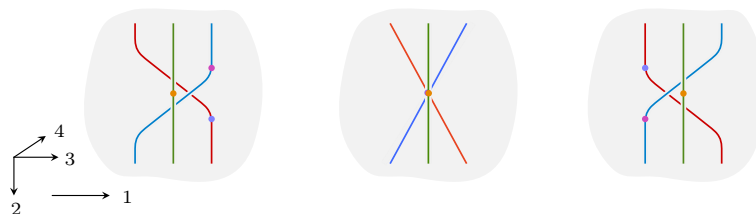

FIGURE 5.47. A manifold 3-diagram isotopy.

REMARK 5.4.19 (String diagrams and surface diagrams). String diagrams, i.e. stratifications of 2-dimensional euclidean space by transversal lines and their intersection points, were of course the first stratified topological formalization of a theory of diagrammatic composition [Hot65, Pen71, JS91]. Manifold 2-diagrams recover more or less precisely the classical notion of string diagrams (and of course provide a combinatorialization of it). Surface diagrams, i.e. stratifications of 3-dimensional euclidean space by transversal surfaces and their transversal intersection lines and points, were developed rather later [Hum12], following extensive efforts (see [Tri99] for some history and context). Manifold 3-diagrams recover to reasonable approximation that notion of surface diagrams (and again provide an attendant combinatorialization). No general theory of suitably transversal stratifications of 4-dimensional euclidean space has previously been formulated, but there have been concentrated efforts in the case of codimension-2 non-singular surface diagrams [CKS96, CS98]. Manifold 4-diagrams specialize (by disallowing 3-dimensional strata and insisting that the 2-, 1-, and 0-dimensional strata form a non-singular embedded surface) to provide a concise definition and model of that notion of progressive embedded surfaces, along with a convenient corresponding combinatorialization thereof. More generally, manifold 4-diagrams complete the story in 4-dimensions by allowing 3-dimensional strata and surface intersections and singularities. Manifold n -diagrams resolve finally the search for a theory of higher string diagrams in general, and come at the outset with a complete combinatorial classification of such diagrams. \square

REMARK 5.4.20 (Cellular diagrams). As we have emphasized, a convenient feature of our formulation of tame stratifications is that it admits a self-duality (see Construction 5.3.70). We may therefore in particular forcibly

dualize the notion of manifold diagram: a ‘cellular diagram’ is a tame stratification whose dual tame stratification is a manifold diagram. (Of course one may formulate cellular diagrams directly in terms of transversal tame cells, but we do not undertake that here.) As manifold diagrams generalize existing low-dimensional versions of string diagrams to all dimensions, so cellular diagrams generalize existing low-dimensional versions of ‘pasting diagrams’ to all dimensions; as such, cellular diagrams record compositional configurations of morphisms in higher categories, but they also encode all coherence modifications among higher-categorical compositions, in the form of cellular duals of manifold diagram isotopies (contrast [Ste93, For22] and compare [Had24]). —

5.4.2. Tame tangles.

SYNOPSIS. We define tame tangles as tame embeddings of unstratified manifolds that can be refined by manifold diagrams. We then introduce tangle singularities, i.e. the local neighborhoods in tame tangles, and tangle isotopies, i.e. the deformations of tame tangles, and investigate the behavior of tangle singularities under perturbation. We conclude by conjecturing that the combinatorial structure of a tame tangle determines its smooth structure, and that any smooth embedding is isotopic to a tame tangle.

5.4.2.1. The definition. Recall that a ‘tangle’ typically refers to a manifold embedded in euclidean space. A ‘tame tangle’ will be a tamely embedded manifold admitting, in a suitable sense, a refinement by transversal strata.

To specify that notion of refinement, it is convenient to consider tame stratified neighborhoods of the embedding. By definition, any tame embedding $\iota : (W, g) \hookrightarrow \mathbb{R}^n$ admits an ‘extension’ to an open tame stratification (Z, f) , in the sense that the image $\iota(W, g)$ is a constructible substratification of (Z, f) . Any refinement of the tame stratification (Z, f) induces a refinement of the embedded substratification $\iota(W, g)$ simply by restriction. For brevity, we refer to the combination of extending from the embedding to the stratified neighborhood and then refining that neighborhood, together simply as ‘refinement’, as follows.

TERMINOLOGY 5.4.21 (Refining embeddings by tame stratifications). Given an n -tame embedding $\iota : (W, g) \hookrightarrow \mathbb{R}^n$, we say that an open tame stratification (Z, f) ‘refines the embedding’ ι if each stratum of the image $\iota(W, g)$ is a union of strata of (Z, f) . (Compare the case of refinement by a mesh in Terminology 5.2.27. As before we often treat the embedding map itself as implicit.) —

We may now insist that a tame embedding admit a refinement, not by any old tame stratification but by one consisting only of transversal strata, i.e. by a manifold diagram.

DEFINITION 5.4.22 (Tame tangles). A **tame tangle** is a tame embedding of an unstratified manifold, that admits a refinement by a manifold diagram. —

More specifically, a tame tangle is an ‘ n -tame m -tangle’ when it is an n -tame embedding of an m -manifold. Unpacking that definition, an n -tame m -tangle is a tame embedding $W \hookrightarrow \mathbb{R}^n$ of an unstratified m -manifold W , such that there is a tame stratification (Z, f) (of a neighborhood Z of W), all of whose points have transversal tame singularity neighborhoods, and for which the manifold W is a union of strata of f .⁵⁰

REMARK 5.4.23 (Tame tangle terminology). One might expect a ‘tame tangle’ to be simply a tame embedding of a manifold, and to find a qualified term such as ‘transversally refinable tame tangle’ for the notion in Definition 5.4.22, i.e. a tame embedding of a manifold admitting a refinement by a tame stratification with transversal neighborhoods. However, deliberately imposing transversality as an inextricable aspect of our theory of tangles, we use the concise term for the qualified notion. \square

Recall that tame embeddings have canonical minimal coarsest refining meshes. We can consider the related notion of minimal coarsest refining manifold diagrams, as follows.

TERMINOLOGY 5.4.24 (Minimal coarsest refining manifold diagrams). For a tame tangle, a ‘minimal coarsest refining manifold diagram’ is a manifold diagram refining the tangle, such that

- (1) the diagram admits a mesh refinement that is itself a minimal coarsest refining mesh of the tangle embedding, and
- (2) the diagram cannot be strictly coarsened to another manifold diagram refining the tangle. \square

We note without proof that each tame tangle has a unique minimal coarsest refining manifold diagram. Equipped with that refinement, we may consider the resulting canonical decomposition of the tangle manifold into strata encoding distinct critical behavior under the standard projections.

TERMINOLOGY 5.4.25 (Critical refinement and critical strata). The ‘critical refinement’ of a tame tangle is the restriction to the tangle of the stratification of its minimal coarsest refining manifold diagram. The ‘critical strata’ of a tame tangle are the strata of its critical refinement. \square

REMARK 5.4.26 (Minimal coarsest diagrams via critical refinements). Recall from Remark 5.2.26 that for a tame embedding (W, g) and a choice of tame open neighborhood Z , there is a canonical coarsest stratification (Z, g_+) extending the embedding. Given a positive-codimension tame tangle $W \hookrightarrow \mathbb{R}^n$, with minimal coarsest refining manifold diagram (Z, d) , that minimal coarsest diagram is determined by the critical refinement (W, c) of the tangle, in the sense that the coarsest extension (Z, c_+) of the critical refinement is precisely the minimal coarsest diagram (Z, d) . \square

⁵⁰An equivalent, alternative formulation is that a tame tangle is a tame embedding $W \hookrightarrow \mathbb{R}^n$ of an unstratified manifold, such that there is a stratified refinement $g \rightarrow W$, for which the tame embedding $g \hookrightarrow \mathbb{R}^n$ is a constructible substratification of a tame stratification (Z, f) , all of whose points have transversal tame singularity neighborhoods.

EXAMPLE 5.4.27 (Tangles and their refining manifold diagrams). In Figure 5.48, we depict three tame tangles, along with their corresponding minimal coarsest refining manifold diagrams. Note that in all three cases, the critical point strata occur precisely at the critical points of the standard projection to \mathbb{R}^1 , and in the third case, the critical line strata trace the critical locus of the standard projection to \mathbb{R}^2 .

Reconsider also Figure 5.1 and the discussion preceding it; that illustration may be considered as a tame embedding of the unstratified 2-sphere (by merging all the point and line and surface strata in the source and target), or as a tame embedding of the 2-sphere stratified by two surface, six line, and six point strata, as shown. The unstratified version is a tame tangle, and the given stratification is, in fact, its critical refinement. The two green points are the critical points of the projection to \mathbb{R}^1 , while the blue points and the line strata are singularities (cusp and fold respectively) of the projection to \mathbb{R}^2 . (This example provides a rudimentary impression of how the critical refinement of a tame tangle encodes the classical Morse-theoretic information and the critical structure of higher-dimensional euclidean projections simultaneously.) —

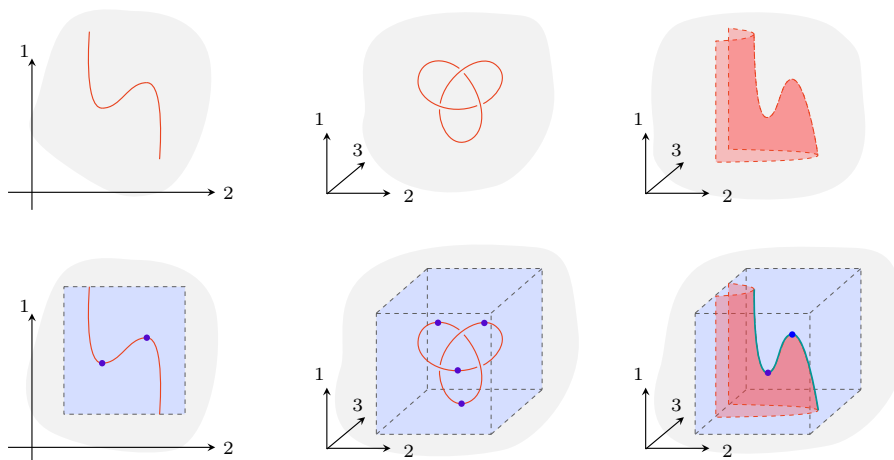

FIGURE 5.48. Tame tangles and their refining manifold diagrams.

Since tame tangles admit canonical refining manifold diagrams, and those manifold diagrams are combinatorially classified, there is an attendant

combinatorialization of tame tangles.^{51,52} Furthermore note that the notion of tame tangles extends to allow manifolds with boundary or indeed corners of any codimension.

REMARK 5.4.28 (Tangle and cobordism hypotheses). Minimal coarsest refining manifold diagrams allow interpreting tame tangles (or suitable subclasses thereof) as cellular diagrams, as explained in Remark 5.4.20. That the higher ‘bordism categories’ resulting from these diagrams encode the free higher categories with duals is the content of the cobordism and tangle hypotheses [BD95, AF17, AF24]. —

REMARK 5.4.29 (Topological versus piecewise linear versus smooth tangles). As stated and a priori, the notion of tame embedding is topological and therefore the notions of tame tangle and tame tangle singularity concern topological embeddings of topological manifolds. Of course though, for penchant or purpose, we may restrict attention to piecewise linear embeddings of piecewise linear manifolds, or smooth embeddings of smooth manifolds. These distinctions are material, even in the tame context; for instance, a generic piecewise linear embedding of the double suspension of a triangulation of the Poincaré homology sphere may be a fine tame topological tangle, but cannot be a tame piecewise linear tangle since its source is not even a piecewise linear manifold. Similarly, a generic piecewise linear embedding of the 10-dimensional Kervaire manifold may be a fine tame piecewise linear tangle, but cannot be a tame smooth tangle since its source is neither smooth nor even smoothable. —

5.4.2.2. Tangle singularities. Local neighborhoods in tame tangles will be called ‘tangle singularities’. Tame tangles are refined by manifold diagrams, and local neighborhoods in manifold diagrams are (transversal) tame singularities, thus tangle singularities are refined by tame singularities, as follows.

DEFINITION 5.4.30 (Tangle singularities). An m -tangle k -singularity is an n -tame m -tangle, for some n , whose minimal coarsest refining manifold diagram is an n -tame k -singularity. —

We typically use ‘ m -tangle singularity’, with k unspecified, to mean ‘ m -tangle 0-singularity’.

⁵¹Concisely, a tame tangle has a canonical refining manifold diagram, which is by definition a locally transversal tame stratification. That stratification is classified by a normalized stratified truss satisfying a combinatorial local transversality condition. That stratified truss has a (label) coarsening determined by the tangle, i.e. merging all the strata of the tangle embedding image. The resulting coarsely stratified truss is a ‘combinatorial tangle’, also called a ‘tangle truss’.

⁵²Note well that this particular combinatorialization, unlike the others we have previously discussed, is not entirely algorithmic, in the following sense: though each tame tangle has a corresponding tangle truss, it may not be decidable whether a given tangle truss in fact arises as the fundamental stratified truss of a tame tangle. That decidability impediment arises from the algorithmic unrecognizability of spheres.

EXAMPLE 5.4.31 (Tangle singularities in a tame 2-tangle). In Figure 5.49, we depict two tangle singularities arising as local neighborhoods in a tame 2-tangle embedding of the 2-disc. \square

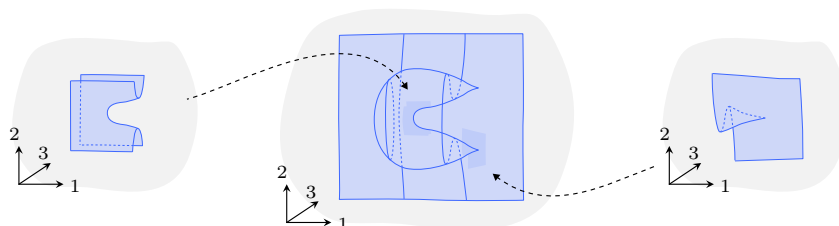

FIGURE 5.49. Two tangle singularities in a tame 2-tangle.

EXAMPLE 5.4.32 (A 3-tangle singularity). In Figure 5.50, we represent a 4-tame 3-tangle singularity $\sigma : D^3 \hookrightarrow \mathbb{R}^4$, as follows. Consider the projection $\pi_3 \circ \sigma : D^3 \rightarrow \mathbb{R}^3$ of the tangle, and the critical locus $\Gamma_3(\sigma)$ of that projection. We depict (on the left) the projection $\pi_3(\Gamma_3(\sigma)) \subset \mathbb{R}^3$ of that critical locus. (The initial slice of this 3-tangle singularity is the 2-tangle shown in the previous example. Note that due to our standard projection conventions, the 2-axis, 3-axis, and 4-axis of a 4-tame tangle correspond to the 1-axis, 2-axis, and 3-axis respectively of one of its slices considered as a 3-tame tangle.) We also depict (on the right) the projection to \mathbb{R}^3 of the critical refinement of the critical locus of the 3-tangle. The four blue surfaces and the two green lines are (images of) singular strata (fold and cusp respectively) for the projection to \mathbb{R}^3 ; whereas the orange lines are (images of) singular strata for the projection to \mathbb{R}^2 ; and the red point is (an image of) a singular stratum for the projection to \mathbb{R}^1 . \square

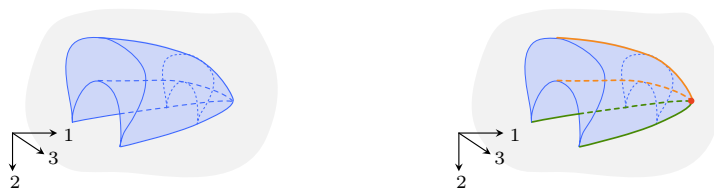

FIGURE 5.50. A projection of a 3-tangle singularity and its critical refinement.

Tangle singularities model local neighborhoods of tangles, and were just defined as tangles whose canonical manifold diagram is a singularity. Similarly, tangle isotopies will model deformations of tangles, and may be defined as tangles whose canonical manifold diagram is an isotopy. Recall that a manifold n -diagram isotopy is a manifold $(n + 1)$ -diagram not containing singularities. Tangle isotopies may also be defined more directly in terms of the absence of tangle singularities, as follows.

DEFINITION 5.4.33 (Tangle isotopy). An m -**tangle isotopy** is an n -tame m -tangle, for some n , that does not contain tangle 0-singularities. \square

More generally, an ‘ m -tangle k -isotopy’ is an n -tame m -tangle that does not contain any tangle l -singularities, for $l < k$.

EXAMPLE 5.4.34 (A 1-tangle isotopy). In Figure 5.51, we depict a 1-tangle isotopy (of 2-tame 1-tangles). Though no singularities occur, and so the 1-tangle retains certain global properties (for instance the number of critical points for the projection to \mathbb{R}^1), nevertheless the framed configuration of its component singularities changes as indicated. \square

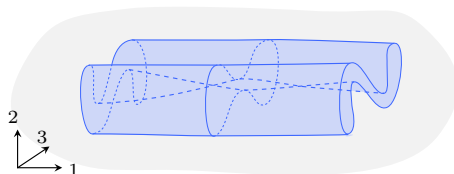

FIGURE 5.51. A 1-tangle isotopy.

Equipped with a definition of singularities, and especially with a faithful combinatorial model of them, naturally we are inclined to taxonomy. The most definitive question one may ask about a tangle singularity is whether or not it can be perturbed into a tangle that decomposes as a collection of simpler singularities. To make that question precise, we need a notion of perturbation, as follows.

TERMINOLOGY 5.4.35 (Tame tangle perturbation). For an unstratified m -manifold W and tame tangles $\iota : W \hookrightarrow \mathbb{R}^n$ and $\kappa : W \hookrightarrow \mathbb{R}^n$, a ‘tame tangle perturbation’ $\iota \rightarrow \kappa$ is a tame bundle embedding of the stratified bundle $W \times \|[1]\| \rightarrow \|[1]\|$ over the standard stratified interval $\|[1]\|$, whose special fiber is ι and whose generic fiber is κ . \square

Of course a perturbation of a tangle singularity is just a perturbation of tame tangles whose special fiber is a tangle singularity; note that the generic fiber need not be itself a tangle singularity.

Having perturbed a tangle singularity to a tangle, the consideration remains whether the singularity fragments of that tangle are simpler than the original singularity; for that one needs a notion of complexity. Happily, the combinatorial model provides ample framework for gauging complexity. For instance, if nothing else, we could set the complexity of a singularity to be the cardinality of the corresponding normalized stratified truss; similarly, we could set the complexity of a tangle to be the maximum of the complexities of its singularities. For any given definite formalization of complexity, we may investigate which singularities can be simplified (i.e. perturbed into simpler tangles) and which cannot; more broadly we may contemplate which measures

of complexity lead to an elegant and effective classification of unsimplifiable combinatorial singularities.⁵³

EXAMPLE 5.4.36 (Perturbation of a tangle singularity). In Figure 5.52, we depict a perturbation of the monkey saddle singularity into a tangle having two ordinary saddles as its singularities. By any reasonable measure, the ordinary saddle is simpler than the monkey saddle, and so the monkey saddle can, in that sense, be simplified. \square

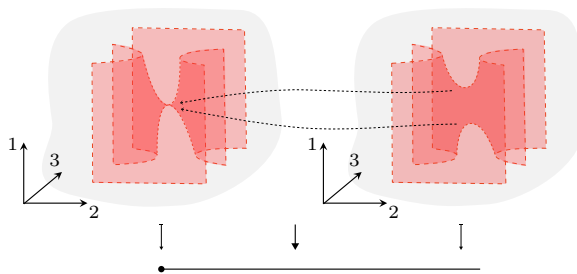

FIGURE 5.52. A perturbation of the monkey saddle into two ordinary saddle singularities.

It is not the case that an unsimplifiable singularity necessarily admits no pertinent perturbation to another equally or more complex singularity; we might want then to further concentrate on singularities that are at once unsimplifiable and imperturbable.⁵⁴ Those singularities certainly provide a reasonable and countably classifiable collection of singularities in all dimensions. Given such a collection or another suitably general class of singularities, the hope or maybe dream would be that the class is universal, in the sense that any tangle can be perturbed into one whose component singularities are in the class.

We leave to the future the ambition and challenge of classifying codimension-1 tame tangle singularities in general, and perhaps establishing some definite relationship between them and classical singularities. Even more daunting is the task of classifying higher-codimension tame tangle singularities; here even a local singularity may have a knotted or worse exotic link.⁵⁵

⁵³We leave the awkward and inexplicit term ‘unsimplifiable’, in part, to dissuade presumptions concerning the relationship to such classical properties as elementarily, irremovability, simplicity, and stability for instance [Arn75, Tho75].

⁵⁴For low-dimension codimension-1 tangles, we expect a version of unsimplifiable and imperturbable singularities to recover familiar collections, for instance the Morse singularities from projections to \mathbb{R}^1 [Mil63], the Cerf singularities from projections to \mathbb{R}^2 [Cer70], and the singularities arising from projections to \mathbb{R}^3 [Dou08], recursively interleaved with one another and variously incarnated with respect to the complete flag frame foliation.

⁵⁵One can undertake a similar taxonomic program for tangle isotopies (though this is, in some sense, less imperative, because isotopies of given tangles are algorithmically recognizable). There it seems appropriate to consider isotopies that are suitably irreducible

5.4.2.3. Smooth structures. Given a tame tangle, we can take stock of its local singularities and record the combinatorial models of those components along with the combinatorial arrangement of them, as prescribed by the intervening isotopies. Conversely, from a cabinet of combinatorial singularities, we can retrieve a suitable selection and compound them to form a tame tangle. The tangles so combinatorially constructed appear (for instance in the geometric realization of a classifying stratified truss) rather piecewise linear in character. However, we believe that this *combinatorial* description of a tangle in fact faithfully encodes a *smooth* structure on it. Of course, classical combinatorial or piecewise-linear representations do not and cannot capture smooth structures; it is therefore essential that the representation in question is *framed* combinatorial. We make our belief precise in the following form.

CONJECTURE 5.4.37 (Framed combinatorial equivalence implies diffeomorphism). *When two smooth tame tangles $\iota : M \hookrightarrow \mathbb{R}^n$ and $\iota' : M' \hookrightarrow \mathbb{R}^n$ have isomorphic associated tangle trusses, there is a diffeomorphism $M \cong M'$ between the domain manifolds.*

The plausibility of this assertion arises in part from the rigid structure of tame stratifications, as follows. Given a classifying tangle truss, the associated stratified mesh is built up constructively and inductively from stratified bundles with 1-dimensional fibers stratified by points and intervals; the tame tangle is perforce the combinatorially specified constructible union of some of those points and intervals. Certainly no exotic choices arise from automorphisms of these elementary fibers; one need only trust that there is at most one way to smooth a constructible multi-parameter union of such rigid pieces.⁵⁶ A complementary, informal rationale comes from the presumption that the local framed smooth automorphism group has the same homotopy type as the local framed piecewise-linear automorphism group; integrating that equivalence could provide a comparison of global automorphism groups ensuring that the translation from smooth framed tangles to piecewise linear framed tangles is an injective process.

Supposing then that framed combinatorial topology faithfully encodes smooth structures, the remaining concern is whether any smooth structure can be so encoded. For that it suffices to know that any smooth embedding is isotopic to a smooth tame tangle embedding. We believe that is the case, even insisting that the isotopy be arbitrarily small and itself smooth. Presumably that much would be established by using suitably framed and

and imperturbable, and again to hope that such a collection is accordingly universal. For low-dimension codimension-2 such isotopies, one finds the type II and type III Reidemeister moves, and the Roseman moves [Ros98], excepting the ones involving creation or annihilation of type I Reidemeister moves. A complete understanding, especially as the tangle dimension increases, remains of course outstanding.

⁵⁶Exotic smooth structures will arise, not from local modifications, but rather from global alterations of the singularities and isotopies and their combinatorial configuration.

stratified versions of classical transversality techniques. The result, in its most essential and relevant form, might be as follows.

CONJECTURE 5.4.38 (Smooth embedded manifolds are isotopic to tame tangles). *Any smooth embedding $i : M \hookrightarrow \mathbb{R}^n$, of a compact smooth manifold into euclidean space, is isotopic to a smooth tame tangle $\iota : M \hookrightarrow \mathbb{R}^n$.*

Those two conjectures would complete at least the adumbration of a faithful and completely combinatorial model for smooth structures on manifolds.

APPENDIX A

Linear and affine frames

This appendix provides some motivational context concerning various notions of frames, not on combinatorial objects but on classical linear and affine spaces.

In [Section A.1.1](#), we observe that linear orthonormal frames may be reformulated either in terms of sequences of linear subspaces, yielding a notion of *indframes*, or in terms of sequences of linear projections, yielding a notion of *proframes*. Though the notion of orthonormal frame depends on a euclidean structure on the vector space, neither the notion of indframe nor proframe does. We then define not-necessarily-orthonormal frames to be *orthoequivalent* when they induce the same indframe or equivalently proframe; orthoequivalence classes of frames thus provide an effective generalization of orthonormal frames to non-euclidean vector spaces.

In [Section A.1.2](#), we expand attention to three generalized notions of linear frames; an ordinary frame on a vector space corresponds to a trivialization $V \xrightarrow{\sim} \mathbb{R}^m$, but we may also consider

- › projections $V \twoheadrightarrow \mathbb{R}^k$, leading to notions of *partial* trivializations and frames,
- › injections $V \hookrightarrow \mathbb{R}^n$, leading to notions of *embedded* trivializations and frames, or
- › arbitrary linear maps $V \rightarrow \mathbb{R}^n$, leading to notions of *embedded partial* trivializations and frames.

Pushing out the reformulations and the generalizations of frames provides further notions of partial, embedded, and embedded partial indframes and proframes, and eventually a notion of orthoequivalence classes of generalized trivializations that constitutes an effective substitute for partial, embedded, or embedded partial orthonormal frames even in the absence of a euclidean structure.

Finally in [Section A.2](#), we briefly discuss the *affine* space analogs of the preceding assortment of linear space concepts. We highlight the crucial asymmetry between affine linear projections and affine linear injections, that leads to a fundamental preferencing for affine proframes over affine indframes. We conclude by emphasizing the conceptual throughline from orthonormal embedded linear frames, to orthoequivalence classes of embedded linear trivializations, to embedded linear proframes, to embedded affine proframes, to embedded simplicial proframes, to embedded simplicial frames, thus back to the starting point for framed combinatorial topology.

A.1. Linear frames

In this section we describe several notions of frame structures on linear vector spaces. We first reformulate linear orthonormal frames in terms of indframes and proframes, and consider orthoequivalence classes of trivializations as an adaptation of orthonormal frames to non-euclidean vector spaces. We then generalize these structures to partial, embedded, and embedded partial trivializations and frames, and discuss the orthoequivalence classes of such trivializations as a functional substitute for orthonormal generalized frames.

A.1.1. Linear trivializations, frames, indframes, and proframes. We recall linear trivializations and linear frames of vector spaces, and introduce the related notions of *linear indframes* and *linear proframes*. For euclidean vector spaces, oriented indframes and oriented proframes provide the same information as orthonormal frames, but indframes and proframes provide a suitable generalization of orthonormal frames to arbitrary vector spaces. The combinatorial analog of proframes in particular plays a pervasive inspirational and technical role in our development of framed combinatorial structures.

We begin with classical linear trivializations and frames.

DEFINITION A.1.1 (Linear trivializations). A **linear trivialization** of an m -dimensional vector space V is a linear isomorphism $V \xrightarrow{\sim} \mathbb{R}^m$. \square

Preimages of the standard basis vectors $e_i \in \mathbb{R}^m$ under the linear trivialization map define an ordered list of ‘frame vectors’ $v_i \in V$. Every linear trivialization therefore determines and is determined by a linear frame in the following sense.

DEFINITION A.1.2 (Linear frames). A **linear frame** of an m -dimensional vector space V is an ordered list $(v_1, v_2, \dots, v_m) \subset V$ of linearly independent vectors. \square

We now want to compare the structure of linear trivializations (and equivalently of linear frames) on vector spaces to the following two structures.

DEFINITION A.1.3 (Linear indframes). A **linear indframe** on an m -dimensional vector space V is a sequence of inclusions of vector spaces V_i , with $\dim(V_i) = i$:

$$0 = V_0 \hookrightarrow V_1 \hookrightarrow V_2 \hookrightarrow \dots \hookrightarrow V_{m-1} \hookrightarrow V_m = V. \quad \square$$

DEFINITION A.1.4 (Linear proframes). A **linear proframe** on an m -dimensional vector space V is a sequence of projections of vector spaces V^i , with $\dim(V^i) = i$:

$$V = V^m \twoheadrightarrow V^{m-1} \twoheadrightarrow V^{m-2} \twoheadrightarrow \dots \twoheadrightarrow V^1 \twoheadrightarrow V^0 = 0. \quad \square$$

OBSERVATION A.1.5 (Equivalence of indframes and proframes). Note that linear indframes and proframes define the same structure on a vector space. For a linear indframe $\{V_i \hookrightarrow V_{i+1}\}_{0 \leq i < m}$ on V , the corresponding

proframe is determined by the cokernels of the sequence of inclusions into the total vector space:

$$(V \twoheadrightarrow V^{m-i}) := \text{coker}(V_i \hookrightarrow V).$$

Conversely, for a linear proframe $\{V^i \twoheadrightarrow V^{i-1}\}_{0 < i \leq m}$ on V , the corresponding indframe is determined by the kernels of the sequence of projections from the total vector space:

$$(V_i \hookrightarrow V) := \ker(V \twoheadrightarrow V^{m-i}).$$

An illustration is given in Figure A.1. —

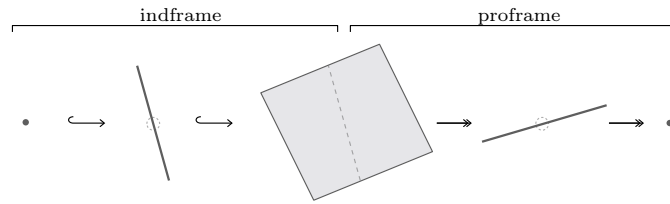

FIGURE A.1. A corresponding indframe and proframe.

There are two important standard instances of indframes and proframes.

TERMINOLOGY A.1.6 (The standard euclidean indframe). The ‘standard euclidean indframe’ of \mathbb{R}^n is the sequence of subspace inclusions

$$0 \hookrightarrow \mathbb{R} \hookrightarrow \mathbb{R}^2 \hookrightarrow \dots \hookrightarrow \mathbb{R}^{n-1} \hookrightarrow \mathbb{R}^n$$

where $\mathbb{R}^{i-1} \hookrightarrow \mathbb{R}^i$ is the inclusion as the subspace with first coordinate being zero. —

TERMINOLOGY A.1.7 (The standard euclidean proframe). The ‘standard euclidean proframe’ of \mathbb{R}^n is the sequence of projections

$$\mathbb{R}^n \twoheadrightarrow \mathbb{R}^{n-1} \twoheadrightarrow \mathbb{R}^{n-2} \twoheadrightarrow \dots \twoheadrightarrow \mathbb{R}^1 \twoheadrightarrow \mathbb{R}^0$$

where $\mathbb{R}^i \twoheadrightarrow \mathbb{R}^{i-1}$ forgets the last component of vectors in \mathbb{R}^i . —

The standard 3-dimensional indframe and proframe are illustrated in Figure A.2.

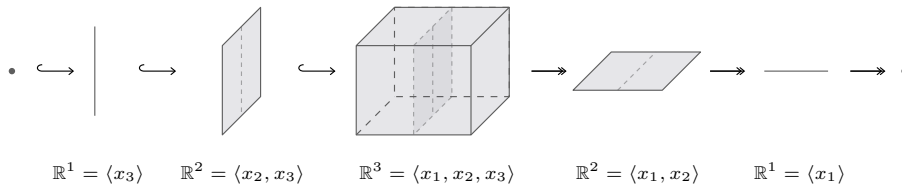

FIGURE A.2. The standard indframe and proframe.

Note that the complement of the image of each standard indframe inclusion

$$\mathbb{R}^{n-i} = \langle x_{i+1}, \dots, x_n \rangle \hookrightarrow \mathbb{R}^{n-i+1} = \langle x_i, \dots, x_n \rangle$$

has two components

$$\mathbb{R}^{n-i+1} \setminus \mathbb{R}^{n-i} = \epsilon_i^- \sqcup \epsilon_i^+,$$

where the ‘negative’ component ϵ_i^- and ‘positive’ component ϵ_i^+ consist of points with i -th numeral coordinate x_i negative and positive, respectively; we let ϵ_i^- and ϵ_i^+ also refer to the images (under the standard indframe inclusions) of these components in the total euclidean space \mathbb{R}^n . This assignment of signs to those components gives the standard indframe its standard ‘orientation structure’; an orientation of an indframe more generally is such an assignment of signs to the complementary components, as follows.

TERMINOLOGY A.1.8 (Oriented indframe). An ‘oriented indframe’ on a vector space V is an indframe $\{V_{i-1} \hookrightarrow V_i\}$ together with an association ν_i^\pm of signs to the connected components of the complement of the image of each inclusion: $V_{m-i+1} \setminus V_{m-i} = \nu_i^- \sqcup \nu_i^+$. (We let ν_i^- and ν_i^+ also refer to the images, under the indframe inclusions, of these components in the total vector space V .) —

An orientation structure on an indframe is equivalent to having an oriented vector space structure on each subspace V_i .

Note that the fiber $\pi_i^{-1}(0)$ over $0 \in \mathbb{R}^{i-1}$ of each standard proframe projection $\pi_i : \mathbb{R}^i \rightarrow \mathbb{R}^{i-1}$ is \mathbb{R} , and so $\pi_i^{-1}(0) \setminus 0$ has again a ‘negative’ component $\epsilon_-^i = \mathbb{R}_{<0} \subset \pi_i^{-1}(0)$ and a ‘positive’ component $\epsilon_+^i = \mathbb{R}_{>0} \subset \pi_i^{-1}(0)$. That assignment of signs gives the standard proframe its standard ‘orientation structure’; for a general proframe the corresponding notion is as follows.

TERMINOLOGY A.1.9 (Oriented proframe). An ‘oriented proframe’ on a vector space V is a proframe $\{p_i : V^i \twoheadrightarrow V^{i-1}\}$ together with an association ν_\pm^i of signs to the connected components of the complements $p_i^{-1}(0) \setminus 0 = \nu_-^i \sqcup \nu_+^i$. —

An orientation structure on a proframe is equivalent to an oriented vector space structure on each quotient V^i .

Our earlier correspondence of indframes $\{V_i \hookrightarrow V_{i+1}\}$ and proframes $\{p_i : V^i \twoheadrightarrow V^{i-1}\}$ on an m -dimensional vector space V extends to the oriented case. We will write $p_{>i}$ for the composite projection

$$p_{>i} := p_{i+1} \circ \dots \circ p_{m-1} \circ p_m : V \twoheadrightarrow V^i.$$

An orientation structure on the indframe determines an orientation structure on the corresponding proframe, and vice versa, by setting

$$\begin{aligned} \nu_\pm^i &:= p_{>i}(\nu_i^\pm), \\ \nu_i^\pm &:= p_{>i}^{-1}(\nu_\pm^i). \end{aligned}$$

(This correspondence is illustrated later in Figure A.3.)

The standard indframe of \mathbb{R}^m can be transported across a trivialization $V \xrightarrow{\simeq} \mathbb{R}^m$, by pulling back the standard subspaces, to give an indframe on the vector space V , and indeed any indframe on V can be obtained this way. Similarly, the standard proframe of \mathbb{R}^m can be transported across a trivialization $V \xrightarrow{\simeq} \mathbb{R}^m$, by composing with the standard projections. These transports are special cases of the following more general constructions, which will be useful later when we consider partial and embedded indframes and proframes.

TERMINOLOGY A.1.10 (Pullback sequence). Given a sequence of vector space inclusions $\{W_i \hookrightarrow W_{i+1}\}$ and a map $F : V \rightarrow W_j$, as shown below, we obtain a ‘pullback sequence’ of inclusions $\{V_i \hookrightarrow V_{i+1}\}$ by iterated pullback:

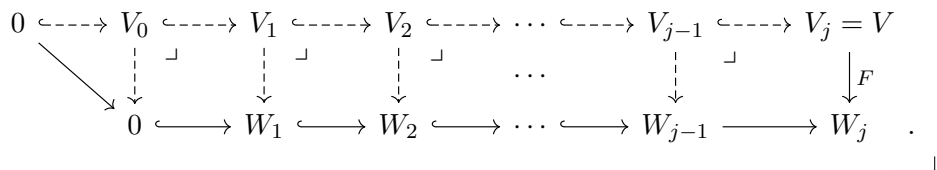

TERMINOLOGY A.1.11 (Restriction sequence). Given a sequence of vector space projections $\{W^i \twoheadrightarrow W^{i-1}\}$ and a map $F : V \rightarrow W^j$, as shown below, we obtain a ‘restriction sequence’ of projections $\{V^{i+1} \twoheadrightarrow V^i\}$ by iterated image factorization:

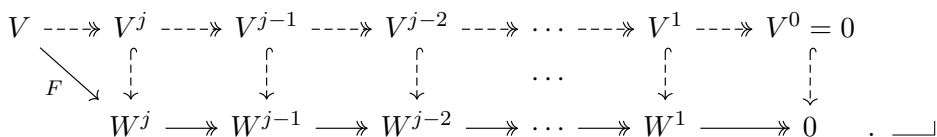

OBSERVATION A.1.12 (Trivializations induce oriented indframes and proframes). A trivialization $F : V \xrightarrow{\simeq} \mathbb{R}^m$ induces an oriented indframe on V by taking the pullback sequence of the standard indframe of \mathbb{R}^m along the map F . Similarly a trivialization $F : V \xrightarrow{\simeq} \mathbb{R}^m$ induces an oriented proframe on V by taking the restriction sequence of the standard proframe of \mathbb{R}^m along the map F . Note that when you take the proframe induced by a trivialization, and then take the corresponding indframe in the sense of Observation A.1.5, you obtain exactly the indframe induced by the trivialization. This indframe inherits an orientation ν_i^\pm from the standard orientation of \mathbb{R}^m by requiring $F(\nu_i^\pm) = \epsilon_i^\pm$.

Note well that distinct linear trivializations may induce the same oriented indframe (or equivalently the same oriented proframe). Considering when trivializations induce the same oriented indframe provides the following equivalence relation.

DEFINITION A.1.13 (Orthoequivalence). Two linear trivializations of the same vector space are **orthoequivalent** if they induce the same oriented indframe, or equivalently the same oriented proframe. \square

When the vector space has a euclidean structure, each orthoequivalence class of linear trivializations corresponds to a unique orthonormal frame, and so we have the following correspondence.

OBSERVATION A.1.14 (Orthonormal frames, oriented indframes, and oriented proframes are equivalent). Recall that when V is an m -dimensional euclidean vector space, an orthonormal frame is a linear frame whose vectors are orthogonal and of unit length. A frame is orthonormal exactly when its corresponding trivialization is an isometry. Any oriented indframe on V is induced by exactly one isometry $F : V \xrightarrow{\sim} \mathbb{R}^m$, namely the one such that $F(\nu_i^\pm) = \epsilon_i^\pm$. Similarly, any oriented proframe is induced by exactly one isometry. Thus, isometric trivializations and orthonormal frames both correspond precisely to oriented indframes and oriented proframes. This correspondence is illustrated in Figure A.3. \square

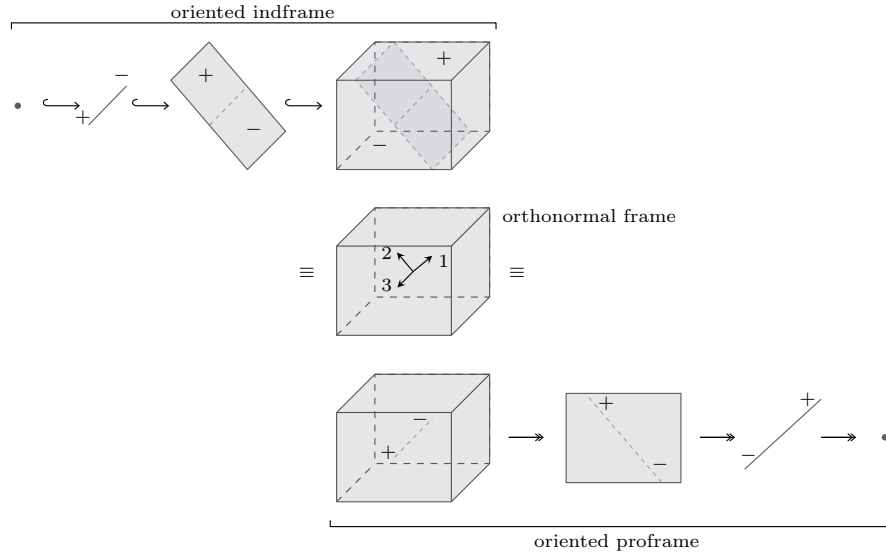

FIGURE A.3. An orthonormal frame and its corresponding oriented indframe and oriented proframe.

REMARK A.1.15 (Orthoequivalence generalizes orthonormality). As discussed, for a euclidean vector space, orthoequivalence classes of trivializations correspond to orthonormal frames, but the former notion is well defined in the absence of a euclidean structure and so provides an effective generalization of orthonormal frames to arbitrary vector spaces. \square

A.1.2. Partial and embedded trivializations and frames. Instead of considering linear trivializations $V \xrightarrow{\sim} \mathbb{R}^m$, we may relax our attention to projections $V \twoheadrightarrow \mathbb{R}^k$ or injections $V \hookrightarrow \mathbb{R}^n$ or indeed general linear maps $V \rightarrow \mathbb{R}^n$; these provide notions of ‘partial’, ‘embedded’, and ‘embedded partial’ trivializations. We next describe the related generalized notions of frames, indframes, and proframes. The combinatorial analogs of these generalizations, especially of the notion of embedded proframes, will be essential to our development of framed combinatorial complexes that involve gluing structures of different dimensions.

We start with the case of partial trivializations $V \twoheadrightarrow \mathbb{R}^k$ and the related partial frames.

DEFINITION A.1.16 (Linear partial trivializations). A **linear k -partial trivialization** of an m -dimensional vector space V is a linear projection $V \twoheadrightarrow \mathbb{R}^k$. —

DEFINITION A.1.17 (Linear partial frames). A **linear k -partial frame** of an m -dimensional vector space V is an ordered list (v_1, v_2, \dots, v_k) of k linearly independent vectors in V . —

OBSERVATION A.1.18 (Comparison of partial trivializations and partial frames). If the vector space has a euclidean structure, there is a bijective correspondence between *isometric* partial trivializations and *orthonormal* partial frames, as follows.

Given an isometric partial trivialization $V \twoheadrightarrow \mathbb{R}^k$ (i.e. one that is isometric on the orthogonal complement of the kernel), consider the unique isometric section $\mathbb{R}^k \hookrightarrow V$ (i.e. whose image is the orthogonal complement of the kernel of the trivialization); the image of the standard frame of \mathbb{R}^k under this section is an orthonormal partial frame of V .

Conversely, an orthonormal partial frame (v_1, v_2, \dots, v_k) of V determines an isometry $\mathbb{R}^k \hookrightarrow V$ sending the standard basis to the partial frame; the resulting partial isometry $V \twoheadrightarrow \mathbb{R}^k$, that splits $\mathbb{R}^k \hookrightarrow V$ and whose kernel is the orthogonal complement of the image of $\mathbb{R}^k \hookrightarrow V$, is an isometric partial trivialization. (This correspondence is illustrated later in Figure A.4.)

In the absence of a euclidean structure, there is no longer a precise correspondence of partial trivializations and partial frames. We may nevertheless think of a partial frame (v_1, v_2, \dots, v_k) as ‘compatible’ with a partial trivialization $V \twoheadrightarrow \mathbb{R}^k$ if the map $\mathbb{R}^k \hookrightarrow V$ associated to the partial frame is a section of the trivialization. This compatibility is, though, by no means a bijective correspondence. —

Next we consider the case of embedded trivializations $V \hookrightarrow \mathbb{R}^n$ and the related embedded frames.

DEFINITION A.1.19 (Linear embedded trivialization). A **linear n -embedded trivialization** of an m -dimensional vector space V is a linear inclusion $V \hookrightarrow \mathbb{R}^n$. —

DEFINITION A.1.20 (Linear embedded frame). A **linear n -embedded frame** of an m -dimensional vector space V is an ordered list (v_1, v_2, \dots, v_n) of n vectors in V , exactly m of which are nonzero, and such that the nonzero vectors are linearly independent. \square

OBSERVATION A.1.21 (Comparison of embedded trivializations and embedded frames). If the vector space has a euclidean structure, then there is a many-to-one correspondence of *isometric* embedded trivializations and *orthonormal* embedded frames, as follows.

Given an isometric embedded trivialization $V \hookrightarrow \mathbb{R}^n$, consider the partial isometry $\phi : \mathbb{R}^n \twoheadrightarrow V$, whose kernel is the orthogonal complement of the image of the trivialization. Take the vectors $(\phi(e_1), \phi(e_2), \dots, \phi(e_n)) \subset V$ and set to zero those vectors that are in the span of the preceding vectors; call the resulting embedded frame $(v_1, v_2, \dots, v_n) \subset V$. From this, construct an orthonormal embedded frame (w_1, w_2, \dots, w_n) as follows: if v_i is zero, let w_i be zero, otherwise set w_i to be the unique (suitably signed) unit vector orthogonal to $\langle v_{i+1}, \dots, v_n \rangle$ inside $\langle v_i, \dots, v_n \rangle$. Note well, this association, from an isometric embedded trivialization to an orthonormal embedded frame, is far from injective. (The association is illustrated later in Figure A.5.)

Conversely, given an embedded frame $(v_1, v_2, \dots, v_n) \subset V$ all of whose nonzero vectors are orthonormal, there is an associated isometric embedded trivialization $V \hookrightarrow \mathbb{R}^n$ sending the nonzero $v_i \in V$ to the standard basis vectors $e_i \in \mathbb{R}^n$. Note well that this embedded trivialization is ‘axial’ in the sense that its image is the span of a subset of the standard basis of euclidean space. Needless to say, this association therefore only hits a very special subset of all embedded trivializations.

In the absence of a euclidean structure, there is no longer such a definite correspondence between embedded trivializations and embedded frames. However, there remains a notion of ‘compatibility’ between embedded trivializations and embedded frames; that notion will be described later in Definition A.1.28 using induced proframes. \square

Finally, there is a common generalization of partial trivializations and embedded trivializations, and an analogous notion of frames, as follows.

DEFINITION A.1.22 (Linear embedded partial trivializations). A **linear n -embedded k -partial trivialization** of an m -dimensional vector space V is a linear map $V \rightarrow \mathbb{R}^n$ with k -dimensional image. \square

DEFINITION A.1.23 (Linear embedded partial frames). A **linear n -embedded k -partial frame** of an m -dimensional vector space V is an ordered list of n vectors $(v_1, v_2, \dots, v_n) \subset V$, exactly k of which are nonzero, and such that the nonzero vectors are linearly independent. \square

As in the previous cases, these generalized trivializations do not correspond in a faithful way to these generalized frames, even when there is a euclidean structure. (Nevertheless, there will be a correspondence, mentioned

below, of orthoequivalence classes of embedded partial trivializations and orthonormal embedded partial frames; this is illustrated later in Figure A.6.)

The failure of the correspondence of embedded partial trivializations and embedded partial frames can be somewhat remedied by working with suitably orthonormal frames and considering the trivializations up to a suitable notion of orthoequivalence. As in the case of ordinary frames, the notion of orthoequivalence will be based on (now generalized) notions of indframes and proframes, which we introduce presently.

Given a partial trivialization $V \twoheadrightarrow \mathbb{R}^k$, an n -embedded trivialization $V \hookrightarrow \mathbb{R}^n$, or an n -embedded partial trivialization $V \rightarrow \mathbb{R}^n$, we may form the pullback sequence, along the trivialization, of the standard euclidean indframe. Sequences of inclusions obtained in this way respectively give notions of partial, embedded, and embedded partial indframes, as follows.

DEFINITION A.1.24 (Linear partial, embedded, and embedded partial indframes). A **linear k -partial indframe** on an m -dimensional vector space V is a sequence of the following form (where $\dim(V_i) = i$):

$$0 \hookrightarrow V_{m-k} \hookrightarrow V_{m-k+1} \hookrightarrow \cdots \hookrightarrow V_{m-1} \hookrightarrow V_m = V.$$

A **linear n -embedded indframe** on an m -dimensional vector space V is a sequence of the following form (where $\dim(V_{m_i}) = m_i$, and, for each i , either $m_{i+1} = m_i + 1$ or $m_{i+1} = m_i$):

$$0 = V_0 = V_{m_0} \hookrightarrow V_{m_1} \hookrightarrow V_{m_2} \hookrightarrow \cdots \hookrightarrow V_{m_{n-1}} \hookrightarrow V_{m_n} = V_m = V.$$

A **linear n -embedded k -partial indframe** on an m -dimensional vector space V is a sequence of the following form (where $\dim(V_{k_i}) = k_i$, and for each i , either $k_{i+1} = k_i + 1$ or $k_{i+1} = k_i$):

$$0 \hookrightarrow V_{m-k} = V_{k_0} \hookrightarrow V_{k_1} \hookrightarrow V_{k_2} \hookrightarrow \cdots \hookrightarrow V_{k_{n-1}} \hookrightarrow V_{k_n} = V_m = V.$$

An n -embedded k -partial indframe on an m -dimensional vector space is simply n -embedded if $k = m$, or simply k -partial if $n = k$.

One defines ‘orientations’ as before by associating signs to the connected components of the complements $V_{k_i} \setminus V_{k_{i-1}}$ (when those complements are nonempty). —

Similarly, given a partial trivialization $V \twoheadrightarrow \mathbb{R}^k$, an n -embedded trivialization $V \hookrightarrow \mathbb{R}^n$, or an n -embedded partial trivialization $V \rightarrow \mathbb{R}^n$, we may form the restriction sequence, along the trivialization, of the standard euclidean proframe. Sequences of projections obtained in this way respectively give notions of partial, embedded, and embedded partial proframes, as follows.

DEFINITION A.1.25 (Linear partial, embedded, and embedded partial proframes). A **linear k -partial proframe** on an m -dimensional vector space V is a sequence of the following form (where $\dim(V^i) = i$):

$$V = V^m \twoheadrightarrow V^k \twoheadrightarrow V^{k-1} \twoheadrightarrow V^{k-2} \twoheadrightarrow \cdots \twoheadrightarrow V^0 = 0.$$

A **linear n -embedded proframe** on an m -dimensional vector space V is a sequence of the following form (where $\dim(V^{m_i}) = m_i$, and, for each i , either $m_{i-1} = m_i - 1$ or $m_{i-1} = m_i$):

$$V = V^m = V^{m_n} \twoheadrightarrow V^{m_{n-1}} \twoheadrightarrow V^{m_{n-2}} \twoheadrightarrow \dots \twoheadrightarrow V^{m_1} \twoheadrightarrow V^{m_0} = 0.$$

A **linear n -embedded k -partial proframe** on an m -dimensional vector space V is a sequence of the following form (where $\dim(V^{k_i}) = k_i$, and, for each i , either $k_{i-1} = k_i - 1$ or $k_{i-1} = k_i$):

$$V = V^m \twoheadrightarrow V^k = V^{k_n} \twoheadrightarrow V^{k_{n-1}} \twoheadrightarrow V^{k_{n-2}} \twoheadrightarrow \dots \twoheadrightarrow V^{k_1} \twoheadrightarrow V^{k_0} = 0.$$

An n -embedded k -partial proframe on an m -dimensional vector space is simply n -embedded if $k = m$, or simply k -partial if $n = k$.

One defines ‘orientations’ as before by associating signs to the connected components of the complements $p_{k_i}^{-1}(0) \setminus 0$, for the projections $p_{k_i} : V^{k_i} \twoheadrightarrow V^{k_{i-1}}$ (when those complements are nonempty). —

OBSERVATION A.1.26 (Equivalence of generalized indframes and proframes). In each of the above three generalized cases (namely with the adjectives ‘partial’, ‘embedded’, or ‘embedded partial’), the notions of indframe and proframe define equivalent structures on a vector space V ; one can be constructed from the other as before by taking cokernels and conversely kernels. —

We can now associate generalized indframes and proframes to generalized trivializations and thereby consider the resulting orthoequivalence relation on generalized trivializations.

OBSERVATION A.1.27 (Generalized trivializations induce corresponding indframes and proframes). By taking the pullback sequence of the standard indframe of euclidean space, a partial, embedded, or embedded partial trivialization of a vector space V induces a corresponding partial, embedded, or embedded partial indframe of V , referred to as the ‘induced indframe’. Similarly taking the restriction sequence of the standard proframe of euclidean space produces a corresponding partial, embedded, or embedded partial proframe of V , referred to as the ‘induced proframe’. Given a generalized trivialization, its induced indframe corresponds to its induced proframe. —

DEFINITION A.1.28 (Compatibility of generalized frames and trivializations). Given a generalized frame (v_1, \dots, v_n) of V and a generalized trivialization $V \rightarrow \mathbb{R}^n$, we say the frame and trivialization are **compatible** when each v_i spans the kernel of the projection $V^{k_i} \twoheadrightarrow V^{k_{i-1}}$ in the induced proframe of the trivialization. (The condition can alternatively be phrased in terms of the induced indframe.) —

DEFINITION A.1.29 (Generalized orthoequivalence of trivializations). Two partial, embedded, or embedded partial trivializations of the same vector

space are **orthoequivalent** if they induce the same oriented indframe, or equivalently, the same oriented proframe. —

Equipped with the notion of orthoequivalence of trivializations, we can now identify a tighter relationship, in the presence of a euclidean structure, between trivializations and orthonormal frames, as follows. For simplicity, we let orientations and the preservation of orientation structures be mostly implicit.

OBSERVATION A.1.30 (Orthoequivalence classes of partial trivializations correspond to orthonormal partial frames). Given a euclidean m -dimensional vector space V and a (not necessarily partial isometry) partial trivialization $V \twoheadrightarrow \mathbb{R}^k$, consider the induced partial indframe $0 \hookrightarrow V_{m-k} \hookrightarrow V_{m-k+1} \hookrightarrow \dots \hookrightarrow V_{m-1} \hookrightarrow V_m = V$. There is a unique (suitably oriented) unit vector $v_1 \in V_m$ orthogonal to V_{m-1} , and then a unique (suitably oriented) unit vector $v_2 \in V_{m-1}$ orthogonal to V_{m-2} , and so forth. The resulting partial frame (v_1, v_2, \dots, v_k) is orthonormal.

Conversely, starting with the orthonormal frame, we construct an associated isometric partial trivialization, by the procedure given in [Observation A.1.18](#). Both that constructed isometric partial trivialization and the original partial trivialization have the same induced indframe, and are therefore orthoequivalent. —

The relationship of partial trivializations, partial frames, partial indframes, and partial proframes is illustrated in [Figure A.4](#).

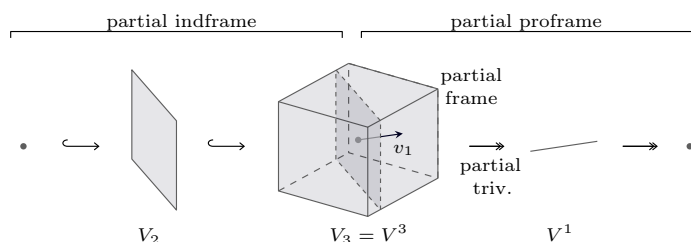

FIGURE A.4. A 1-partial trivialization, frame, indframe, and proframe.

OBSERVATION A.1.31 (Orthoequivalence classes of embedded trivializations correspond to orthonormal embedded frames). Given a euclidean m -dimensional vector space V and a (not necessarily isometric) embedded trivialization $V \hookrightarrow \mathbb{R}^n$, recall from [Observation A.1.21](#) the construction of an associated orthonormal embedded frame: consider the orthogonal projection $\phi : \mathbb{R}^n \rightarrow V$, and then take a suitable orthonormalization $(w_1, w_2, \dots, w_n) \subset V$ of the vector sequence $(\phi(e_1), \phi(e_2), \dots, \phi(e_n)) \subset V$.

Conversely, starting with the orthonormal frame $(w_1, w_2, \dots, w_n) \subset V$, define an isometric embedded trivialization $V \hookrightarrow \mathbb{R}^n$ by sending each nonzero

w_i to $e_i \in \mathbb{R}^n$, again as in Observation A.1.21. The resulting trivialization is orthoequivalent to the original one. —

The relationship of embedded trivializations, embedded frames, embedded indframes, and embedded proframes is illustrated in Figure A.5.

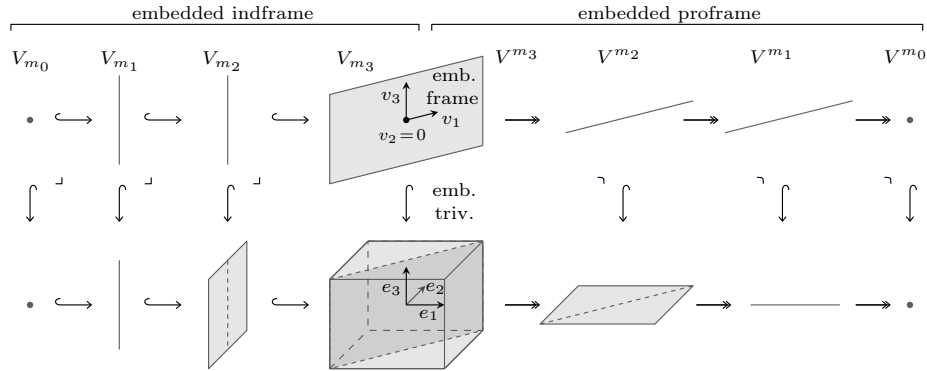

FIGURE A.5. A 3-embedded trivialization, frame, indframe, and proframe.

We leave the conceptual pushout of the two previous observations to the exhaustive reader. The correspondence is illustrated in Figure A.6.

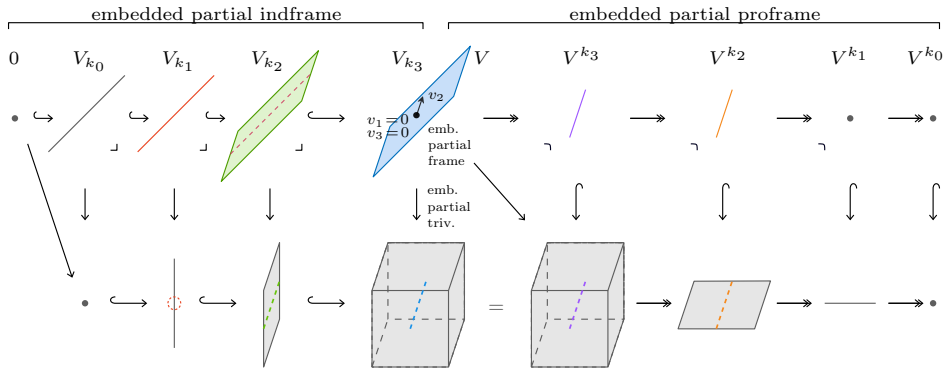

FIGURE A.6. A 3-embedded 1-partial trivialization, frame, indframe, and proframe.

REMARK A.1.32 (Orthoequivalence of generalized trivializations generalizes orthonormality). As observed, given a euclidean structure, orthoequivalence classes of embedded partial trivializations have unique embedded partial orthonormal frame representatives; that notion of orthoequivalence classes makes sense, though, in the absence of euclidean structure and so provides an effective substitute for orthonormality of generalized frames. —

A.2. Affine frames

In the previous section we discussed trivializations, frames, indframes, and proframes in the setting of linear vector spaces. We now briefly describe how these notions carry over to the case of affine linear spaces. The resulting affine linear structures constitute an instructive analog for a number of the core affine combinatorial structures developed in the text proper; we leave the detailing of that analogy, though, almost entirely to the reader's imagination.

TERMINOLOGY A.2.1 (Affine spaces and their maps). An 'affine space' \mathcal{V} is a space freely and transitively acted upon by a vector space $\vec{\mathcal{V}}$, called the 'associated vector space'. Vectors in the associated vector space $\vec{\mathcal{V}}$ are called 'translations'. An 'affine map' $\mathcal{F} : \mathcal{V} \rightarrow \mathcal{W}$ of affine spaces is a continuous map such that for a necessarily unique linear map $\vec{\mathcal{F}} : \vec{\mathcal{V}} \rightarrow \vec{\mathcal{W}}$ (the 'associated vector space map') we have $\mathcal{F}(v) - \mathcal{F}(v') = \vec{\mathcal{F}}(v - v')$. Denote the category of affine spaces and affine maps by Aff . The associated vector space and associated vector space map provide a functor

$$\vec{\quad} : \text{Aff} \rightarrow \text{Vect}.$$

Of course this associated vector space functor has a canonical section, namely the functor

$$\overleftarrow{\quad} : \text{Vect} \rightarrow \text{Aff}$$

that simply forgets the origin of the vector space. —|

TERMINOLOGY A.2.2 (Geometric realizations of simplices). Given an unordered m -simplex S , its 'geometric realization' $|S|$ (also called the associated 'geometric simplex') is the subspace, of the free vector space $\mathbb{R}\langle S \rangle$ (on the set of vertices of S), consisting of convex combinations of the standard basis. —|

The realization $|S|$ is contained in an affine hyperplane of $\mathbb{R}\langle S \rangle$; we denote that hyperplane $\langle S \rangle$. The affine structure of $\langle S \rangle$ restricts to a partial affine structure on $|S|$ ('partial' in the sense that the action by translations of the associated vector space $\vec{\langle S \rangle}$ is partial).

TERMINOLOGY A.2.3 (Affine maps of simplices). Given a simplex S and an affine space \mathcal{W} , an 'affine map' $|S| \rightarrow \mathcal{W}$ is a map that is the restriction of an affine map $\langle S \rangle \rightarrow \mathcal{W}$ defined on the associated affine hyperplane.⁵⁷ —|

NOTATION A.2.4 (Standard geometric simplices). We denote the geometric realization of the standard m -simplex, with vertices $\{0, 1, \dots, m\}$, by Δ^m , and refer to it as the 'standard geometric m -simplex'. —|

TERMINOLOGY A.2.5 (Space of affine vectors). Given an affine space \mathcal{V} , the 'space of affine vectors' in \mathcal{V} , denoted $\hat{\mathcal{V}}$, is the space of affine embeddings $e : \Delta^1 \hookrightarrow \mathcal{V}$, of the standard geometric 1-simplex Δ^1 into \mathcal{V} . Note that the

⁵⁷In the main text, abusing terminology, we refer to affine maps $|S| \rightarrow \mathcal{W}$, from affine realizations of simplices, as 'linear maps'.

space of affine vectors is itself an affine space (it has an action by $\vec{\mathcal{V}} \oplus \vec{\mathcal{V}}$), and note that there is a canonical affine isomorphism $\mathcal{V} \times \mathcal{V} \cong \hat{\mathcal{V}}$. Any affine map $\mathcal{F} : \mathcal{V} \rightarrow \mathcal{W}$ induces (by postcomposition) a map of spaces of affine vectors $\hat{\mathcal{F}} : \hat{\mathcal{V}} \rightarrow \hat{\mathcal{W}}$. The formation of affine vectors and affine vector maps together provide an ‘affine vector functor’ $\hat{\cdot} : \text{Aff} \rightarrow \text{Aff}$. \square

TERMINOLOGY A.2.6 (Basepoint forgetting map). Given an affine space \mathcal{V} , there is a canonical ‘basepoint forgetting’ map $\hat{\mathcal{V}} \rightarrow \vec{\mathcal{V}}$, sending an affine vector $e : \Delta^1 \hookrightarrow \mathcal{V}$ to the translation vector $e(1) - e(0)$. \square

Equipped with the above affine terminology, we may now crudely transport the notions of trivializations, frames, indframes, and proframes to the affine setting as follows.

TERMINOLOGY A.2.7 (Affine trivializations, frames, indframes, and proframes). By an ‘affine trivialization’ or ‘affine frame’ or ‘affine indframe’ or ‘affine proframe’ of an affine space \mathcal{V} , we will mean respectively a linear trivialization or linear frame or linear indframe or linear proframe of its associated vector space $\vec{\mathcal{V}}$. \square

Though these affine notions may be concisely specified as above in terms of the associated vector spaces, the concepts may also be understood more directly in terms of structures on affine spaces, as follows.

REMARK A.2.8 (Affine perspective on affine trivializations and frames). Given an affine space \mathcal{V} , an isomorphism $\mathcal{V} \xrightarrow{\sim} \bar{\mathbb{R}}^m$ of affine spaces would be a purely affine notion of ‘affine trivialization’; such an isomorphism provides a linear isomorphism $\vec{\mathcal{V}} \xrightarrow{\sim} \mathbb{R}^m$, thus an affine trivialization in the previous sense.

For an affine space \mathcal{V} , we may ask for a collection of frame vectors $v_i^x : \Delta^1 \rightarrow \mathcal{V}$, for all $x \in \mathcal{V}$, with v_i^x based at x in the sense that $v_i^x(0) = x$, and such that the frame vectors are invariant under every translation; such a collection would be a purely affine notion of ‘affine frame’. The basepoint forgetting map $\hat{\mathcal{V}} \rightarrow \vec{\mathcal{V}}$ sends such a collection of frame vectors $\{v_i^x\}$ to a linear frame of $\vec{\mathcal{V}}$, thus provides an affine frame in the previous sense. Conversely, pulling back a linear frame along the basepoint forgetting map provides a compatible collection of frame vectors based at every point of the affine space. \square

We may similarly try to express affine indframes and affine proframes in more native affine terms. However, we encounter the following obstruction.

OBSERVATION A.2.9 (Asymmetry of affine projections and injections). Given an affine space \mathcal{V} , and a *linear projection* $\vec{\mathcal{V}} \twoheadrightarrow W$ of its associated vector space, there is a canonically induced affine projection $\mathcal{V} \twoheadrightarrow \mathcal{W}$ whose associated vector space map is the given vector space projection; here \mathcal{W} is constructed as the quotient of \mathcal{V} by the action of the kernel $\ker(\vec{\mathcal{V}} \twoheadrightarrow W)$.

By contrast, given a *linear injection* $U \hookrightarrow \vec{V}$ into the associated vector space, there is no canonical candidate for a corresponding affine injection $\mathcal{U} \hookrightarrow \mathcal{V}$ (whose associated vector space map is the given vector space inclusion). In particular, given an affine projection $\mathcal{V} \twoheadrightarrow \mathcal{W}$, whose associated linear map has the kernel $\ker(\vec{V} \twoheadrightarrow \vec{W}) \hookrightarrow \vec{V}$, there is no canonical choice of ‘affine-linear kernel’ $\mathcal{U} \hookrightarrow \mathcal{V}$, whose associated vector space map is the given linear kernel. —

REMARK A.2.10 (Asymmetry of simplicial degeneracies and affine faces). The asymmetry between affine projections and affine injections has an analog in the affine combinatorics of simplices. Indeed, while all relevant projections of simplices can be accounted for by honest simplicial degeneracy maps, there are relevant ‘affine inclusions’ of simplices that simply cannot be expressed as honest simplicial face maps; those inclusions necessitate the introduction of the notion of affine face map of simplices and the related notion of affine kernel of a simplicial degeneracy. —

The mismatch between affine projections and affine inclusions may be marginally ameliorated by working with ‘basepoint-wise indframes’, as follows.

OBSERVATION A.2.11 (Basepoint-wise affine indframes). Given an affine space \mathcal{V} and an indframe $0 = \vec{V}^0 \hookrightarrow \vec{V}^1 \hookrightarrow \dots \hookrightarrow \vec{V}^m = \vec{V}$ on the associated vector space \vec{V} , we can pull the indframe back along the basepoint forgetting map $\hat{V} \rightarrow \vec{V}$, to obtain a filtration of the space of affine vectors \hat{V} ; this process, roughly speaking, bases a copy of the indframe at every point of \mathcal{V} . Still, the structure of an affine indframe cannot be encoded in any faithful and canonical way via honest affine maps into the original affine space \mathcal{V} . —

In practice, the aforementioned asymmetry makes affine proframes a *much more convenient tool* than affine indframes. In particular, we can reformulate the notion of affine proframes in natively affine terms as follows.

DEFINITION A.2.12 (Affine proframes). An **affine proframe** on an m -dimensional affine space \mathcal{V} is a sequence of surjective affine maps of the following form (where $\dim(\mathcal{V}^i) = i$):

$$\mathcal{V} = \mathcal{V}^m \twoheadrightarrow \mathcal{V}^{m-1} \twoheadrightarrow \mathcal{V}^{m-2} \twoheadrightarrow \dots \twoheadrightarrow \mathcal{V}^1 \twoheadrightarrow \mathcal{V}^0 = 0. \quad \text{—}$$

OBSERVATION A.2.13 (Correspondence between linear and affine proframes). Given an affine space \mathcal{V} and a proframe $\vec{V} = \vec{V}^m \twoheadrightarrow \vec{V}^{m-1} \twoheadrightarrow \dots \twoheadrightarrow \vec{V}^0$ on its associated vector space \vec{V} , there is a corresponding sequence of affine surjective maps, thus an affine proframe, obtained by applying the construction of [Observation A.2.9](#) to each projection in the linear proframe. Conversely, given any affine proframe on \mathcal{V} , in the sense of [Definition A.2.12](#), we obtain a linear proframe of the associated vector space \vec{V} simply by considering the associated vector space maps. —

The notion of affine proframes (as in [Definition A.2.12](#)), and the correspondence of linear and affine proframes (a la [Observation A.2.13](#)), generalize

straightforwardly to the cases of partial, embedded, and embedded partial proframes.

We may finally, tersely, trace the following motivational thread all the way from classical linear frames to our combinatorial affine frames. (For definiteness we mention the embedded frame case, though this may be specialized to ordinary frames or generalized to partial ones as desired.)

- (1) An orthonormal embedded linear frame of a vector space (as in [Definition A.1.20](#)) corresponds, by [Observation A.1.31](#), to an orthoequivalence class of embedded linear trivializations.
- (2) An orthoequivalence class of embedded linear trivializations corresponds, by [Definition A.1.29](#), to an embedded linear proframe.
- (3) An embedded linear proframe corresponds, by the embedded analog of [Observation A.2.13](#), to an embedded affine proframe.
- (4) The geometric realization of an embedded proframe on a simplex is precisely an embedded affine proframe of the affine space geometric realization of that simplex.
- (5) That embedded proframe on a simplex corresponds, by [Observation 3.2.23](#), to an embedded frame on the simplex, as in our core [Definition 1.1.40](#).

Altogether, frames on simplices provide a faithful affine combinatorial analog of classical linear frames on vector spaces.

APPENDIX B

Stratified topology

The notion of *stratified space* (or *singular space*) refers to a decomposition of a space into *strata* [Fri20, Ban07, Wei94, Pfl01], often ordered by some index of dimension or depth. Frequently, such order is enforced by working with filtrations $X_0 \subset X_1 \subset \dots \subset X_{k-1} \subset X_k$ of spaces $X = X_k$, where X_{i-1} is required to be closed in X_i . Equivalently, and more concisely, such a filtration may be expressed by a continuous function $f : X \rightarrow [k]^{\text{op}}$ (where $[k]^{\text{op}}$ is the poset $(0 \leftarrow 1 \leftarrow \dots \leftarrow k)$ topologized such that downward closed subposets are open sets); we recover X_i , for any $i \leq k$, as the preimage $f^{-1}([i]^{\text{op}})$. This formulation has been generalized by defining stratifications as continuous maps of spaces to any poset (and called, for instance, ‘ \mathcal{S} -filtered spaces’ [GM88, §III.2.1] or ‘ P -stratifications’ [Lur17, Def. A.5.1]). Note, however, that posets in the codomain of such continuous maps may contain structure that is unrelated to the decomposition of the underlying space, even when the map is surjective. In this appendix, we describe a notion of stratifications based on decompositions into strata, and formal entrance path relations between strata; the organizing posets are determined by the stratification and so faithfully represent its topological structure. This approach will be more robust and convenient for our purposes.

B.1. Stratified spaces

OUTLINE. In Section B.1.1, we introduce entrance paths, stratifications, fundamental posets, and characteristic functions. In Section B.1.2, we characterize stratifications among poset structures as connected-quotient maps. In Section B.1.3, we show that any poset structure universally factors into a stratification followed by a labeling, and we relate our notion of stratifications to P -stratifications and \mathcal{S} -filtered spaces. Finally, in Section B.1.4, we construct the stratified realization functor from posets to stratifications.

CONVENTION B.1.1 (Specialization topology). Given a preorder (P, \leq) , we regard it as a topological space with the *specialization topology*, declaring the open subsets to be those that are downward closed; a subset U is downward closed if $x \leq y$ and $y \in U$ implies that $x \in U$.⁵⁸ —

This topology is also called the *Alexandrov topology* on the preorder. Equivalently, the closed subsets are the upward closed subsets; the closure of a

⁵⁸We frequently write the relation $x \leq y$ as $x \rightarrow y$, interpreting preorders and posets as categories.

point x is the upward closure $P^{\geq x} = \{y : x \leq y\}$. A map of preorders is continuous if and only if it is order-preserving. In general, the specialization topology will not be Hausdorff or weakly Hausdorff. However, posets do belong to the category of *compactly generated spaces* [Str09] (since all first-countable spaces do); this category of compactly generated spaces is categorically convenient in that it admits a cartesian closed structure.

A category furthermore well-suited for the purposes of homotopy theory is that of compactly generated weakly Hausdorff spaces; this category admits relevant pushouts, and has a homotopy theory equivalent to that of categories of ‘cell-like’ models such as simplicial sets.

NOTATION B.1.2 (Categories of spaces). We denote by \mathbf{TOP} the category of *all* topological spaces, by $k\mathbf{Top}$ the subcategory of compactly generated spaces, and by \mathbf{Top} the subcategory of compactly generated weakly Hausdorff spaces. The category $k\mathbf{Top}$ is cartesian closed with internal hom denoted by $\mathrm{Map}(-, -)$, and this internal hom is inherited by \mathbf{Top} . \square

While we will not be, per se, concerned with the nuanced distinctions between these notions of spaces, it will be useful to keep in mind that they represent slightly different conceptions, tailored to specific purposes: for us, all underlying spaces of stratified realizations, which are cell-like spaces, will belong to \mathbf{Top} ; by contrast, posets as spaces will live in $k\mathbf{Top}$. To work in a joint setting of both cell-like and poset-like spaces we will stipulate the following.

CONVENTION B.1.3 (Compactly generated spaces). By default, all spaces are presumed to be compactly generated. \square

NOTATION B.1.4 (Specialization order). Given a topological space $X \in k\mathbf{Top}$, we denote by $\mathrm{Spcl} X$ its *specialization order*: this is the preorder whose objects are the elements of the underlying set X , and which has a morphism $x \rightarrow y$ whenever y is contained in the closure of x . (Note that $\mathrm{Spcl} X$ is a partial order when the space X is T_0 (since distinct points are then distinguished by open sets), and is the trivial order when the space X is T_1 (since singletons are then closed).) \square

Note that for a poset P we have $\mathrm{Spcl} P = P$. The specialization topology provides a functor, which is an adjoint equivalence, from finite preorders to finite topological spaces. The inverse functor is given by the specialization order functor. The equivalence is *concrete*, meaning that both the unit and counit of the adjunction are identities on underlying sets.

B.1.1. Entrance paths, stratifications, and fundamental posets.

SYNOPSIS. We introduce entrance paths, prestratifications, stratifications, and their fundamental posets and characteristic functions. We then discuss local finiteness, frontier-constructibility, and local path-connectedness conditions on stratifications.

A robust definition of stratified spaces is obtained by letting the topological decomposition of a space into strata determine the corresponding poset structure, in terms of the existence of so-called *entrance paths* between strata, as follows.

DEFINITION B.1.5 (Entrance path). Given a space X and two subspaces X_r and X_s , an **entrance path** from X_r to X_s is a path $\alpha : [0, 1] \rightarrow X$ with $\alpha([0, 1)) \subset X_r$ and $\alpha(1) \in X_s$. \square

Here, the path is thought of as *entering* from the former subspace X_r into the latter subspace X_s .

DEFINITION B.1.6 (Formal entrance path). Given a space X and two subspaces X_r and X_s , we say there exists a **formal entrance path** from X_r to X_s , when the closure of X_r has nonempty intersection with X_s . \square

In contrast to entrance paths, note that the structure of formal entrance paths is boolean: either there exists a formal entrance path between subspaces or there does not. If there is an entrance path from a subspace X_r to a subspace X_s , then there is a formal entrance path, but the converse need not hold (unless additional conditions are imposed, see Lemma B.1.31).

TERMINOLOGY B.1.7 (Formal entrance path relation of a decomposition). Consider a decomposition $\{X_s \subset X\}_{s \in \text{Dec}}$ of a space X into disjoint subspaces X_s indexed by a set Dec (that is, $X = \bigsqcup_{s \in \text{Dec}} X_s$). The ‘formal entrance path relation’ of the decomposition is the relation on the indexing set Dec that has an arrow $r \rightarrow s$ exactly when there is a formal entrance path from X_r to X_s . \square

Note that the formal entrance path relation of a decomposition is reflexive, but need not be antisymmetric or transitive (see Figures B.2 and B.3 for examples). Stratifications are exactly those decompositions for which this relation has no cycles, as follows.

DEFINITION B.1.8 (Prestratifications and stratifications). A **prestratification** (X, f) of a space X is a decomposition $f = \{X_s \subset X\}_{s \in \text{Dec}(f)}$ of X into disjoint, nonempty, and connected subspaces indexed by a set $\text{Dec}(f)$, called the ‘decomposition set’. The subspaces X_s are called **strata** of (X, f) . A **stratification** (X, f) is a prestratification such that the formal entrance path relation on the decomposition set $\text{Dec}(f)$ has no cycles. \square

NOTATION B.1.9 (Shorthand for (pre)stratifications). We frequently abbreviate a (pre)stratification (X, f) simply by f , referring to f as a ‘(pre)stratification on X ’. Moreover, we often abbreviate a stratum $X_s \subset X$ simply by its index $s \in \text{Dec}(f)$. \square

Observe that, given a stratification (X, f) , the transitive closure of the formal entrance path relation on the decomposition set $\text{Dec}(f)$ is a partially ordered set, which has an arrow $r \rightarrow s$ exactly when there is a chain of formal entrance paths beginning at r and ending at s . This does not hold

true if (X, f) is merely a *prestratification*, in which case $\text{Dec}(f)$ obtains the structure of a *preordered set*.

DEFINITION B.1.10 (Fundamental preorder and poset). For a prestratification (X, f) , the **fundamental preorder** $\mathbb{I}(f)$ is the decomposition set of the prestratification together with the transitive closure of the formal entrance path relation. If (X, f) is a stratification, then we refer to $\mathbb{I}(f)$ as the **fundamental poset** of (X, f) . —

EXAMPLE B.1.11 (Fundamental poset). Figure B.1 depicts a stratification (X, f) of the open 2-disk into five strata, along with its fundamental poset $\mathbb{I}(f)$ (with elements color-coded to indicate the corresponding strata). —

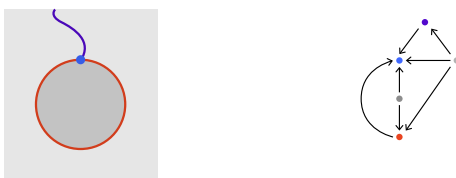

FIGURE B.1. Fundamental poset of a stratification.

EXAMPLE B.1.12 (Fundamental poset requiring transitive closure). Figure B.2 depicts a stratification of the open interval, into one open interval and two half-open interval strata, together with its fundamental poset. —

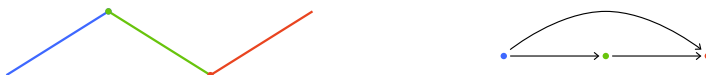

FIGURE B.2. A stratification with fundamental poset as the transitive closure of the entrance path relation.

EXAMPLE B.1.13 (Fundamental preorder). In Figure B.3, we depict a decomposition of the circle that is not a stratification but merely a prestratification, because the formal entrance path relation has a cycle. —



FIGURE B.3. A decomposition that is not a stratification but a prestratification, and its formal entrance path relation.

REMARK B.1.14 (Exit paths and the exit path preorder). Given a prestratification (X, f) , the opposite preorder $\mathbb{I}(f)^{\text{op}}$ of the fundamental preorder is called the ‘exit path preorder’. Its arrows may be understood as ‘exit paths’ (due to MacPherson, unpublished; see [Tre09]): an *exit path from X_s to X_r* is a path $p : [0, 1] \rightarrow X$ with $p(0) \in X_s$ and $p((0, 1]) \subset X_r$; the path is *exiting* from the stratum X_s into the stratum X_r . Whether to focus on entrance or exit paths is a matter of convention and convenience; see the next remark. —

REMARK B.1.15 (Entrance versus exit paths). There are two (categorically dual) conventions for the fundamental posets, and similarly for the ‘fundamental categories’, of stratifications, based on whether one chooses to work with entrance paths or exit paths in a stratified space. We choose the former convention over the latter, since it yields *covariant* descriptions of constructible bundles [AFT17, AFR19].

A preview illustration of this viewpoint is given in Figure B.4, for a stratified bundle π over a stratified circle (S^1, f) and its associated covariant functor from the fundamental category $\mathbb{I}_1(f)$ (described later, using the entrance path convention) to the category of sets. —

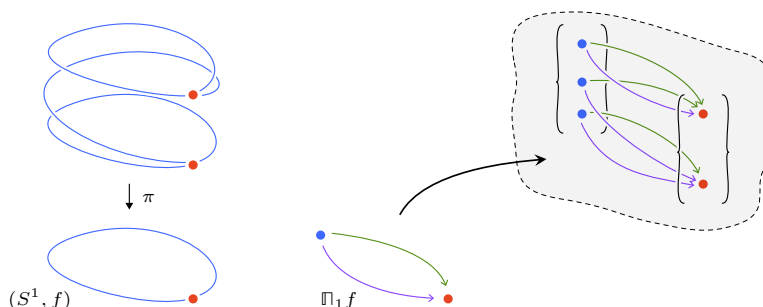

FIGURE B.4. A stratified bundle encoded as a covariant functor from its fundamental category.

REMARK B.1.16 (Fundamental posets as generalizations of connected component sets). Fundamental posets play a fundamental role in the theory of stratified spaces: they are the analog for stratified spaces of connected component sets $\pi_0 X$ of topological spaces X . —

TERMINOLOGY B.1.17 (Discrete and indiscrete stratifications). Every space X has an ‘indiscrete stratification’ whose strata are the connected components of X . The fundamental poset of the indiscrete stratification is the set of connected components of X (with discrete ordering). At the other extreme, every space has a ‘discrete prestratification’, in which each point is its own stratum. The fundamental preorder of the discrete prestratification of X is the specialization order $\text{Spcl } X$. (In particular, the definition of specialization order can be recovered from the definition of fundamental preorder). —

Unless indicated otherwise, a bare topological space is implicitly given the indiscrete stratification.

TERMINOLOGY B.1.18 (Finite (pre)stratifications). We call a (pre)stratification (X, f) ‘finite’ if its fundamental preorder $\mathbb{N}(f)$ is finite, and call it ‘infinite’ otherwise. —

DEFINITION B.1.19 (Characteristic function). Given a prestratification (X, f) , we refer to the function $X \rightarrow \mathbb{N}(f)$ sending each point $x \in X_r$ to its corresponding stratum $r \in \mathbb{N}(f)$, as the **characteristic function** of the prestratification. We denote the characteristic function of a prestratification (X, f) by $f : X \rightarrow \mathbb{N}(f)$. —

A fundamental property of characteristic functions is that they are *finitely continuous*, as follows.

TERMINOLOGY B.1.20 (Finitely continuous maps). A function of topological spaces $F : X \rightarrow Y$ is called ‘finitely continuous’ if for each finite subspace $Q \subset Y$, the function restricts to a continuous map $F : F^{-1}(Q) \rightarrow Q$. —

LEMMA B.1.21 (Finite continuity in prestratifications). *Characteristic functions of prestratifications are finitely continuous.*

PROOF. Given a prestratification (X, f) with characteristic function $f : X \rightarrow \mathbb{N}(f)$, consider a finite subposet $Q \subset \mathbb{N}(f)$, and let $U \subset Q$ be a downward closed subposet of Q (i.e. an open subspace). Arguing by contradiction, assume $f^{-1}(U) \subset f^{-1}(Q)$ is not open. Then there is a point $p \in f^{-1}(U)$ such that each neighborhood of p intersects a preimage $f^{-1}(q)$ of some $q \in Q \setminus U$. Since Q is finite, there must be a $q \in Q \setminus U$ such that $f^{-1}(q)$ intersects *all* neighborhoods of p . This means p lies in the closure of $f^{-1}(q)$. By definition of formal entrance paths there must be an arrow from q to $f(p) \in U$. But this contradicts that U is downward closed. Thus, $f^{-1}(U) \subset f^{-1}(Q)$ must be open, showing finite continuity of f . □

In the case of finite prestratifications, this of course implies that their characteristic functions are continuous in the usual sense. In fact, the continuity of the characteristic function also holds for locally finite stratifications, as follows. (From now on, we will focus most of our attention on stratifications instead of working in the more general context of prestratifications.)

DEFINITION B.1.22 (Locally finite stratifications). A stratification (X, f) is **locally finite** if every stratum s has an open neighborhood $s \subset N(s)$ that is a union of finitely many strata. —

TERMINOLOGY B.1.23 (Locally finite posets). A poset (P, \leq) is ‘locally finite’ if all downward closures $P^{\leq x} = \{y \mid y \leq x\}$ are finite. —

OBSERVATION B.1.24 (Local finiteness versus poset local finiteness). Consider the following conditions on a stratification:

- › The stratification f is locally finite.

- ▷ The fundamental poset $\mathbb{P}(f)$ is locally finite.

The first condition implies the second, but the converse need not be the case. (For instance, the discrete stratification of \mathbb{R} has a locally finite fundamental poset but is not a locally finite stratification.) However, provided we assume the characteristic function of the stratification is continuous, then the conditions are equivalent. —

The definition of local finiteness can also be phrased as a ‘pointwise local’ condition under the further assumption of so-called frontier-constructibility.

DEFINITION B.1.25 (Frontier-constructibility). A stratification (X, f) is **frontier-constructible** if the closure \bar{s} of every stratum s can be written as a union of strata in f .⁵⁹ —

The frontier-constructibility condition is also sometimes simply referred to, in the literature, as the ‘frontier condition’. In [Lemma B.2.10](#) we will show that this condition holds if and only if $f : X \rightarrow \mathbb{P}(f)$ is an open function.

OBSERVATION B.1.26 (Local finiteness versus pointwise local finiteness). Given a stratification (X, f) , consider the following two conditions.

- ▷ (X, f) is locally finite.
- ▷ (X, f) is ‘pointwise locally finite’, in the sense that any point $x \in X$ has an open neighborhood intersecting only finitely many strata.

In general, the first condition implies the second, but the second need not imply the first. If (X, f) is frontier-constructible, then the conditions become equivalent. —

LEMMA B.1.27 (Locally finite characteristic functions are continuous). *If (X, f) is a locally finite stratification, then its characteristic function $f : X \rightarrow \mathbb{P}(f)$ is continuous.*

PROOF. We show each point $x \in X$ has an open neighborhood on which f is continuous. Let $s = f(x) \in \mathbb{P}(f)$ be the stratum containing x . Using local finiteness, pick a neighborhood U of x intersecting only finitely many strata. By definition of formal entrance paths, we can shrink this to a neighborhood U' , which is contained in $f^{-1}(\mathbb{P}(f)^{\leq s})$. Continuity of f restricted to U' now follows from the finite stratified case (see [Lemma B.1.21](#)) applied to the finite substratification of f obtained from the union of strata in $\mathbb{P}(f)^{\leq s}$. □

REMARK B.1.28 (Characteristic maps). When a characteristic function is continuous we usually refer to it as a characteristic *map*. —

Note, characteristic functions of general infinite (pre)stratifications need not be continuous, as the next example illustrates.

⁵⁹The name ‘frontier-constructible’ may be thought of as a reference to the observation that in a frontier-constructible stratification, the inclusion of the closure of a stratum into the full stratification induces a constructible stratified bundle (with empty or singleton fibers).

EXAMPLE B.1.29 (Discontinuous characteristic function). In Figure B.5, we depict a stratification of the closed interval with non-continuous characteristic function. Of course the stratification is not locally finite. \square

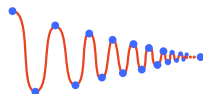

FIGURE B.5. A stratification with non-continuous characteristic function.

As we will see in Lemma B.1.40, there is a precise characterization of those functions $f : X \rightarrow P$, from a space to a finite poset, that are characteristic maps of stratifications.

Finally, let us revisit the relation of entrance paths and formal entrance paths.

DEFINITION B.1.30 (Pairwise local path-connectedness). A stratification (X, f) is called **pairwise locally path-connected** when for each pair of strata $r, s \in \mathbb{P}(f)$, the union $r \cup s \subset X$ is locally path-connected. \square

LEMMA B.1.31 (Conditions for dropping formality). *Given a pairwise locally path-connected stratification (X, f) , and a formal entrance path from r to s , there exists an entrance path starting in r and with endpoint in s . Moreover, if (X, f) is frontier-constructible, then such a path can be constructed with endpoint any given point $x \in s$.*

PROOF. For the first statement, choose an endpoint x in the intersection $\bar{r} \cap s$ and use pairwise local path-connectedness. For the second statement, note that $s \subset \bar{r}$. \square

OBSERVATION B.1.32 (Fundamental posets via entrance paths). Note that in a frontier-constructible stratification, the fundamental poset has an arrow from r to s precisely when there is a formal entrance path from r to s (i.e. the transitive closure is not needed). Let us call a stratification ‘reasonably regular’ when it is pairwise locally path-connected and also frontier-constructible. By the preceding lemma, the fundamental poset of a reasonably regular stratification has an arrow from r to s precisely when there is an (actual, not formal) entrance path from r to s . \square

B.1.2. Poset structures and quotient maps.

SYNOPSIS. We compare our definition of stratifications to the closely related but distinct notion of poset structures on spaces. We characterize quotient maps to finite posets in terms of formal entrance paths, define connected-quotient maps, and show that stratifications are precisely the connected-quotient maps among poset structures.

DEFINITION B.1.33 (Poset structures). Given a poset P , a **P -structured space** (X, f) is a space X together with a continuous map $f : X \rightarrow P$. \square

A ‘ P -structure’ is also known as a ‘ P -stratification’ in the literature. We will first show that characteristic maps of finite stratifications can be understood as a certain class of poset structures. Later we will show that, conversely, every poset structure can be universally split into a stratification followed by a labeling.

Recall, a surjective continuous map $f : X \rightarrow Y$ of spaces is a quotient map if for each subset $U \subset Y$, the subset U is open if and only if the subset $f^{-1}(U)$ is open. When Y is the specialization topology of a poset, we call the quotient map f a ‘poset quotient’. Poset quotients (to finite posets) have the following useful characterization.

NOTATION B.1.34 (Covering relation). Given a poset (P, \leq) , its covering relation is as follows: an element $x \in P$ ‘covers’ an element $y \in P$, written $y <^{\text{cov}} x$, if the relation $y < x$ is non-refinable (that is, for any $y \leq z \leq x$ we have either $y = z$ or $z = x$). —

LEMMA B.1.35 (Quotient maps to finite posets). *For a space X , a finite poset P , and a surjective continuous map $f : X \rightarrow P$, the following are equivalent:*

- (1) f is a quotient map,
- (2) for any cover $p <^{\text{cov}} p'$ in the poset P , there is a formal entrance path from $f^{-1}(p)$ to $f^{-1}(p')$.

REMARK B.1.36 (A quotient of posets is a map that is surjective on objects and on covers). When X is itself the specialization topology of a poset Q , the lemma simplifies to the following: the map $f : Q \rightarrow P$ is a quotient map if and only if f is surjective on objects and on covers. (Here, ‘surjective on covers’ means that every cover $p <^{\text{cov}} p'$ in P lifts to some $q \leq q'$ in Q with $f(q) = p$ and $f(q') = p'$; the lift can always be chosen such that it is itself a cover.) —

PROOF OF LEMMA B.1.35. For $p \in P$, define K_0^p to be the preimage $f^{-1}(p)$. Set $I_0^p = \{p\}$. Let I_1^p be the set of $q \in P$ such that $f^{-1}(q)$ intersects the closure $\overline{K_0^p}$. Note that continuity of f implies that $p \leq q$ for each $q \in I_1^p$. Define K_1^p to be the union of preimages $f^{-1}(q)$ of $q \in I_1^p$. Set I_2^p to be the set of $q \in P$ such that $f^{-1}(q)$ intersects the closure $\overline{K_1^p}$, and define K_2^p to be the union of preimages $f^{-1}(q)$ of $q \in I_2^p$. Repeating this process, since P is finite, we find an index j with $I_j^p = I_{j+1}^p$ and $K_j^p = K_{j+1}^p = \overline{K_j^p}$. Denote these sets by I^p and K^p respectively.

Assume f is a quotient map. Consider a cover $p <^{\text{cov}} p'$. We claim it is impossible that $p' \notin I^p$. Indeed, the complement $X \setminus K^p$ is the preimage of $P \setminus I^p$; since $X \setminus K^p$ is open and since f is a quotient map, it follows that $P \setminus I^p$ is open which contradicts the assumption that $p < p'$ and $p' \notin I^p$. Thus $p' \in I^p$; this implies $f^{-1}(p') \subset K^p$ (and thus intersects K^p). Then there is a sequence $p = p_0 < p_1 < \dots < p_k = p'$ with $p_i \in I_i^p$. Since $p < p'$ is a cover we must have $k = 1$, meaning $f^{-1}(p')$ intersects the closure of $f^{-1}(p)$.

Conversely, assume f is such that for any cover $p < p'$ in P , the preimage $f^{-1}(p')$ intersects the closure of the preimage $f^{-1}(p)$. Let $Q \subset P$ be a subposet. Let $I^{P \setminus Q}$ and $K^{P \setminus Q}$ be the respective unions of all I^p and K^p for each $p \in P \setminus Q$. If Q is open, then $f^{-1}(Q)$ is open by continuity of f . If $f^{-1}(Q)$ is open, then it must be disjoint from $K^{P \setminus Q}$ (by construction of $K^{P \setminus Q}$). Thus $I^{P \setminus Q} = P \setminus Q$. Note that $I^{P \setminus Q}$ is upward closed by our initial assumption. It follows that Q is downward closed, i.e. open as required. \square

A central role will be played by poset quotients whose equivalence classes are connected in the following sense.

DEFINITION B.1.37 (Connected-quotient maps). For a space X and a finite poset P , a continuous map $f : X \rightarrow P$ is a **connected-quotient map** when it is a poset quotient, for which preimages of points $p \in P$ are connected. (Note, we take ‘connected’ to also entail ‘nonempty’.) —

REMARK B.1.38 (Connected-quotient maps between posets). If Q is a poset (endowed with the specialization topology), a connected-quotient map $f : Q \rightarrow P$ in the sense of the preceding definition is simply a poset quotient whose point preimages are connected subposets of Q . —

EXAMPLE B.1.39 (Connected-quotient map). In Figure B.6 we depict maps from the circle to three different posets (by color-matching images and preimages). The first map is a connected-quotient map. The second map fails to be a quotient map though has connected preimages, while the third map is a quotient map but fails to have connected preimages. —

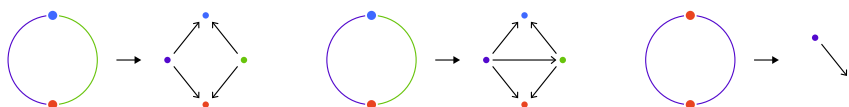

FIGURE B.6. A connected-quotient map and two non-connected-quotient maps.

We can now characterize stratifications among P -structures.

LEMMA B.1.40 (Characteristic maps are connected-quotient maps). For a space X , a finite poset P , and a P -structure $f : X \rightarrow P$, the following are equivalent:

- (1) f is the characteristic map of a stratification (that is, the decomposition of X into preimages of f is a stratification with fundamental poset $\Pi(f) = P$ and characteristic map f);
- (2) f is a connected-quotient map.

PROOF. If f is a characteristic map then, by definition, it has connected preimages and satisfies the second condition in Lemma B.1.35. Thus f is a connected-quotient map.

Conversely, if f is a connected-quotient map, then f defines a prestratification by decomposing X into the preimages of f (which are connected and nonempty by [Definition B.1.37](#)). Since P is a poset and f is continuous, the formal entrance path relation has no cycles, so this prestratification is a stratification. By [Lemma B.1.35](#), the map $f : X \rightarrow P$ is exactly the characteristic map of this stratification. \square

OBSERVATION B.1.41 (Connected-quotient maps compose). Using the definition of connected-quotient maps, note that, given a connected-quotient map $X \rightarrow P$ and a connected-quotient map $P \rightarrow Q$, their composite $X \rightarrow Q$ is another connected-quotient map. —

The previous lemma, together with this observation, implies that characteristic maps of finite stratifications compose. As we will see, composing the characteristic map of a stratification with a connected-quotient of posets corresponds to a coarsening of the stratification (see [Lemma B.2.12](#)).

The correspondence of characteristic maps and connected-quotient maps from [Lemma B.1.40](#) could be generalized to the context of infinite stratifications, by characterizing characteristic functions as *finitely* connected-quotient maps (analogous to the notion of *finite* continuity in [Lemma B.1.21](#)), but we forego a discussion of the infinite and in particular of the locally finite cases.

B.1.3. Factoring poset structures into stratifications and labelings.

SYNOPSIS. We show that any poset structure universally factors, via a connected component splitting construction, into a stratification followed by a labeling. We then summarize the relationship of our notion of stratifications to two other conventional definitions, namely P -stratifications and \mathcal{S} -filtered spaces.

TERMINOLOGY B.1.42 (Labelings). A ‘ \mathbb{C} -labeling’ (or simply a ‘labeling’) of the (pre)stratification (X, f) in the category \mathbb{C} is a functor $L : \mathbb{P}(f) \rightarrow \mathbb{C}$. When \mathbb{C} is a poset, we also call the functor L a ‘poset labeling’. —

We note the following categorical generalization: instead of considering labelings as functors from the fundamental (preorder or) poset of a (pre)stratification, one may consider functors from the fundamental category or fundamental ∞ -category, as defined later in [Definition B.3.10](#).

TERMINOLOGY B.1.43 (Specialization labelings). Let (X, f) be a finite (pre)stratification. The ‘specialization labeling’ of X associated to f is the labeling of the discrete prestratification $X \rightarrow \text{Spcl } X$ given by the functor $\text{Spcl } f : \text{Spcl } X \rightarrow \mathbb{P}(f)$ (obtained by applying the specialization order functor to the continuous map $f : X \rightarrow \mathbb{P}(f)$). —

We now show that any P -structure canonically factors as the composite of a stratification and a discrete labeling on that stratification. This factorization will be referred to as the ‘connected component splitting’ of the P -structure. Discreteness of the labeling will mean the following.

TERMINOLOGY B.1.44 (Discrete map). A map of posets $F : Q \rightarrow P$ is called a ‘discrete map’ if its preimages are discrete, i.e. for each $p \in P$ the preimage $F^{-1}(p)$ contains no non-identity arrows. Note that the condition of discreteness is equivalent to requiring F to be a conservative functor of categories $Q \rightarrow P$. \square

CONSTRUCTION B.1.45 (Connected component splittings). For a P -structure $f : X \rightarrow P$, the ‘connected component splitting’ of f is the factorization

$$f = (X \xrightarrow{\text{char}(f)} \text{cmpnt}(f) \xrightarrow{\text{discr}(f)} P)$$

as follows. Decompose X into the connected components of the preimages of f ; this defines a prestratification of X (strata are connected and nonempty by construction). Since P is a poset and f is continuous, the formal entrance path relation on the decomposition has no cycles, so this is a stratification. The map $\text{char}(f) : X \rightarrow \text{cmpnt}(f)$ is the characteristic function of this stratification, and $\text{discr}(f) : \text{cmpnt}(f) \rightarrow P$ is the discrete map sending each connected component of a preimage $f^{-1}(p)$ back to p . \square

We record three universal properties of connected component splittings: universality among connected-quotient factorizations, universality among discrete map factorizations, and uniqueness among connected-quotient and discrete map factorizations.

LEMMA B.1.46 (Universality of connected component splitting). *Let $f : X \rightarrow P$ be a P -structure. Assume f factors into maps $g : X \rightarrow Q$ and $b : Q \rightarrow P$, where g is continuous and b is a map of posets. Consider the following diagram:*

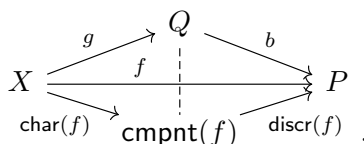

- (1) Characteristic map universality: *If g is characteristic, then there is a unique poset map $Q \rightarrow \text{cmpnt}(f)$ making the above diagram commute.*
- (2) Discrete map universality: *If b is a discrete map, then there is a unique poset map $\text{cmpnt}(f) \rightarrow Q$ making the above diagram commute.*
- (3) Combined universality: *If g is characteristic and b is a discrete map, then there is a unique poset isomorphism $Q \cong \text{cmpnt}(f)$ making the above diagram commute.*

PROOF. (1) Since g is characteristic, it has connected preimages. Thus its preimages must lie in the connected components of preimages of f . The map $Q \rightarrow \text{cmpnt}(f)$ is the inclusion of strata of g into strata of $\text{char}(f)$.

(2) We first show that preimages of g are unions of strata of $\text{char}(f)$ (i.e. connected components of preimages of f). Let Z be a connected component of a preimage of f . Let $\{q_i^Z\}_{i \in I}$ be the set of objects in Q whose preimages $r_i^Z = g^{-1}(q_i^Z)$ intersect Z . Note that, since b is assumed to be a discrete map, there are no arrows between any q_i^Z in Q . Let Q_i^Z be the downward closure of q_i^Z in Q . Since g is assumed to be continuous, we have a disjoint open cover $\sqcup_i g^{-1}(Q_i^Z) \cap Z$ of Z . Since Z is connected, the indexing set I must be of cardinality 1. This shows that preimages $g^{-1}(q)$ of g are unions of connected components Z of preimages of f . The map $\text{cmpnt}(f) \rightarrow Q$ can then be defined by mapping each stratum $Z \subset g^{-1}(q)$ back to q .

(3) This statement follows by combining statements (1) and (2). \square

Note that even if $f : X \rightarrow P$ is continuous, the characteristic function $\text{char}(f)$ need not be continuous, as illustrated in the following example.

EXAMPLE B.1.47 (Translating P -structures into stratifications). The map on the left in Figure B.6 determines a stratification. This stratification is recovered from both the P -structure in the middle and the one on the right, by connected component splitting. In particular, there are many P -structures with the same underlying stratification. In Figure B.7, we depict another P -structure (again coloring images and preimages in the same color); its connected component splitting recovers the stratification from Figure B.5 (which had non-continuous characteristic function). \square

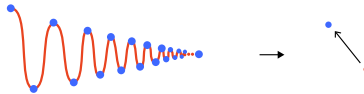

FIGURE B.7. A poset structure with non-continuous splitting.

We can finally summarize the relationship of our notion of stratifications to two other common notions, namely P -stratifications and \mathcal{S} -filtered spaces.

REMARK B.1.48 (Relation of stratifications and P -stratifications). Our notion of a P -structure, given by a continuous map from X to P , is also known as a ‘ P -stratification’ (see [Lur17, Def. A.5.1]). Given a P -stratification $f : X \rightarrow P$, we can construct a stratification with characteristic function $\text{char}(f) : X \rightarrow \text{cmpnt}(f)$, by the connected component splitting of Construction B.1.45. (Note that there may be many different P -stratifications $f : X \rightarrow P$ that produce, by this splitting, the same stratification.) Conversely, every locally finite stratification (X, f) arises as the connected component splitting of a P -stratification; indeed, by Lemma B.1.27, we can simply set $P = \mathbb{N}(f)$ and the characteristic map $f : X \rightarrow P$ will be continuous. \square

REMARK B.1.49 (Relation of stratifications and \mathcal{S} -filtered spaces). Given a poset \mathcal{S} with unique minimal element \perp , an ‘ \mathcal{S} -filtration’ of a space X is a collection of closed subsets $X_s, s \in \mathcal{S}$, such that $X_\perp = X$ and $X_s \subset X_t$ if

$s \geq t$ in \mathcal{S} (see [GM88, §III.2.1], up to opposite poset conventions). From that data, define a continuous map

$$f_{\mathcal{S}} : X \rightarrow \mathcal{S} \text{ by } f_{\mathcal{S}}(x) = t \text{ for } x \in X_t \setminus \bigcup_{s>t} X_s.$$

The connected component splitting of $f_{\mathcal{S}}$ provides a stratification, with characteristic function $\text{char}(f_{\mathcal{S}})$. Conversely, every stratification (X, f) with continuous characteristic map $f : X \rightarrow \mathbb{N}(f)$ yields a $(\mathbb{N}(f)^{\triangleleft})$ -filtration of X by setting

$$X_s = f^{-1}(\mathbb{N}(f)^{\geq s}).$$

(Here $\mathbb{N}(f)^{\triangleleft}$ is the poset obtained by adjoining a new bottom element \perp to $\mathbb{N}(f)$, and $\mathbb{N}(f)^{\geq s}$ is the upper closure of an element s in $\mathbb{N}(f)$).⁶⁰ —

B.1.4. Stratified realizations of posets.

SYNOPSIS. We construct the stratified realization of a poset, which is a canonical stratification of the geometric realization, having the poset itself as fundamental poset.

REMARK B.1.50 (Nerves of posets). Recall the ‘nerve’ NP of a poset (P, \leq) is the simplicial set whose m -simplices S are the length- m chains of composable arrows in P ; in other words, an m -simplex is a map of posets $S : [m] \rightarrow P$. The simplex $S : [m] \rightarrow P$ is called nondegenerate if it is injective. —

REMARK B.1.51 (Geometric realizations of posets). Recall the ‘geometric realization’ $|P|$ of a poset P is obtained by applying the geometric realization of simplicial sets to the nerve of P . Explicitly, the geometric realization $|P|$ is the space of functions $w : \text{obj}(P) \rightarrow \mathbb{R}_{\geq 0}$ whose support $\text{supp}(w) \subset \text{obj}(P)$ is the object set of a nondegenerate simplex in P , and whose total weight is fixed, i.e. $\sum_{p \in \text{obj}(P)} w(p) = 1$. We refer to such functions w as a ‘convex combination of objects’ of the poset. —

CONSTRUCTION B.1.52 (Stratified realizations of posets). The geometric realization $|P|$ of a poset P has a stratification $\|P\|$, called the **stratified realization**, with fundamental poset P itself, constructed as follows. The characteristic function of $\|P\|$ sends a convex combination w of objects of the poset to the minimal object $\min(\text{supp}(w))$ of the support of that convex combination:

$$\|P\| : |P| \rightarrow P \quad , \quad w \mapsto \min(\text{supp}(w)) \in P.$$

The stratum corresponding to the object $p \in P$ is denoted $\text{str}(p) \subset \|P\|$; it consists of all convex combinations w of objects weakly greater than p , whose value at p is nonzero. —

⁶⁰In fact, in the restricted case of finite stratifications, we can always recover a stratification (X, f) from an \mathbb{N} -filtration of X . Define a depth map $\text{depth} : \mathbb{N}(f) \rightarrow \mathbb{N}^{\text{op}}$, mapping $s \in \mathbb{N}(f)$ to k when chains in $\mathbb{N}(f)$ starting at s have maximal length $(k + 1)$. Define the filtration $X_0 \subset X_1 \subset \dots \subset X_{k_{\max}} = X$, where k_{\max} is the maximal depth of elements in $\mathbb{N}(f)$, by setting X_i to be the preimage of $[0, i]$ under the composite $\text{depth} \circ f$.

As we will see later in Construction B.2.14, stratified realization of posets extends to a functor from the category of posets to the category of stratifications.

EXAMPLE B.1.53 (Stratified realizations). We depict three stratified realizations in Figure B.8: from left to right, we have the stratified realizations $\|P\|$ of the ‘1-cell poset’ $P = \{-1 \leftarrow 0 \rightarrow 1\}$, the 2-simplex $P = \{0 \rightarrow 1 \rightarrow 2\}$ and the product of two 1-simplices $P = \{0 \rightarrow 1\} \times \{0 \rightarrow 1\}$. —

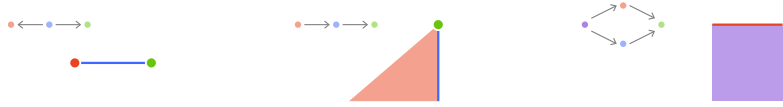

FIGURE B.8. Stratified realizations of posets.

B.2. Stratified maps

OUTLINE. In Section B.2.1, we define stratified maps, coarsenings, refinements, substratifications, and constructible substratifications. In Section B.2.2, we characterize frontier-constructible stratifications, substratifications, and coarsenings in terms of their characteristic and fundamental poset maps. In Section B.2.3, we assemble stratifications into ordinary and enriched categories, and construct the stratified realization and fundamental poset functors. Finally, in Section B.2.4, we introduce stratified bundles and their pullbacks.

B.2.1. Maps, coarsenings, and substratifications.

SYNOPSIS. We define maps of stratifications as continuous maps compatible with the stratification structure, and introduce several important classes of such maps: coarsenings (stratified maps that are homeomorphisms on underlying spaces), refinements (the inverse process to coarsenings), substratifications (stratified inclusions whose strata are connected components of intersections with target strata), and constructible substratifications (substratifications whose strata are exactly strata of the target stratification).

DEFINITION B.2.1 (Map of stratifications). Given stratifications (X, f) and (Y, g) with characteristic maps $f : X \rightarrow \mathbb{N}(f)$ and $g : Y \rightarrow \mathbb{N}(g)$, a **map of stratifications** $F : (X, f) \rightarrow (Y, g)$ is a continuous map $F : X \rightarrow Y$ for which there exists a (necessarily unique) map of posets $\mathbb{N}(F) : \mathbb{N}(f) \rightarrow \mathbb{N}(g)$ such that $\mathbb{N}(F) \circ f = g \circ F$. —

TERMINOLOGY B.2.2 (Stratified maps and stratified homeomorphisms). We frequently refer to maps of stratifications simply as ‘stratified maps’. A ‘stratified homeomorphism’ is a stratified map that has an inverse stratified map; equivalently, it is a stratified map whose underlying continuous map is a homeomorphism and whose induced map on fundamental posets is an isomorphism. —

EXAMPLE B.2.3 (Map of stratifications). In Figure B.9, we depict a stratified map on the left and a non-stratified map on the right. In both cases, the underlying map of topological spaces is given by vertical projection. \square



FIGURE B.9. A stratified map and a non-stratified map.

DEFINITION B.2.4 (Coarsenings and refinements of stratifications). A map of stratifications $F : (X, f) \rightarrow (Y, g)$ is a **coarsening** of (X, f) to (Y, g) , or, synonymously, a **refinement** of (Y, g) by (X, f) , when the underlying map of spaces $F : X \rightarrow Y$ is a homeomorphism. \square

Note that ‘coarsening’ and ‘refinement’ are interchangeable terms, though with opposite variance: a coarsening *coarsens* the domain to the codomain, while a refinement *refines* the codomain to the domain.

EXAMPLE B.2.5 (Coarsening and refinement). In Figure B.10, we depict a coarsening of stratifications of the circle, along with the corresponding refinement indicated by a dashed arrow in the opposite direction. \square

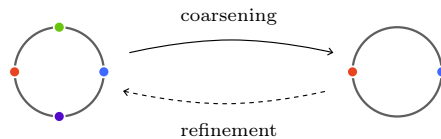

FIGURE B.10. A coarsening and its corresponding refinement of stratifications.

DEFINITION B.2.6 (Substratification). A stratified map $(X, f) \rightarrow (Y, g)$ is a **substratification** if the underlying map $X \subset Y$ is an inclusion and if every stratum s of f is a connected component of $X \cap t$ for some stratum t of g . \square

By extension we refer to a stratified map that is not an inclusion of underlying sets, but whose underlying map is injective and which is a stratified homeomorphism onto a substratification, also as a ‘substratification’.

DEFINITION B.2.7 (Stratification restrictions). Given a stratification (Y, g) and a subspace $X \subset Y$, the **restriction** $(X, g|_X)$ (also simply written (X, g)) is the substratification of (Y, g) whose strata are the connected components of intersections $X \cap t$, for all strata t of g . \square

A stratum of a substratification is allowed to merely include into a stratum of the ambient stratification. Instead, we may also insist that the substratification strata map onto ambient strata, as follows.

DEFINITION B.2.8 (Constructible substratifications). A substratification $(X, f) \rightarrow (Y, g)$ is **constructible** if every stratum of (X, f) is exactly a stratum of (Y, g) . \square

EXAMPLE B.2.9 (Substratifications). In Figure B.11, we depict three stratified maps: the first map is a substratification, which though is not injective on fundamental posets; the second map is a constructible substratification, which thus is injective on fundamental posets; the third map, though injective on underlying spaces, is not a substratification. \square

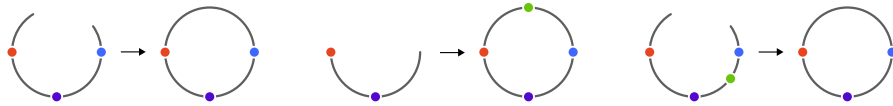

FIGURE B.11. Two substratifications and a non-substratification.

B.2.2. Characterizing stratifications via fundamental maps.

SYNOPSIS. We characterize certain classes and constructions of stratifications in terms of their actions on fundamental posets: frontier-constructible stratifications are those with open characteristic functions, substratifications correspond to discrete fundamental poset maps, and coarsenings of stratifications correspond to connected-quotient maps of fundamental posets.

Recall from Definition B.1.25, a frontier-constructible stratification is a stratification (Y, g) for which the restriction $(\bar{s}, g|_{\bar{s}})$ to the topological closure \bar{s} of any stratum s is a constructible substratification of (Y, g) . Frontier-constructibility has an alternative description in terms of characteristic functions as follows.

LEMMA B.2.10 (Frontier-constructible stratifications are those with open characteristic function). *A stratification (X, f) is frontier-constructible if and only if the characteristic function $f : X \rightarrow \mathbb{N}(f)$ is an open function.*

PROOF. Assume f is frontier-constructible. Let $U \subset X$ be an open subset. We need to show that $f(U) \subset \mathbb{N}(f)$ is open, which in the specialization topology means that $f(U)$ is downward closed. It suffices (because the fundamental poset is generated by formal entrance paths) to check that given an element $s \in f(U)$ and a formal entrance path $r \rightarrow s$, we have $r \in f(U)$. The existence of the formal entrance path $r \rightarrow s$ means $s \cap \partial r \neq \emptyset$; frontier-constructibility then implies that $s \subset \partial r$. As $s \in f(U)$, there is some point of the stratum s that is in U , and because U is open, there must be a point of the stratum r that is in U . Thus $r \in f(U)$ as required.

Conversely, assume $f : X \rightarrow \mathbb{P}(f)$ is open. It suffices to show that if there is a formal entrance path $r \rightarrow s$, i.e. $s \cap \partial r \neq \emptyset$, then $s \subset \partial r$. Suppose there is such an entrance path but by contrast there is a point $p \in s \setminus \partial r = s \setminus \bar{r}$. Then we can choose an open neighborhood $p \in U \subset X$ disjoint from the closure \bar{r} . By assumption it follows that the image $f(U)$ is open, which is to say downward closed; thus $s \in f(U)$ and $r \rightarrow s$ implies that $r \in f(U)$, contradicting the fact that the neighborhood U does not intersect even the closure of r . \square

We can characterize substratifications and coarsenings in terms of fundamental poset maps, as follows.

LEMMA B.2.11 (Substratification from discrete maps). *A map of finite stratifications $F : (X, g) \rightarrow (Y, f)$ is a substratification if and only if $F : X \rightarrow Y$ is a subspace inclusion and $\mathbb{P}(F) : \mathbb{P}(g) \rightarrow \mathbb{P}(f)$ is a discrete map.*

PROOF. Every substratification $F : (X, g) \rightarrow (Y, f)$ is a subspace inclusion on underlying spaces. The fundamental poset map $\mathbb{P}(F)$ is discrete since strata of substratifications are connected components of the intersection of the subspace X with strata of the target stratification f .

Conversely, suppose the stratified map F is a subspace inclusion and that $\mathbb{P}(F)$ is a discrete map. To see that F is a substratification, it suffices to check that the stratification (X, g) is the restricted substratification $(X, f|_X)$ of (Y, f) ; that restriction is obtained by connected component splitting of $f \circ F : X \rightarrow \mathbb{P}(f)$, see Construction B.1.45. Now consider statement (3) of Lemma B.1.46, applied to that composite P -structure $f \circ F : X \rightarrow \mathbb{P}(f)$, using the fact that g is finite and therefore has a continuous characteristic map, and the assumption that $\mathbb{P}(F)$ is discrete; the universality statement implies that g is the characteristic map of the connected component splitting, as required. \square

LEMMA B.2.12 (Coarsenings from connected-quotient maps). *Coarsenings of a finite stratification f (up to isomorphism) are in bijection with connected-quotients of its fundamental poset $\mathbb{P}(f)$ (by sending a coarsening F to its fundamental poset map $\mathbb{P}(F)$).*

PROOF. Let $F : (X, f) \rightarrow (Y, g)$ be a coarsening. The fundamental poset map $\mathbb{P}(F)$ is a connected-quotient map: the space map F is a homeomorphism and strata of (Y, g) are connected, so their preimages are connected and thus point preimages of $\mathbb{P}(F)$ are as well; furthermore, the map $\mathbb{P}(F)$ satisfies condition (2) of Lemma B.1.35 and thus is a quotient.

Conversely, let $H : \mathbb{P}(f) \rightarrow P$ be a connected-quotient map. Define a stratification (X, g) whose strata are the unions of the strata of f in point preimages of H . (Since those point preimages are connected by assumption, the unions are connected and thus define at least a prestratification. By Lemma B.1.40 and Observation B.1.41, the map H is itself the characteristic map of a stratification, and so the composite $X \rightarrow \mathbb{P}(f) \rightarrow P$ is as well.)

The resulting coarsening $(X, f) \rightarrow (X, g)$ is the identity on underlying spaces, and has H as its fundamental poset map as desired. \square

Again, we leave aside analogs of the above results for the case of infinite (and specifically locally finite) stratifications.

B.2.3. Categories of stratifications.

SYNOPSIS. We assemble stratifications and their maps into a category. We construct the stratified realization functor $\|-\|$ from posets to stratifications and the fundamental poset functor \sqcap in the reverse direction. We then promote the fundamental poset functor to an ∞ -functor between $k\mathbf{Top}$ -enriched categories of locally finite stratifications and posets.

NOTATION B.2.13 (The ordinary category of stratifications). Denote by \mathbf{Strat} the category of stratifications and their stratified maps. ---

Posets faithfully embed into stratifications by the stratified realization functor, as follows. (Recall the formulation of stratified realizations $\|P\|$ of posets P from Construction B.1.52.)

CONSTRUCTION B.2.14 (Stratified realization functor). Given a map of posets $F : P \rightarrow Q$, the stratified map $\|F\| : \|P\| \rightarrow \|Q\|$ is given by $w \mapsto \|F\|(w)$, where w is a convex combination of objects of P and $\|F\|(w)$ is the convex combination of objects of Q defined by $\|F\|(w)(q) = \sum_{p \in F^{-1}(q)} w(p)$. This provides the ‘stratified realization functor’

$$\|-\| : \mathbf{Pos} \rightarrow \mathbf{Strat}$$

from the category of posets to the category of stratifications. ---

The fundamental poset construction previously described yields a functor in the opposite direction, from the category of stratifications to the category of posets.

CONSTRUCTION B.2.15 (Fundamental poset functor). Sending a stratification (X, f) to its fundamental poset $\sqcap(f)$, and a map of stratifications $F : (X, f) \rightarrow (Y, g)$ to the map of fundamental posets $\sqcap(F)$, provides the ‘fundamental poset functor’

$$\sqcap : \mathbf{Strat} \rightarrow \mathbf{Pos}$$

from the category of stratifications to the category of posets. ---

OBSERVATION B.2.16 (The fundamental poset left inverts stratified realization). The preceding functors form a section-retraction pair: $\sqcap \|-\| = \text{id}$. ---

We can promote the fundamental poset functor to a functor of ∞ -categories. We would usually model ∞ -categories by \mathbf{Top} -enriched categories (or, in certain contexts, quasicategories). However, for generality and our immediate purposes, we present the following constructions with $k\mathbf{Top}$ -enriched

categories (see Notation B.1.2). Indeed, though we typically care about homotopically well-behaved ‘cell-like’ spaces in \mathbf{Top} , expanding attention to $k\mathbf{Top}$ allows us to include stratified ‘poset-like’ spaces in a single formulation (see Convention B.1.1).

NOTATION B.2.17 (The $k\mathbf{Top}$ -enriched category of stratifications). Denote by Strat the $k\mathbf{Top}$ -enriched category of stratified spaces and their stratified maps; the hom-spaces $\mathit{Strat}((X, f), (Y, g))$ are obtained by topologizing the hom-sets $\mathbf{Strat}((X, f), (Y, g))$ as subspaces of the internal hom $\mathbf{Map}(X, Y)$ in $k\mathbf{Top}$ (see Notation B.1.2). —

Note that restricting the objects to be stratifications of spaces in \mathbf{Top} provides a \mathbf{Top} -enriched category of stratifications.

We next consider the $k\mathbf{Top}$ -enriched category of posets. It will be convenient to restrict attention to locally finite posets (though it is possible to generalize the discussion beyond that case).

NOTATION B.2.18 (The $k\mathbf{Top}$ -enriched category of locally finite posets). Denote by $\mathcal{P}\mathit{os}_{\ell f}$ the $k\mathbf{Top}$ -enriched category of locally finite posets; the hom-spaces $\mathcal{P}\mathit{os}_{\ell f}(P, Q)$ are obtained by endowing the hom-sets $\mathbf{Pos}(P, Q)$ with the topology of the internal homs $\mathbf{Map}(P, Q)$ in $k\mathbf{Top}$. —

REMARK B.2.19 (The case of finite posets). For finite posets P and Q , the space $\mathbf{Map}(P, Q)$ is exactly the hom poset $\mathbf{Pos}(P, Q)$ of poset functors and natural transformations, endowed with its specialization topology. —

CONSTRUCTION B.2.20 (Fundamental poset ∞ -functor). Let $\mathit{Strat}_{\ell f}$ denote the full subcategory of Strat consisting of locally finite stratifications. The fundamental poset functor $\mathbf{Strat} \rightarrow \mathbf{Pos}$ induces an ∞ -functor of $k\mathbf{Top}$ -enriched categories

$$\mathbb{I} : \mathit{Strat}_{\ell f} \rightarrow \mathcal{P}\mathit{os}_{\ell f} \quad .$$

The continuity of that functor on hom-spaces needs verification, which we omit. —

REMARK B.2.21 (Stratified realization ∞ -functor). Counterposed to the preceding construction, one would want to construct a functor $\|-\| : \mathcal{P}\mathit{os}_{\ell f} \rightarrow \mathit{Strat}_{\ell f}$. However, though the realization $\|P\|$ is locally finite when the poset P is locally finite, that association is not continuous on hom-spaces. This failure is symptomatic of a deeper issue: $\mathcal{P}\mathit{os}_{\ell f}$ and Strat naturally would have non-invertible 2-categorical structure, which is ruthlessly inverted when working in the context of topologically enriched categories. —

Finally, we mention a tensoredness property of the ∞ -category of stratifications. For the next two constructions, we assume the underlying spaces of all stratifications are locally compact Hausdorff (to ensure products of compactly generated spaces are still compactly generated, see [Str09, Prop. 2.6]).

CONSTRUCTION B.2.22 (Stratified products). Given two stratifications (X, f) and (Y, g) , the ‘product stratification’ is simply $(X \times Y, f \times g)$ where $f \times g$ is the characteristic function $X \times Y \rightarrow \mathbb{N}(f) \times \mathbb{N}(g)$ obtained by taking the product of characteristic functions $f : X \rightarrow \mathbb{N}(f)$ and $g : Y \rightarrow \mathbb{N}(g)$. Products of stratified maps are obtained by taking products of their underlying continuous maps. Altogether we have the topological product functor

$$(- \times -) : \mathit{Strat} \times \mathit{Strat} \rightarrow \mathit{Strat}. \quad \text{—}$$

Taking products with topological spaces provides a ‘fiberwise **Top**-tensor’ on the ∞ -category of stratified spaces, as follows.

CONSTRUCTION B.2.23 (Fiberwise **Top**-tensoring of $\mathit{Strat}_{\ell f}$). Let (X, f) and (Y, g) be locally finite stratifications and $F : \mathbb{N}(f) \rightarrow \mathbb{N}(g)$ a map between their fundamental posets. Denote by $\mathit{Strat}_{\ell f}(f, g)_F$ the preimage of F under the map $\mathbb{N} : \mathit{Strat}_{\ell f}(f, g) \rightarrow \mathcal{P}\mathit{os}_{\ell f}(\mathbb{N}(f), \mathbb{N}(g))$. By cartesian closedness of **Top**, we may identify $\mathit{Map}(Z, \mathit{Map}(X, Y)) \cong \mathit{Map}(Z \times X, Y)$ (for $Z \in \mathit{Top}$); in particular, we obtain a homeomorphism

$$\mathit{Map}(Z, \mathit{Strat}_{\ell f}(f, g)_F) \cong \mathit{Strat}_{\ell f}(Z \times f, g)_F$$

where the right-hand side denotes the space of stratified maps $Z \times f \rightarrow (Y, g)$ whose underlying map of fundamental posets is F . —

B.2.4. Stratified bundles and pullbacks.

SYNOPSIS. We define stratified bundles as stratified maps that are locally trivial over each stratum of the base. We then introduce pullback stratifications, and briefly mention the notion of constructible bundles.

All spaces in this section are assumed to be locally compact Hausdorff.

DEFINITION B.2.24 (Stratified bundles). A stratified map $p : (X, f) \rightarrow (Y, g)$ is a **stratified bundle** when, for each stratum s of g and each point $x \in s$, there is a neighborhood $U_x \subset s$ inside the stratum s , such that there is a stratification (Z, h) together with a stratified homeomorphism $\tau : U_x \times h \cong (p^{-1}(U_x), f)$ for which $p \circ \tau : U_x \times h \rightarrow U_x$ is the projection. The stratification (Z, h) is called the fiber of p over the stratum s . —

Note that every fiber bundle is a stratified bundle with indiscrete stratifications on both base and total space.

We will usually assume that all the fibers of a stratified bundle are nonempty, in other words that the underlying map of spaces is surjective. In this case, the stratification of the total space determines the stratification of the base space, as follows.

OBSERVATION B.2.25 (The base stratification is determined by the total stratification). Suppose $(X, f) \rightarrow (Y, g)$ and $(X, f) \rightarrow (Y, g')$ are stratified bundles with the same underlying surjective map $F : X \rightarrow Y$. Then the stratifications g and g' are identical. —

Just as fiber bundles can be pulled back along space maps, stratified bundles can be pulled back along stratified maps.

DEFINITION B.2.26 (Pullbacks of stratifications). Given stratifications (X, f) , (Y, g) , and (Z, h) , and maps $F : (X, f) \rightarrow (Z, h)$ and $G : (Y, g) \rightarrow (Z, h)$, the **pullback stratification** $(X, f) \times_{(Z, h)} (Y, g)$ is the stratification $(X \times_Z Y, f \times_h g)$, where $X \times_Z Y$ is the pullback of spaces and $f \times_h g$ is the restriction $f \times g|_{X \times_Z Y}$ of the product stratification $f \times g$ to the pullback space $X \times_Z Y \subset X \times Y$. \square

EXAMPLE B.2.27 (Pullback stratifications). In Figure B.12, we depict a pullback of finite stratifications; note though that the pullback is not finite and does not have continuous characteristic function. \square

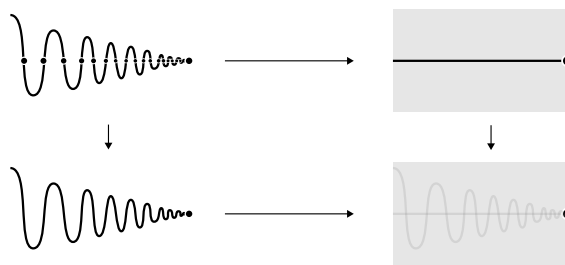

FIGURE B.12. Beware pullbacks of stratifications.

OBSERVATION B.2.28 (Pullbacks of stratified bundles). Given a stratified bundle $p : (X, f) \rightarrow (Y, g)$ and a stratified map $F : (Y', g') \rightarrow (Y, g)$, the pullback map $(X \times_Y Y', f \times_g g') \rightarrow (Y', g')$ is a stratified bundle itself, usually denoted by $F^*p : F^*f \rightarrow g'$. \square

REMARK B.2.29 (Constructible bundles). There is a natural strengthening of the notion of stratified bundles, namely so-called ‘constructible bundles’ [AGV72, Tre09, MS22]. The condition of ‘constructibility’ entails that bundles can be reconstructed from functorial data associated to the fundamental categorical structure of their base stratifications (see also [CP20]). (Here ‘fundamental categorical structure’ may refer, depending on context, to the fundamental poset, fundamental category, fundamental ∞ -category, or another variation thereof.) \square

B.3. Conical and cellulable stratifications

OUTLINE. In Section B.3.1, we define conical stratifications and discuss their relationship to constructibility, frontier-constructibility, and stratified realizations. In Section B.3.2, we construct the fundamental ∞ -category of a conical stratification, discuss its truncations, and show that stratified realizations of posets are 0-truncated. Finally, in Section B.3.3, we define cellulable stratifications, establish that regular cell complexes are conical, discuss cellular links and barycentric subdivision, and sketch a construction of fundamental ∞ -categories for cellulable stratifications.

B.3.1. Conical stratifications.

SYNOPSIS. We define stratified cones, conical stratifications, and topological stratifications. We observe that constructible substratifications inherit conicality while coarsenings need not preserve it, that conical stratifications are frontier-constructible, and that stratified realizations of locally finite posets are conical.

Many stratifications satisfy an additional regularity condition called *conicality*. This condition demands the existence of neighborhoods around strata that look like the product of a cone *normal* to the stratum and an open space *tangential* to the stratum.

TERMINOLOGY B.3.1 (Stratified cones). Given a stratification (X, f) , its **open cone** $\text{cone}(f)$ is the unique stratification of $\text{cone}(X) = X \times (0, 1] \cup_{X \times \{1\}} \top$ containing $f \times (0, 1)$ as a constructible substratification.

Similarly, the **closed cone** $\overline{\text{cone}}(f)$ is the stratification of $\overline{\text{cone}}(X) = X \times [0, 1] \cup_{X \times \{1\}} \top$ containing f (as a stratification of $X \times \{0\}$) as a constructible substratification, and also $\text{cone}(f)$ as a constructible substratification. ---

Note that the poset $\mathbb{P}(\text{cone}(f))$ is $\mathbb{P}(f)^\flat$, i.e. it is obtained from $\mathbb{P}(f)$ by adding a new terminal element \top . The characteristic map $\text{cone}(f) : \text{cone}(X) \rightarrow \mathbb{P}(\text{cone}(f))$ sends the cone point \top to $\top \in \mathbb{P}(f)^\flat$.

DEFINITION B.3.2 (Conical stratification). For a stratification (X, f) , a **tubular neighborhood** of a point $x \in X$ is an open neighborhood U_x of x , together with a stratified space $(Y_x, \text{link}(x))$, a connected topological space Z_x , and a stratified homeomorphism

$$Z_x \times \text{cone}(\text{link}(x)) \cong (U_x, f|_{U_x})$$

sending $z \times \top$ to x , for some $z \in Z_x$. (Here $\top \in \text{cone}(\text{link}(x))$ is the cone point.) The stratification $(Y_x, \text{link}(x))$ is called a ‘link’ at x , and the space Z_x is called both a ‘tangential neighborhood’ of the point x and the ‘cone stratum’ of the tubular neighborhood.

A stratification is **conical** if it has a tubular neighborhood at every point. ---

EXAMPLE B.3.3 (Conical and non-conical stratifications). In Figure B.13, we depict a conical stratification, together with an illustration of a tubular neighborhood decomposing as the product of a cone and a space. In Figure B.14, we depict two other stratifications of the same space, each with just two strata; the first is conical, while the second is not. ---

REMARK B.3.4 (Topological stratifications). A conical stratification in which every stratum is a topological manifold is usually (and confusingly) called a ‘topological stratification’. In this situation, the tangential neighborhoods Z_x can be chosen to be euclidean. The conical stratification shown in Figure B.13 is a topological stratification, but the conical stratification on the left in Figure B.14 is not a topological stratification. ---

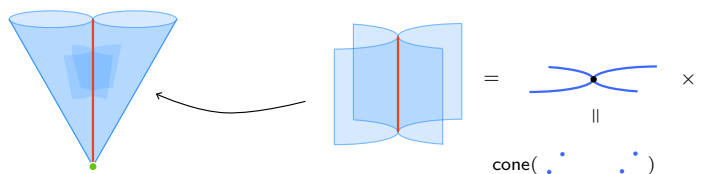

FIGURE B.13. A conical stratification with a tubular neighborhood.

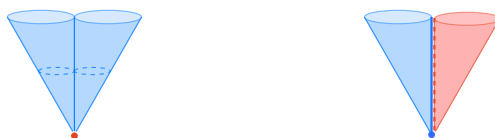

FIGURE B.14. A conical and a non-conical stratification of a cone.

OBSERVATION B.3.5 (Constructible substratifications inherit conicality). If the stratification (X, f) is conical and $(Y, g) \hookrightarrow (X, f)$ is a constructible substratification, then the stratification (Y, g) is also conical. \square

OBSERVATION B.3.6 (Coarsening need not preserve conicality). If the stratification (X, f) is conical and $(X, f) \rightarrow (X, g)$ is a coarsening, then the stratification (X, g) need not be conical. For instance, the second (non-conical) stratification in Figure B.14 is a coarsening of the (conical) stratification in Figure B.13. \square

OBSERVATION B.3.7 (Conical implies frontier-constructible). Every conical stratification is frontier-constructible. In particular, a conical stratification is locally finite if and only if it is pointwise locally finite. Furthermore, conical stratifications have continuous characteristic functions, so a conical stratification is locally finite also if and only if its fundamental poset is locally finite. \square

PROPOSITION B.3.8 (Locally finite stratified realizations are conical). For a locally finite poset P , the stratified realization $\|P\|$ is conical.

PROOF. For any poset element $p \in P$, and any point $x \in \text{str}(p)$ of the corresponding stratum, we construct a tubular neighborhood (which is in fact independent of the choice of x within the stratum). Recall, the points of the stratum $\text{str}(p)$ correspond to convex combinations of objects in $P^{\geq p}$ (with nonzero coefficient for p). The ‘canonical link stratification’ for this stratum, written $\text{link}(p)$, is defined to be $\|P^{< p}\|$. Note that since $P^{\geq p}$ and $P^{< p}$ include into P we may consider convex combinations of objects in $P^{\geq p}$ or $P^{< p}$ as convex combinations of objects in P . The resulting inclusion $\text{str}(p) \hookrightarrow \|P\|$ extends to a tubular neighborhood $\text{str}(p) \times \text{cone}(\text{link}(p)) \hookrightarrow \|P\|$ by mapping (cf. [Lur17, Prop. A.6.8])

$$\text{str}(p) \times \text{link}(p) \times (0, 1] \rightarrow \|P\|$$

$$(w_{\text{str}(p)}, w_{\text{link}(p)}, t) \mapsto w(q) := t \cdot w_{\text{str}(p)}(q) + (1 - t) \cdot w_{\text{link}(p)}(q)$$

The existence of these neighborhoods confirms the conicality of $\|P\|$, as desired. \square

REMARK B.3.9 (Natural non-conical stratifications). One cannot simply decide to only care about conical stratifications, because some fundamental and natural operations produce non-conical stratifications. For instance, though the stratified n -simplex $\|[n]\|$ is conical, by the preceding result, the substratification $\partial\|[n]\|$ determined by the simplex boundary is not conical. —

B.3.2. Fundamental higher categories.

SYNOPSIS. We define the fundamental ∞ -category of a conical stratification as a quasicategory of entrance paths, and describe its $(0, 1)$ - and $(1, 1)$ -truncations as the fundamental poset and fundamental 1-category, respectively. We show that the fundamental ∞ -category of a stratified realization is 0-truncated.

One reason for considering conical stratifications is the availability of a good notion of *entrance path homotopies* between entrance paths, and higher analogs thereof, leading to a definition of fundamental ∞ -category, as follows. While we usually take ∞ -category to mean **Top**-enriched category, in the context of fundamental ∞ -categories of stratifications, we will instead use quasicategories as our model.

DEFINITION B.3.10 (Fundamental ∞ -category, [Lur17, Rmk. A.6.5]). The **fundamental ∞ -category** $\mathbb{P}_\infty(f)$ of a conical stratification (X, f) is the quasicategory whose underlying simplicial set has as m -simplices the maps of the stratified m -simplex $\|[m]\|$ to f ; that is $\mathbb{P}_\infty(f)_m := \text{Strat}(\|[m]\|, f)$. —

Equipped with this notion of fundamental ∞ -category, we may recover the fundamental poset and also a notion of *fundamental 1-category* by a process of categorical truncation.

REMARK B.3.11 (Truncations of categories). Recall, an (n, k) -category, where $0 \leq k \leq n + 1$, is a category that may have non-trivial hom-sets of i -morphisms for $0 \leq i \leq n$ (non-trivial meaning ‘having more than one element’), and any i -morphism with $i > k$ is an equivalence (i.e. has an inverse up to higher equivalences). Common cases include $(1, 1)$ -categories (i.e. ordinary 1-categories), $(\infty, 1)$ -categories (which we also refer to as ∞ -categories), and $(\infty, 0)$ -categories (also known as ∞ -groupoids). But this scheme also has relevant low-dimensional edge cases: $(-1, 0)$ -categories are the booleans, $(0, 0)$ -categories are sets, and $(0, 1)$ -categories are preorders (and thus, up to equivalence of preorders, posets).

We describe the construction of ‘ (n, k) -truncations’ of (m, l) -categories \mathcal{C} in two specific cases. First, if $k = n + 1$, then the $(n, n + 1)$ -truncation $\tau_{n, n+1}\mathcal{C}$ is obtained from \mathcal{C} by replacing any non-trivial hom-set of $(n + 1)$ -morphisms by a one element set. Second, if $k = n$, and $l \leq n$, then the

(n, n) -truncation $\tau_{n,n}\mathcal{C}$ is obtained from \mathcal{C} by replacing $(n + 1)$ -morphisms by strict equalities.⁶¹ —

TERMINOLOGY B.3.12 (0-truncations and 1-truncations). In the context of $(\infty, 1)$ -categories, and when no confusion will arise, we refer to $(0, 1)$ -truncations simply as ‘0-truncations’, and to $(1, 1)$ -truncations simply as ‘1-truncations’ (see [CL20], also for a convenient description of truncation in the framework of quasicategories). —

OBSERVATION B.3.13 (Fundamental poset truncation). For a conical stratification (X, f) , the 0-truncation of the fundamental ∞ -category $\mathbb{P}_\infty(f)$ is the fundamental poset $\mathbb{P}(f)$, i.e. $\tau_{0,1}\mathbb{P}_\infty(f) = \mathbb{P}(f)$. —

CONSTRUCTION B.3.14 (Fundamental 1-categories). The **fundamental 1-category** $\mathbb{P}_1(f)$ of a conical stratification (X, f) is the 1-truncation $\tau_{1,1}\mathbb{P}_\infty(f)$ of the fundamental ∞ -category $\mathbb{P}_\infty(f)$. —

A direct definition of the fundamental 1-category, not using the fundamental ∞ -category or categorical truncation, would instead proceed using path components of the space of entrance paths (see [Woo09]).

REMARK B.3.15 (The fundamental ∞ -categories of stratifications). The class of ∞ -categories that are (up to equivalence) obtained as the fundamental ∞ -categories of conical stratifications can be characterized as the ∞ -categories with a conservative functor to a poset (see [BGH18, §2.1], also [Hai24]). Thus, such ∞ -categories could reasonably be called ‘ ∞ -posets’: ∞ -posets are to posets, what ∞ -groupoids are to sets, and what ∞ -categories are to categories.⁶² (In each of those three cases the ∞ -notion is characterized as having a conservative truncation to the ordinary notion.) —

As above, an ∞ -category is 0-truncated if its hom-spaces are (-1) -types, i.e. they are either empty or contractible. We may now consider the 0-truncatedness of the fundamental ∞ -categories of stratified realizations of posets.

LEMMA B.3.16 (Fundamental ∞ -categories of stratified realizations). *Given a locally finite poset P , the fundamental ∞ -category of its stratified realization $\|P\|$ is equivalent to (the nerve of) P , that is,*

$$\mathbb{P}_\infty \|P\| \simeq NP.$$

In particular, $\mathbb{P}_\infty \|P\|$ is 0-truncated.

PROOF. We first check that $\mathcal{C} \equiv \mathbb{P}_\infty \|P\|$ is 0-truncated. It suffices [CL20, Prop. 3.12] to show that any sphere $\phi : \partial[m] \rightarrow \mathcal{C}$, for $m > 1$, has a filler (note, here we think of $[m]$ as a simplicial set, which is sometimes denoted $\Delta[m]$ in the literature). By the definition of \mathbb{P}_∞ , such a map ϕ is

⁶¹More generally, and informally, an (n, k) -truncation, $k < n$, retains only the equivalences as i -morphisms for $i > k$, and replaces $(n + 1)$ -equivalences by strict equalities.

⁶²Perhaps we discover that ∞ -groupoids should have been called ‘ ∞ -sets’.

represented by a continuous map $|\phi| : |\partial[m]| \rightarrow |P|$. Pick $x \in P$ such that $|\phi|(0) \in \text{str}(x)$. Then $\text{im}|\phi|$ lies in the closure of $\text{str}(x)$, i.e. in $|P^{\geq x}| \subset |P|$. Note that $|P^{\geq x}| = \text{cone}|P^{>x}|$. Similarly, identify $|[m]| \cong \text{cone}(|\partial[m]|) = (|\partial[m]| \times [0, 1]) /_{|\partial[m]| \times \{0\}}$. Then define the filler $\psi : |[m]| \rightarrow |P^{\geq x}|$ by mapping $(q, t) \mapsto (|\phi|(q), t)$. By construction, ψ sends the interior of $|[m]|$ to the stratum $\text{str}(x)$ and thus is a stratified map, as needed.

Since \mathcal{C} is 0-truncated, it is equivalent to $N(\text{ho}(\mathcal{C}))$ [CL20, Prop. 3.8]. Furthermore, the homotopy category of any 0-truncated ∞ -category has a skeleton that is a poset [CL20, Prop. 3.10]. Let Q denote a posetal skeleton of $\text{ho}(\mathcal{C})$. Observe that the map $Q \rightarrow P$ sending q to x iff $q \in \text{str}(x)$ is an isomorphism. We thus obtain an equivalence

$$\mathbb{P}_\infty \|P\| \equiv \mathcal{C} \simeq N(\text{ho}(\mathcal{C})) \simeq NQ \cong NP,$$

as desired. Altogether this composite sends a 0-simplex of the fundamental ∞ -category, that is a point of the stratified realization, to the 0-simplex of the nerve of the poset, i.e. the element of the poset, representing the stratum containing the given point. \square

TERMINOLOGY B.3.17 (0-truncated stratifications). A conical stratification (X, f) is called ‘0-truncated’ if its fundamental ∞ -category $\mathbb{P}_\infty(f)$ is 0-truncated. —

In particular, the preceding lemma shows that stratified realizations of posets are 0-truncated.

REMARK B.3.18 (0-Truncatedness of sets and posets). As mentioned earlier, sets are to (sufficiently nice) spaces what posets are to (sufficiently nice) stratifications. The previous lemma provides one more aspect to that analogy: geometric realizations of sets (considered as $(0, 0)$ -categories) are spaces whose fundamental ∞ -groupoids are 0-truncated; similarly, stratified realizations of posets (considered as $(0, 1)$ -categories) are stratified spaces whose fundamental ∞ -categories are 0-truncated. —

REMARK B.3.19 (The higher category of stratifications). Since stratifications have fundamental $(\infty, 1)$ -categories, the category of stratifications should really be considered an $(\infty, 2)$ -category. That comment can be further sharpened, as follows. We have seen that the fundamental ∞ -category of a stratification is an $(\infty, 1)$ -poset (i.e. an (∞, ∞) -category whose truncation functor to its homotopy poset is conservative). Therefore, the category of stratifications can be considered, more precisely, an $(\infty, 2)$ -poset (i.e. an (∞, ∞) -category whose truncation functor to its homotopy 2-poset is conservative; here a 2-poset is a poset-enriched category, i.e. a $(1, 2)$ -category). This situation can again be analogized to the more familiar context of spaces: the fundamental ∞ -category of a space is an $(\infty, 0)$ -category (i.e. an (∞, ∞) -category whose truncation functor to its homotopy set is conservative); thus the category of spaces is an $(\infty, 1)$ -category (i.e. an (∞, ∞) -category whose truncation functor to its homotopy 1-category is conservative). —

B.3.3. Cellulable stratifications.

SYNOPSIS. We define cellular stratifications as constructible substratifications of regular cell complexes, and cellulable stratifications as coarsenings of cellular stratifications. We show that regular cell complexes are conical, discuss cellular links and stars, mention the cellular barycentric subdivision, and sketch the construction of fundamental ∞ -categories for cellulable stratifications.

Though conical stratifications provide a well-established niceness condition, they are not sufficiently general for our purposes: conicality is not preserved under coarsening or other simple operations such as restriction to boundaries. We therefore introduce the notion of *cellulable stratifications*, which provides a more flexible alternative context. These stratifications are obtained from regular cell complexes by taking constructible substratifications and coarsenings. There is a natural construction of the fundamental ∞ -category of a cellulable stratification, exploiting the 0-truncatedness of regular cell complexes, rather than the tubular neighborhood structure of conical stratifications.

Recall, a regular cell complex is a locally finite, frontier-constructible stratification in which strata are open disks (called the ‘open cells’) whose closures are closed disks (called the ‘closed cells’).

DEFINITION B.3.20 (Cellular stratifications). A stratification (Y, g) is **cellular** when it is a constructible substratification $(Y, g) \hookrightarrow Z$ of a regular cell complex Z (implicitly stratified by its cells). —

DEFINITION B.3.21 (Cellulable stratifications). A stratification is **cellulable** when it is a coarsening of a cellular stratification. —

TERMINOLOGY B.3.22 (Cellulations). A ‘cellulation’ of a cellulable stratification (X, f) is a choice of refinement $(Y, g) \rightarrow (X, f)$ by a cellular stratification (Y, g) . —

Since constructible substratifications and coarsenings commute (i.e. any coarsening of a constructible substratification is a constructible substratification of a coarsening), the class of cellulable stratification can alternatively be described as follows.

OBSERVATION B.3.23 (The class of cellulable stratifications). The class of cellulable stratifications is the smallest class of stratifications containing regular cell complexes, and satisfying the following two closure properties:

- (1) If $(Y, g) \rightarrow (X, f)$ is a coarsening and (Y, g) is cellulable, then (X, f) is cellulable.
- (2) If $(Y, g) \subset (X, f)$ is a constructible substratification and (X, f) is cellulable, then (Y, g) is cellulable. —

REMARK B.3.24 (Local finiteness assumption). Unless otherwise stated, we assume our cellulable stratifications are locally finite. In fact, the latter

condition automatically holds for any cellulable stratification that is frontier-constructible: indeed, cellular stratifications are pointwise locally finite, coarsenings preserve that property, and for frontier-constructible stratifications, pointwise local finiteness implies local finiteness ([Observation B.1.26](#)). \square

We now consider the conicality of regular cell complexes, cellular stratifications, and cellulable stratifications. Note that the stratification of a general (non-regular) cell complex need not be conical, even when the complex is finite (i.e. has only finitely many cells). By contrast, regular complexes are conical, as follows.

PROPOSITION B.3.25 (Regularity implies conicality). *Regular cell complexes are conically stratified.*

PROOF. For a regular cell complex X , there is a stratified homeomorphism $X \cong \|\mathbb{N}X\|$ of the complex with the stratified realization of its fundamental poset (see [[Bjö84](#), §3]). From [Proposition B.3.8](#), it follows that regular cell complexes are conically stratified. \square

OBSERVATION B.3.26 (Cellular stratifications are conical). A cellular stratification is by definition a constructible substratification of a regular cell complex; combining [Proposition B.3.25](#) and [Observation B.3.5](#) then shows that cellular stratifications are conical. \square

OBSERVATION B.3.27 (Cellulable stratifications need not be conical). Because of [Observation B.3.6](#), cellulable stratifications (even if locally finite) need not be conical. Thus the previous construction of fundamental ∞ -categories, from [Definition B.3.10](#), does not apply to cellulable stratifications. We will therefore need to take a different approach to defining fundamental ∞ -categories in this context. \square

TERMINOLOGY B.3.28 (Cellular links and cellular stars). Since a regular cell complex X is conical, each cell $x \in X$ has a canonical link stratification; that link is called the ‘cellular link’ and denoted simply $\text{link}(x)$. The cellular link may be combinatorially constructed as the stratified realization of the poset $(\mathbb{N}X)^{<x}$ (see the proof of [Proposition B.3.8](#)).

Each cell $x \in X$ also has a (closed) ‘cellular star’, denoted $\text{star}(x)$, constructed as follows. As a subspace $\text{star}(x) \subset X$ is the simplicial star of the vertex x in the complex $N\mathbb{N}X$; the star is stratified such that its interior and its boundary are each separately substratifications of the star and substratifications of the complex X . Note that there are stratified maps from the closed star into the complex, $\text{star}(x) \hookrightarrow X$, and from the closed cell into the closed star, $\bar{x} \hookrightarrow \text{star}(x)$. Removing the boundary of the closed star produces the ‘open cellular star’. That open star contains the open cell x as a stratum; we refer to that stratum as the ‘core cell’ of the star. See [Figure B.15](#) for an illustration of a cell x , its link (circled), and its stratified cellular star (colored). \square

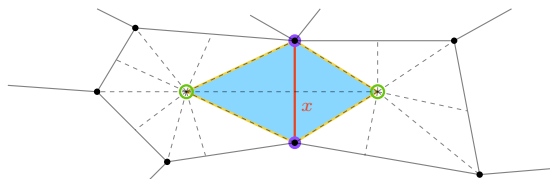

FIGURE B.15. The link (circled) and stratified cellular star (colored) of a cell x in a regular cell complex.

REMARK B.3.29 (Pathological strata in links and stars). The closures of strata of the cellular link are the geometric realizations of half-open interval posets $[y, x) := (\mathbb{P}X)^{\geq y, < x}$; the strata themselves are the complements in those realizations of the realizations of the open interval posets (y, x) . Open intervals (y, x) in cellular posets realize to homology spheres [Bjö84] (and in fact homotopy spheres if x is a 0-cell, cf. [Mau96, Prop. 3.4.3]), and so the strata of the cellular link are open cones of homology spheres. In particular, the strata of the cellular link need not be cells.

Furthermore, the closures of strata in the boundary of the cellular star (not in the boundary of the closed core) are typically higher suspensions of the closures of strata in the cellular link. Similarly, the closures of strata in the open cellular star (excepting the core stratum) are higher suspensions of the closures of strata in the cone of the cellular link—the double suspension theorem [Can79, Edw80, Edw06] ensures (when the core cell is not 0-dimensional) that these closed strata are in fact topological closed cells.

The failure of closed strata in the cellular link to be cells, in general, can be considered pathological. It follows from the fact that links in triangulated manifolds need not be spheres, but are merely homology spheres; indeed, the realization of the open interval $(y, x) \subset \mathbb{P}X$ is a link in the triangulated sphere $|(\mathbb{P}X)^{> y}|$, cf. [FP90, Bjö84]. The fact that the double suspension theorem papers over these homology spheres (at least in the cellular stars) is little comfort, relying as it does on wild, infinitary constructions. The real remedy is to restrict attention to regular piecewise linear cell complexes, i.e. stratified realizations of piecewise linear cellular posets, in which the cellular links are again regular cell complexes. —

REMARK B.3.30 (Cellular links are stratified links). From Observation B.3.26, we know that cellular stratifications are conical, and therefore have tubular neighborhoods, (stratified) links, and tangential neighborhoods in the sense of Definition B.3.2. Note that, for cellular stratifications, the open cellular stars, cellular links, and core cells described in Terminology B.3.28 provide concrete instances of tubular neighborhoods, links, and tangential neighborhoods. —

OBSERVATION B.3.31 (Cellular stratifications are 0-truncated). Regular cell complexes are stratified realizations of locally finite posets. Thus by Lemma B.3.16, for a regular cell complex X , there is an equivalence

$\mathbb{P}_\infty(X) \simeq N\mathbb{P}(X)$ (taking the 0-simplex at a point to the 0-simplex determined by the stratum containing that point). There is similarly an equivalence $\mathbb{P}_\infty(f) \simeq N\mathbb{P}(f)$ for a cellular stratification (Y, f) , by restriction from the equivalence for the regular cell complex (that has (Y, f) as a constructible substratification). \square

When working with cellular stratifications, a useful tool is barycentric subdivision; we describe such subdivisions from the point of view of cellular posets, as follows.

CONSTRUCTION B.3.32 (Conical subdivision and barycentric subdivision). Let X be a combinatorial regular cell complex represented by a cellular poset. For $x \in X$ being a cell in X , the ‘conical subdivision’ $\mathbf{CSub}_X(x)$ of x in X is the cellular poset obtained by the pushout

$$\begin{array}{ccc} X^{>x} & \hookrightarrow & (X^{>x})^\triangleright \\ \text{id} \times \{0\} \downarrow & & \downarrow \\ X^{>x} \times [1] & \longrightarrow & \mathbf{CSub}_X(x) \end{array}$$

Note that the ‘boundary’ $X^{>x} \times \{1\}$ of the subdivision $\mathbf{CSub}_X(x)$ is canonically isomorphic to the original boundary $X^{>x}$ of the cell x . Thus we can glue the subdivision onto the complement $X \setminus x$, effectively replacing the poset element x by the ‘interior’ subposet $(X^{>x})^\triangleright$, or equivalently, in cellular terms, replacing the closure of the cell x by the closed subdivided cell $\mathbf{CSub}_X(x)$ (see Figure B.16).

The cellular ‘barycentric subdivision’ $\mathbf{BSub}(X)$ (cf. [War96]) is obtained by, inductively in increasing cell dimensions, replacing all cells $x \in X$ by their conical subdivisions. In that inductive process, let $X_{(0)} = X$ and let $X_{(i)}$ be formed from $X_{(i-1)}$ by replacing all i -cells with their conical subdivisions. There is a natural map of posets $\mathbf{BSub}(X) \rightarrow X$ from the barycentric subdivision to the original poset, namely the composite

$$\mathbf{BSub}(X) = X_{(N)} \rightarrow X_{(N-1)} \rightarrow \cdots \rightarrow X_{(2)} \rightarrow X_{(1)} \rightarrow X_{(0)} = X$$

where N is the maximal cell dimension in X , and the map $X_{(i)} \rightarrow X_{(i-1)}$ sends, for each cell $x \in X_{(i-1)}$, the interior subposet $(X^{>x})^\triangleright$ to the element x (and the map is the identity elsewhere). \square

OBSERVATION B.3.33 (Barycentric subdivisions are subdivisions). For a cellular poset X , there is a stratified coarsening $\|\mathbf{BSub}(X)\| \rightarrow \|X\|$ of stratified realizations, unique up to homotopy, whose fundamental poset mapping is the barycentric subdivision map $\mathbf{BSub}(X) \rightarrow X$. \square

One advantage of working with cellulable stratifications (as opposed to conical stratifications) is that we may exploit the 0-truncatedness of regular

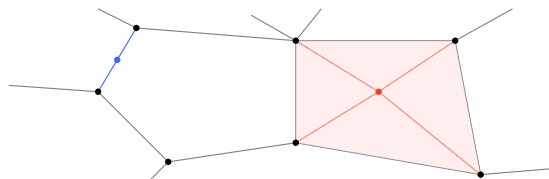

FIGURE B.16. The conical subdivision of a 1-cell (blue) and a 2-cell (red) in a regular cell complex.

cell complexes. In particular, we can define fundamental ∞ -categories of cellulable stratifications by presenting them as *homotopical posets*, as follows.⁶³

CONSTRUCTION B.3.34 (The fundamental ∞ -category for cellulable stratifications). Let (X, f) be a cellulable stratification. Pick a cellular stratification (Y, g) refining (X, f) , and denote by $F : \mathbb{P}(g) \rightarrow \mathbb{P}(f)$ the fundamental poset map of that refinement. Let $W_F = \{\alpha \mid F(\alpha) = \text{id}\}$ denote the set of morphisms in the fundamental poset $\mathbb{P}(g)$ that map to identities under the coarsening. (These are morphisms represented by entrance paths in the refinement that are invertible paths in the original cellulable stratification.) The pair $(\mathbb{P}(g), W_F)$ is a homotopical category in the sense of [DHKS04] (see also [Rie14, Defn. 2.1.1]). The **fundamental ∞ -category** $\mathbb{P}_\infty(f)$ of the cellulable stratification f is the ∞ -category presented by the homotopical poset $(\mathbb{P}(g), W_F)$.⁶⁴ —

REMARK B.3.35 (Well-definition of the fundamental ∞ -category). Given a cellulable stratification (X, f) , the preceding construction of the fundamental ∞ -category $\mathbb{P}_\infty(f)$ involved a choice of cellular refinement (Y, g) of the stratification (X, f) . Establishing the irrelevance of that choice is, in general, a substantive matter. However, in the case of suitable conical cellulable stratifications, it suffices to establish an equivalence between the homotopical poset $(\mathbb{P}(g), W_F)$ and the quasicategory given in Definition B.3.10. —

EXAMPLE B.3.36 (Fundamental categories of stratified circles). In Figure B.17, we depict two stratifications f_1 and f_2 of the circle, together with a mutual cellular refinement (in the middle), and the resulting fundamental ∞ -categories $\mathbb{P}_\infty(f_1)$ and $\mathbb{P}_\infty(f_2)$ presented as homotopical posets. Of course the first stratification is trivial and so the given fundamental ∞ -category is a presentation of the fundamental ∞ -groupoid of the circle, while the second stratification is nontrivial, as evidenced and remembered by the non-invertible morphisms in its fundamental ∞ -category. —

⁶³A *homotopical category* in the sense of [DHKS04] is a category equipped with a class of weak equivalences containing all identities and satisfying the two-out-of-six property; see also [Rie14, §2.1]. Simplicial localization [DK80a, DK80b] is most directly suited to such data. A homotopical poset is a homotopical category whose underlying category is a poset.

⁶⁴One could obtain an explicit quasicategory by, for instance, taking the homotopy coherent nerve of the simplicial localization at the weak equivalences [DK80a, DK80b].

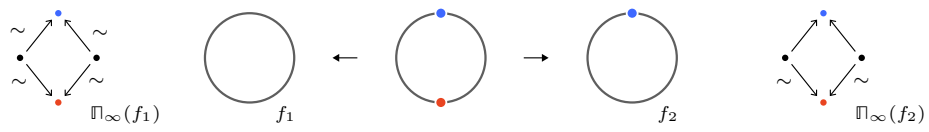

FIGURE B.17. Fundamental categories of two stratified circles.

APPENDIX C

A menagerie of framed regular cells

This appendix illustrates an assemblage of low-dimensional framed regular cells and their corresponding combinatorial representations as n -truss blocks. That combinatorial classification was the primary content of [Chapter 3](#), and the correspondence is informally visible in the pictures: the total poset of the truss block is the fundamental poset of the regular cell, and successively projecting out the highest frame direction yields a tower of lower-dimensional cells and their associated fundamental posets.

C.1. 2-dimensional cells

There is a unique framed regular 1-dimensional cell, namely the closed framed interval. Already in dimension 2 there are infinitely many framed regular cells; necessarily they all project to the framed interval. In [Figure C.1](#) we illustrate a few of the simplest framed regular 2-cells; the framing is induced by realizing the cells in \mathbb{R}^2 , and that realization is indicated by the axes in the lower left corner of the figure. The first three cells are familiar shapes, namely the 2-globe, the 2-simplex, and the 2-cube; we refer to the subsequent three 2-cells as the V-cell, the Y-cell, and the X-cell, as they are dual to a V-shaped singularity, a Y-shaped singularity, and an X-shaped singularity, respectively.

C.2. 3-dimensional cells

We next consider framed regular cells in dimension 3. We organize these cells, primarily, by which framed regular 2-cell they project to, and, secondarily, by the cardinality of the total poset of their fundamental truss block.

In [Figure C.2](#) we depict a few of the simplest framed regular 3-cells that project to the 2-globe.

- › The first four cells are the 3-globe, the suspended 2-simplex, the suspended 2-cube, and the suspended Y-cell.
- › The sixth cell is a product of a 2-globe c_2 and a 1-globe c_1 ; here the product is the usual stratified product (see [Construction B.2.22](#)), with framing induced by the product $c_2 \times c_1 \hookrightarrow \mathbb{R}^2 \times \mathbb{R}^1$ of the given realizations $c_2 \hookrightarrow \mathbb{R}^2$ and $c_1 \hookrightarrow \mathbb{R}^1$.
- › The fifth cell is a degeneration of that product, collapsing one of the fiber 1-cells to a point.

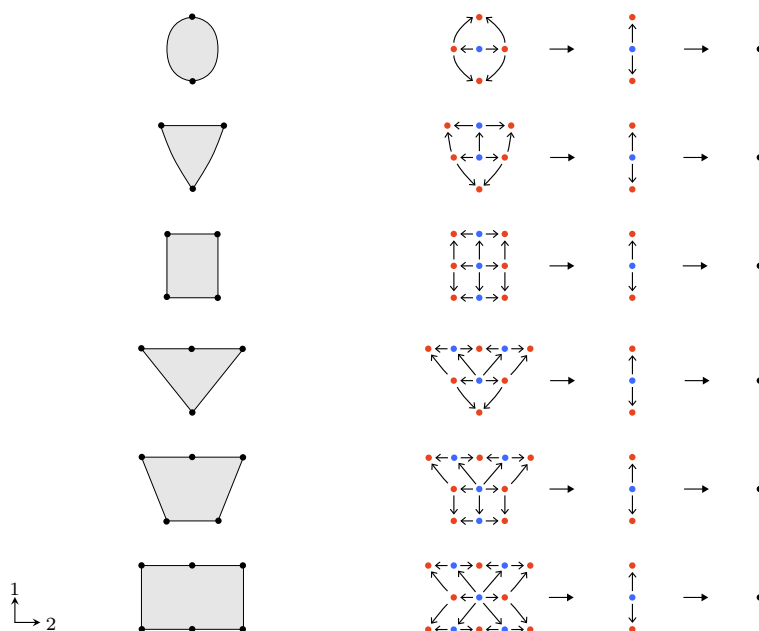

FIGURE C.1. The simplest 2-cells.

- > The last cell already exhibits a more complicated structure, where a central Y-cell collapses to a point on one side, and degenerates asymmetrically to an interval on the other side.

In Figure C.3 we similarly depict framed regular 3-cells that project to the 2-simplex.

- > The first such cell is a ‘triangoli cell’, that is a pillowed 2-simplex having two 2-simplices (glued along their boundaries) as its boundary.
- > The second cell is the cone of the 2-globe c_2 ; here the cone is the usual stratified closed cone (see Terminology B.3.1), with framing derived by extending the given realization $c_2 \hookrightarrow \mathbb{R}^2$ to a realization $\text{cone}(c_2) \hookrightarrow \mathbb{R} \times \mathbb{R}^2$.
- > The third and fourth cells both involve a central 2-simplex partially degenerating, to an interval or a 2-globe, on one side; the fifth cell has a 2-cube similarly degenerating to an interval.
- > The last two cells both contain a V-cell slice, but along different axes.

Altogether, of course, the more elaborate framed 3-cells begin to defy concise description.

In Figure C.4 we depict further 3-cells that project to the 2-simplex. These 3-cells have a somewhat different character than all the previous 3-cells, in that they admit piecewise linear realizations.

- > The first two cells are both 3-simplices, but with distinct framed structures.

- › The third and fourth cells are both square pyramids, but again with distinct framed structures.
- › The last cell is of course a framed product of a 2-simplex and a 1-simplex.

In [Figure C.5](#) we depict framed regular 3-cells that project to the 2-cube.

- › The first such cell is a ‘ravioli cell’, that is a pillowed 2-cube having two 2-cubes (glued along their boundaries) as its boundary.
- › The second and third cells burst open an edge or two of the ravioli cell into a 2-globe.
- › The fourth cell is a product of a 1-globe c_1 and a 2-globe c_2 . We see that the product of framed cells is not commutative: this cell $c_1 \times c_2$ is not framed equivalent to the product $c_2 \times c_1$ shown in [Figure C.2](#).
- › The fifth cell is another, framed distinct from the previous ones, square pyramid.
- › The sixth cell is another product, of a 1-simplex and a 2-simplex, distinct from the product of the 2-simplex and 1-simplex in the previous figure.
- › The last cell is of course the standard framed 3-cube, itself a triple product.

Finally, in [Figure C.6](#), we depict a selection of more complicated 3-cells. To give a deeper understanding of the geometry of these cells, we also now illustrate their dual open meshes. (The framed cell corresponds to the given closed 3-truss, which dualizes to an open 3-truss, which in turn corresponds, by the main equivalence of [Chapter 4](#), to an open 3-mesh.)

- › The first 3-cell projects to the 2-dimensional V-cell; we sometimes refer to this 3-cell as the 3-dimensional ‘quadratic cell’ because the dual mesh exhibits a quadratic 1-tangle singularity. Note that this cell is the first one in our menagerie that has a boundary slice (in this case the top 2-3-planar slice) that is not in fact a topological cell. Though at first perhaps distressing, that behavior of the boundary slice is still completely combinatorially controlled by the classifying truss block.
- › The second 3-cell projects to the 2-dimensional X-cell; we might refer to this 3-cell as a ‘braid cell’, since its dual mesh exhibits half of a 1-tangle braid, as illustrated.
- › The third and last 3-cell projects to the 2-globe, and has an X-cell as its 2-3-planar central slice; we refer to it fancifully as the ‘treccioni’ cell.

C.3. 4-dimensional cells

Though we are reaching the limits of concise visualizability on paper, we also illustrate several framed regular 4-cells. In [Figure C.7](#) we depict the simplest framed regular 4-cell, namely the 4-globe. The green arrow of the 4-frame indicates a fourth dimension (in first coordinate position), corresponding to the direction of the 1-frame vector. In [Figures C.8](#), [C.9](#), and [C.10](#) we similarly depict, respectively, the double cone of the 2-globe, the product of the 2-simplex and the 2-globe, and the (framed distinct) product

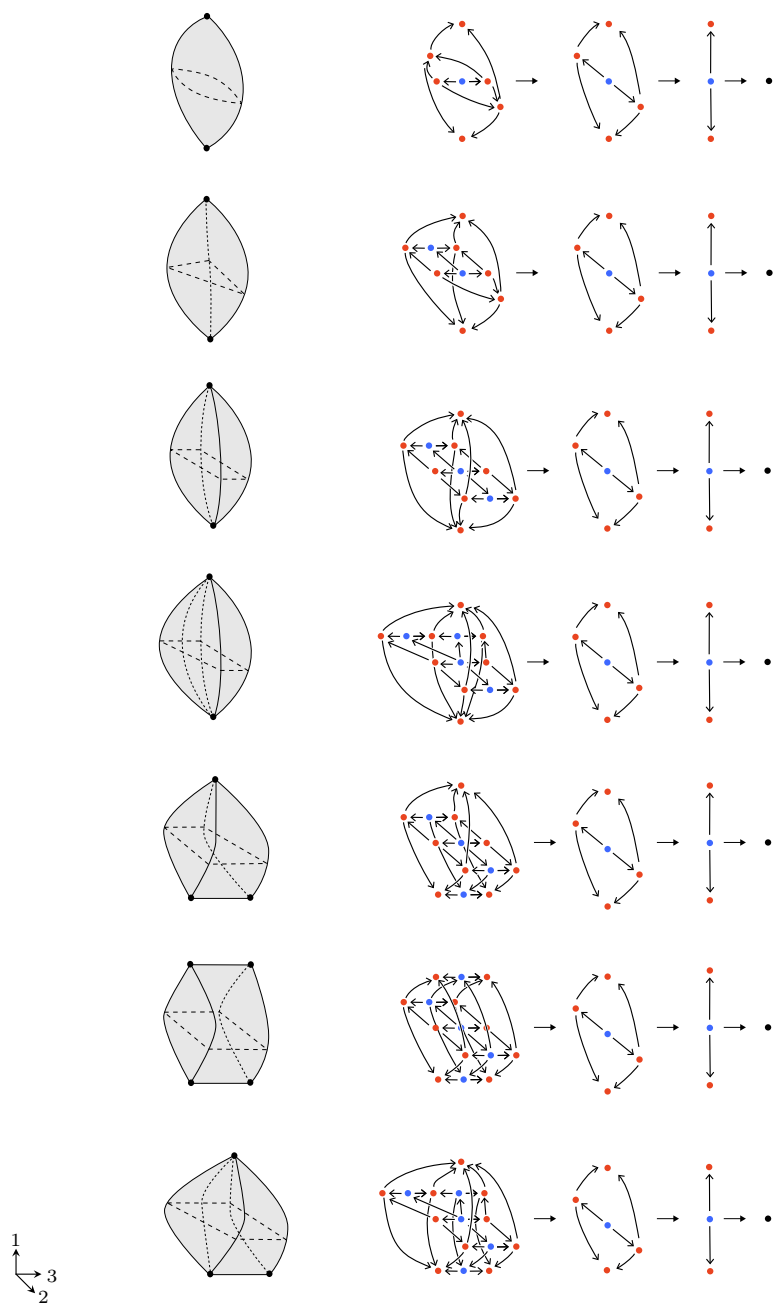

FIGURE C.2. The simplest 3-cells projecting to the 2-globe.

of the 2-globe and 2-simplex. Finally, in Figure C.11 we illustrate a more complex 4-cell, interpolating from a quadratic 3-cell, through a burst ravioli, to a (circa-2002) reverse astropop.

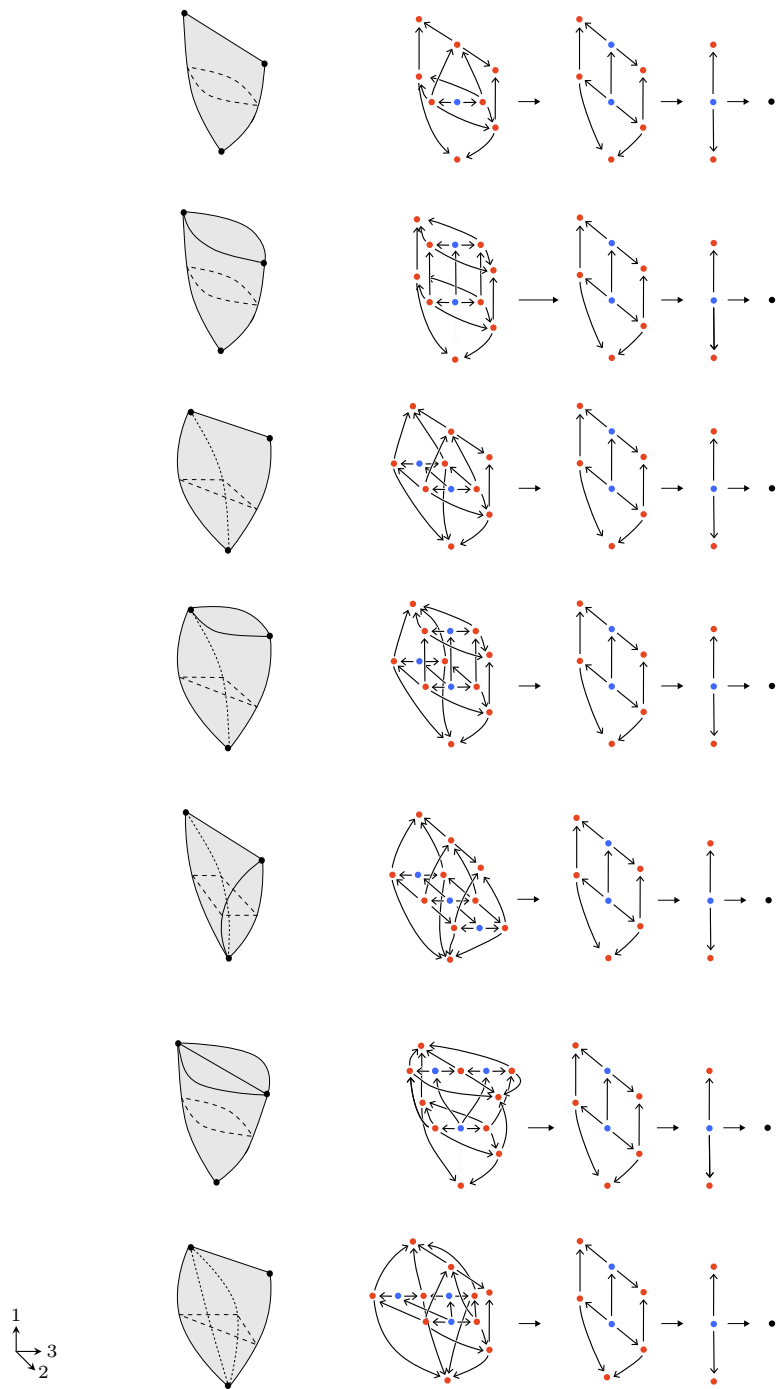

FIGURE C.3. The simplest 3-cells projecting to the 2-simplex.

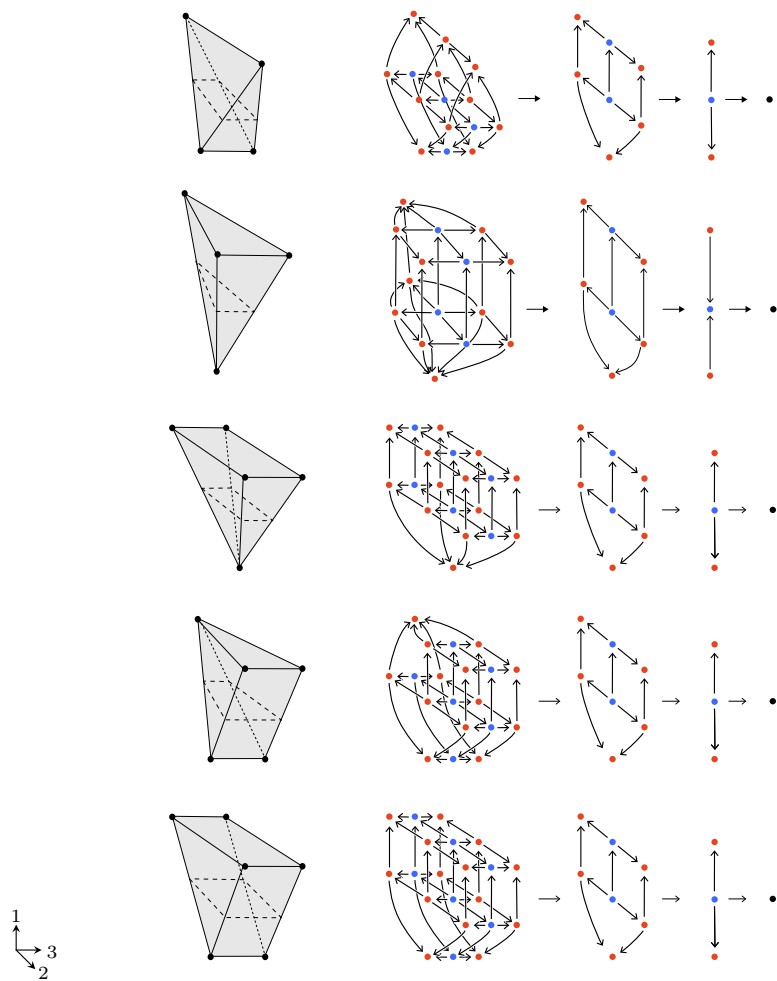

FIGURE C.4. Further 3-cells projecting to the 2-simplex.

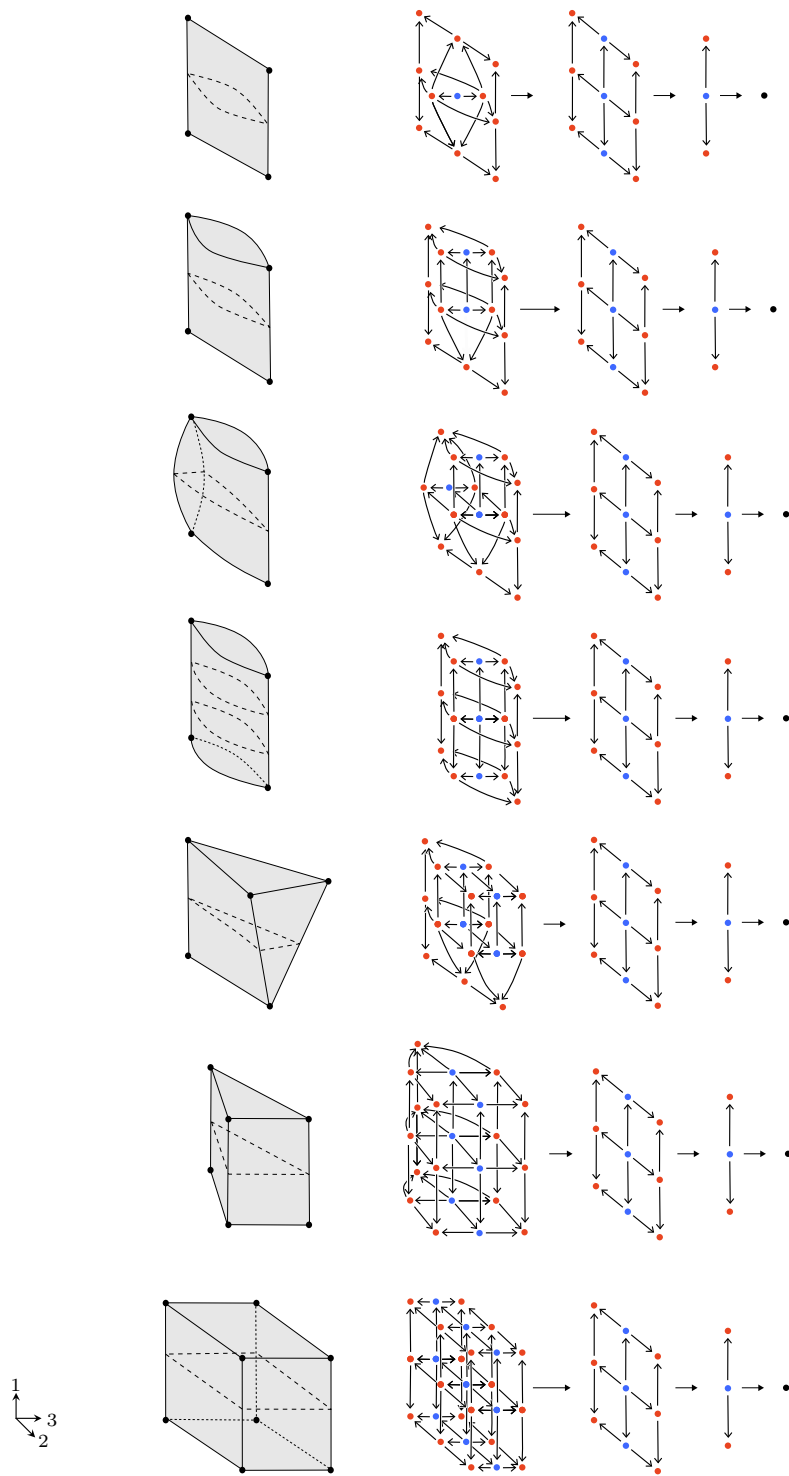

FIGURE C.5. The simplest 3-cells projecting to the 2-cube.

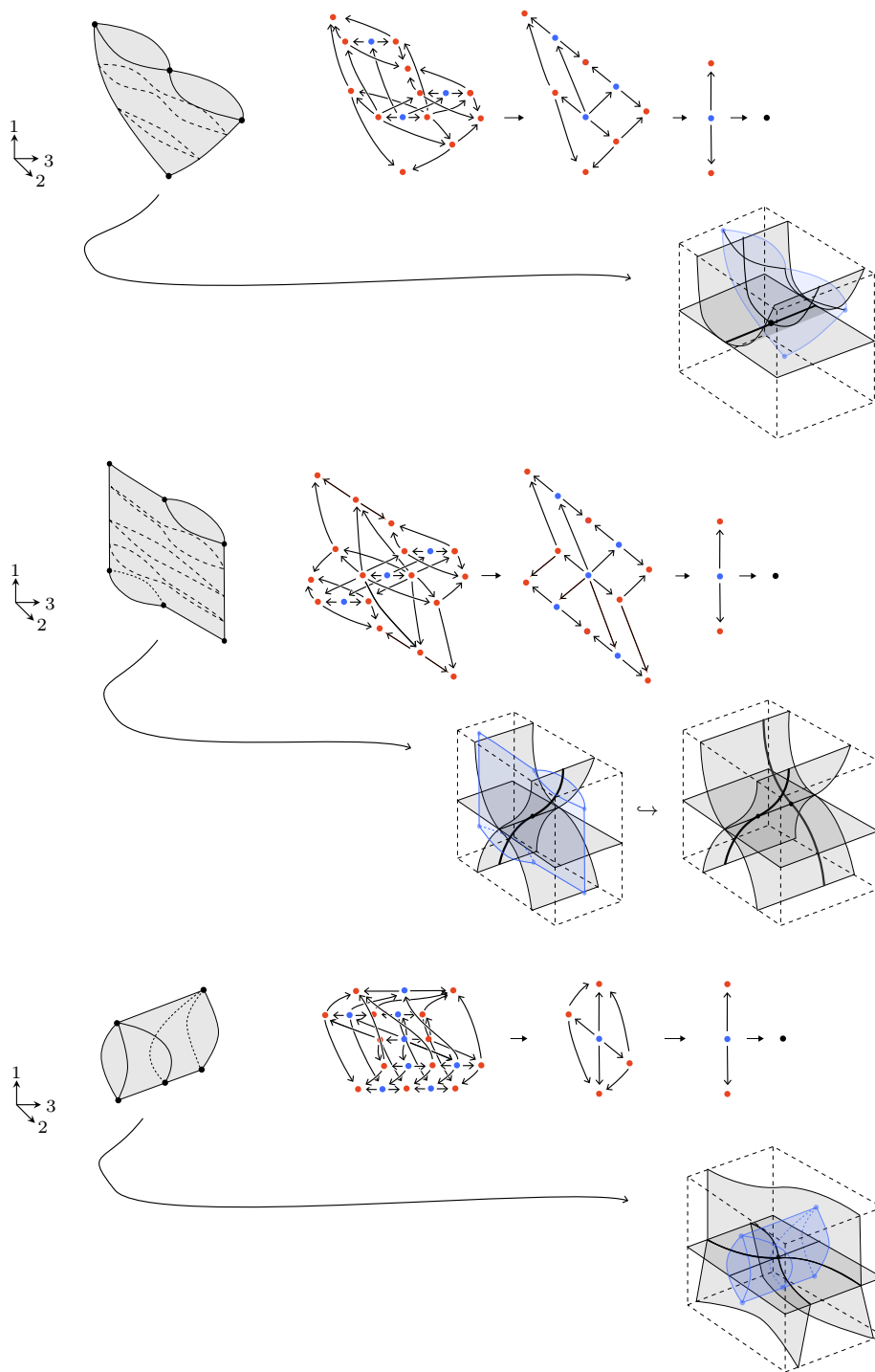

FIGURE C.6. More exotic 3-cells and their dual open meshes.

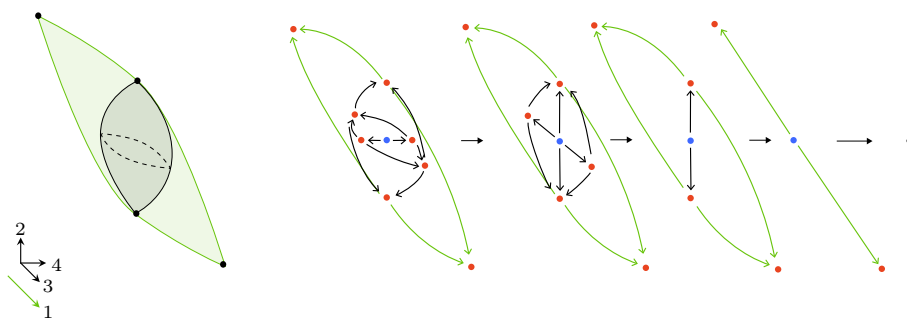

FIGURE C.7. The 4-globe as a 4-cell.

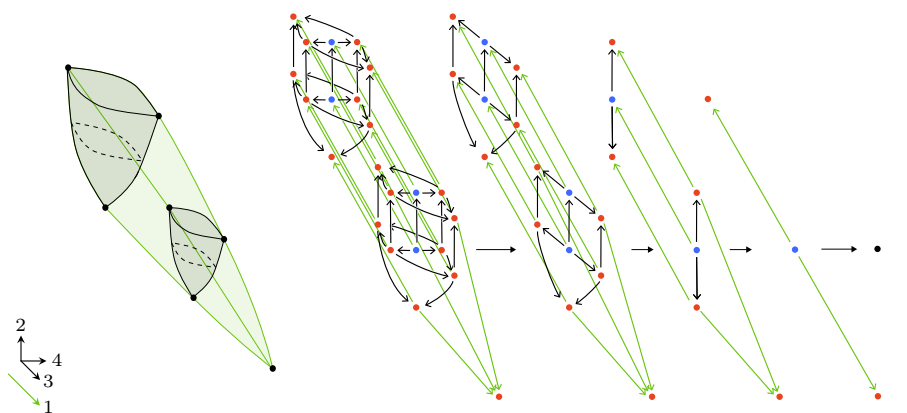

FIGURE C.8. The double cone of the 2-globe as a 4-cell.

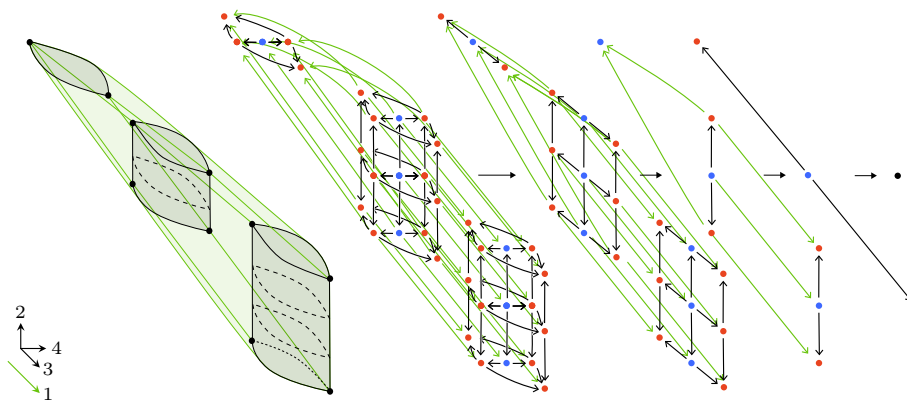

FIGURE C.9. The product of the 2-simplex and the 2-globe as a 4-cell.

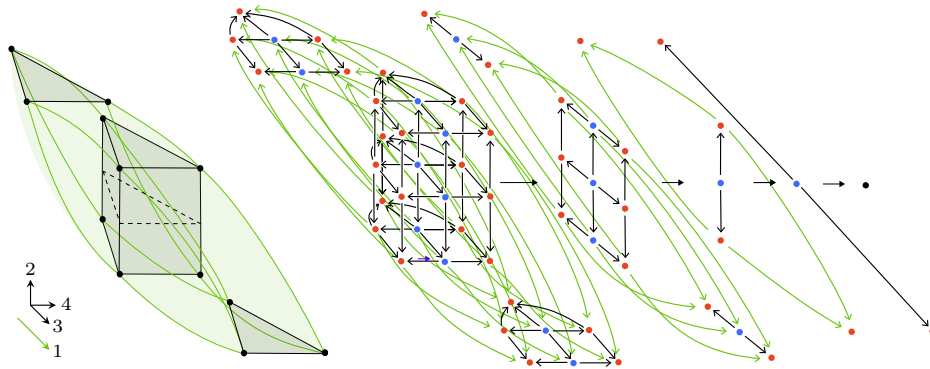

FIGURE C.10. The product of the 2-globe and the 2-simplex as a 4-cell.

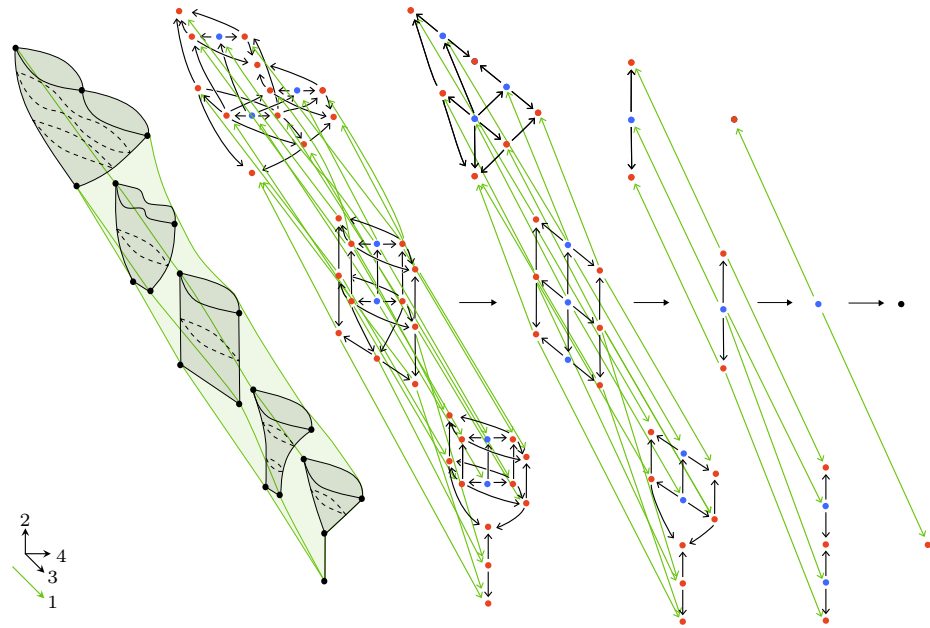

FIGURE C.11. A more involved 4-cell.

BIBLIOGRAPHY

- [AF17] David Ayala and John Francis, *The cobordism hypothesis*, 2017, Available at <https://arxiv.org/abs/1705.02240>.
- [AF24] ———, *The tangle hypothesis: dimension 1*, 2024, Available at <https://arxiv.org/abs/2410.23965>.
- [AFR19] David Ayala, John Francis, and Nick Rozenblyum, *A stratified homotopy hypothesis*, J. Eur. Math. Soc. (JEMS) **21** (2019), no. 4, 1071–1178.
- [AFT17] David Ayala, John Francis, and Hiro Lee Tanaka, *Local structures on stratified spaces*, Adv. Math. **307** (2017), 903–1028.
- [AGV72] Michael Artin, Alexander Grothendieck, and Jean-Louis Verdier, *Théorie des topos et cohomologie étale des schémas (SGA 4), tome 1*, Lecture Notes in Mathematics, vol. 269, Springer-Verlag, 1972.
- [Arn75] Vladimir I. Arnold, *Critical points of smooth functions and their normal forms*, Russian Math. Surveys **30** (1975), no. 5, 1–75.
- [Ban07] Markus Banagl, *Topological invariants of stratified spaces*, Springer Monographs in Mathematics, Springer, 2007.
- [BD95] John C. Baez and James Dolan, *Higher-dimensional algebra and topological quantum field theory*, J. Math. Phys. **36** (1995), no. 11, 6073–6105.
- [Bén67] Jean Bénabou, *Introduction to bicategories*, Reports of the Midwest Category Seminar, Lecture Notes in Mathematics, vol. 47, Springer-Verlag, 1967, pp. 1–77.
- [Bén00] ———, *Distributors at work*, Lecture notes written by Thomas Streicher, 2000.
- [BGH18] Clark Barwick, Saul Glasman, and Peter Haine, *Exodromy*, 2018.
- [Bjö84] Anders Björner, *Posets, regular CW complexes and Bruhat order*, European J. Combin. **5** (1984), no. 1, 7–16.
- [Bjö95] ———, *Topological methods*, Handbook of Combinatorics, vol. 2, Elsevier, 1995, pp. 1819–1872.
- [BLVS⁺99] Anders Björner, Michel Las Vergnas, Bernd Sturmfels, Neil White, and Günter M. Ziegler, *Oriented matroids*, 2nd ed., Encyclopedia of Mathematics and its Applications, no. 46, Cambridge University Press, 1999.
- [Bor94] Francis Borceux, *Handbook of categorical algebra: Volume 2, categories and structures*, Encyclopedia of Mathematics and its Applications, vol. 51, Cambridge University Press, 1994.
- [Bry02] John L. Bryant, *Piecewise linear topology*, Handbook of Geometric Topology (Robert J. Daverman and Richard B. Sher, eds.), North-Holland, 2002, pp. 219–259.
- [BV73] John Michael Boardman and Rainer M. Vogt, *Homotopy invariant algebraic structures on topological spaces*, Lecture Notes in Mathematics, vol. 347, Springer-Verlag, 1973.
- [Can79] James W. Cannon, *Shrinking cell-like decompositions of manifolds. Codimension three*, Ann. of Math. (2) **110** (1979), no. 1, 83–112. MR 541330
- [Cer70] Jean Cerf, *La stratification naturelle des espaces de fonctions différentiables réelles et le théorème de la pseudo-isotopie*, Inst. Hautes Études Sci. Publ. Math. **39** (1970), 5–173.

- [CKS96] J. Scott Carter, Louis H. Kauffman, and Masahico Saito, *Diagrammatics, singularities, and their algebraic interpretations*, 10th Brazilian Topology Meeting (São Carlos, 1996), 1996.
- [CL06] Alexei V. Chernavsky and Vladimir P. Leksine, *Unrecognizability of manifolds*, Ann. Pure Appl. Logic **141** (2006), no. 3, 325–335.
- [CL20] Alexander Campbell and Edoardo Lanari, *On truncated quasi-categories*, Cahiers Topologie Géom. Différentielle Catég. **61** (2020), no. 2, 154–207.
- [Coh73] Marshall M. Cohen, *A course in simple-homotopy theory*, Graduate Texts in Mathematics, vol. 10, Springer-Verlag, 1973.
- [Cos99] Michel Coste, *An introduction to o-minimal geometry*, 1999, Lecture notes, Université de Rennes.
- [CP20] Justin Curry and Amit Patel, *Classification of constructible cosheaves*, Theory and Applications of Categories **35** (2020), no. 27, 1012–1047.
- [CS98] J. Scott Carter and Masahico Saito, *Knotted surfaces and their diagrams*, Mathematical Surveys and Monographs, no. 55, American Mathematical Society, 1998.
- [DHKS04] William G. Dwyer, Philip S. Hirschhorn, Daniel M. Kan, and Jeffrey H. Smith, *Homotopy limit functors on model categories and homotopical categories*, Mathematical Surveys and Monographs, vol. 113, American Mathematical Society, 2004. MR 2102294
- [DK80a] William G. Dwyer and Daniel M. Kan, *Calculating simplicial localizations*, J. Pure Appl. Algebra **18** (1980), no. 1, 17–35.
- [DK80b] ———, *Simplicial localizations of categories*, J. Pure Appl. Algebra **17** (1980), no. 3, 267–284.
- [Don83] Simon K. Donaldson, *An application of gauge theory to four-dimensional topology*, J. Differential Geom. **18** (1983), no. 2, 279–315.
- [Dor18] Christoph Dorn, *Associative n-categories*, Ph.D. thesis, University of Oxford, 2018, Available at <https://ora.ox.ac.uk/objects/uuid:9f9d8668-a48a-4b30-9883-b11e4edbf54>.
- [Dou08] Christopher L. Douglas, *Three-dimensional local field theory*, Topology seminar, M.I.T., 2008.
- [Dug98] Daniel Dugger, *Sheaves and homotopy theory*, 1998, Unpublished preprint, available at <https://pages.uoregon.edu/ddugger/cech.html>.
- [Edw80] Robert D. Edwards, *The topology of manifolds and cell-like maps*, Proceedings of the International Congress of Mathematicians (Helsinki, 1978), Acad. Sci. Fennica, 1980, pp. 111–127.
- [Edw06] ———, *Suspensions of homology spheres*, 2006.
- [EZ50] Samuel Eilenberg and Joseph A. Zilber, *Semi-simplicial complexes and singular homology*, Ann. of Math. (2) **51** (1950), no. 3, 499–513.
- [For98] Robin Forman, *Morse theory for cell complexes*, Adv. Math. **134** (1998), no. 1, 90–145.
- [For02] ———, *A user’s guide to discrete Morse theory*, Sémin. Lothar. Combin. **48** (2002), B48c.
- [For22] Simon Forest, *Unifying notions of pasting diagrams*, Higher Structures **6** (2022), no. 1, 1–79.
- [FP90] Rudolf Fritsch and Renzo Piccinini, *Cellular structures in topology*, Cambridge Studies in Advanced Mathematics, vol. 19, Cambridge University Press, 1990.
- [Fre82] Michael Hartley Freedman, *The topology of four-dimensional manifolds*, J. Differential Geom. **17** (1982), no. 3, 357–453.
- [Fri20] Greg Friedman, *Singular intersection homology*, New Mathematical Monographs, vol. 33, Cambridge University Press, 2020.
- [GM88] Mark Goresky and Robert MacPherson, *Stratified Morse theory*, Ergebnisse der Mathematik und ihrer Grenzgebiete, vol. 14, Springer-Verlag, 1988.

- [GM92] Israel M. Gelfand and Robert D. MacPherson, *A combinatorial formula for the Pontrjagin classes*, Bull. Amer. Math. Soc. (N.S.) **26** (1992), no. 2, 304–309.
- [Gro97] Alexandre Grothendieck, *Esquisse d'un programme*, Geometric Galois Actions (Leila Schneps and Pierre Lochak, eds.), London Mathematical Society Lecture Note Series, vol. 242, Cambridge University Press, 1997, pp. 5–48.
- [Grü03] Branko Grünbaum, *Convex polytopes*, 2nd ed., Graduate Texts in Mathematics, vol. 221, Springer-Verlag, 2003, Prepared by V. Kaibel, V. Klee, and G. M. Ziegler.
- [GWZ86] Herman Gluck, Frank Warner, and Wolfgang Ziller, *The geometry of the Hopf fibrations*, Enseign. Math. (2) **32** (1986), no. 3-4, 173–198.
- [Had24] Amar Hadzihasanovic, *Combinatorics of higher-categorical diagrams*, 2024, Available at <https://arxiv.org/abs/2404.07273>.
- [Hai24] Peter J. Haine, *On the homotopy theory of stratified spaces*, Ann. Sci. Éc. Norm. Supér. (4) **57** (2024), no. 2, 351–384.
- [Hat02] Allen Hatcher, *Algebraic topology*, Cambridge University Press, 2002. MR 1867354
- [HM74] Morris W. Hirsch and Barry Mazur, *Smoothings of piecewise linear manifolds*, Annals of Mathematics Studies, no. 80, Princeton University Press, 1974.
- [Hot65] Günter Hotz, *Eine Algebraisierung des Syntheseproblems von Schaltkreisen I*, Elektron. Informationsverarbeit. Kybernetik **1** (1965), no. 3, 185–205.
- [Hud69] John F. P. Hudson, *Piecewise linear topology*, W. A. Benjamin, 1969, University of Chicago Lecture Notes, prepared with the assistance of J. L. Shaneson and J. Lees.
- [Hum12] Benjamin Taylor Hummon, *Surface diagrams for Gray-categories*, Ph.D. thesis, UC San Diego, 2012.
- [Joy02] André Joyal, *Quasi-categories and Kan complexes*, J. Pure Appl. Algebra **175** (2002), no. 1-3, 207–222.
- [Joy07] ———, *Quasi-categories vs simplicial categories*, 2007, Preprint.
- [JS91] André Joyal and Ross Street, *The geometry of tensor calculus, I*, Adv. Math. **88** (1991), no. 1, 55–112.
- [Kel82] Gregory M. Kelly, *Basic concepts of enriched category theory*, London Mathematical Society Lecture Note Series, vol. 64, Cambridge University Press, 1982.
- [Ker60] Michel A. Kervaire, *A manifold which does not admit any differentiable structure*, Comment. Math. Helv. **34** (1960), 257–270.
- [KS69] Robion C. Kirby and Laurence C. Siebenmann, *On the triangulation of manifolds and the Hauptvermutung*, Bull. Amer. Math. Soc. **75** (1969), no. 4, 742–749.
- [KS77] ———, *Foundational essays on topological manifolds, smoothings, and triangulations*, Annals of Mathematics Studies, no. 88, Princeton University Press, 1977.
- [Lor21] Fosco Loregian, *(co)end calculus*, London Mathematical Society Lecture Note Series, vol. 468, Cambridge University Press, 2021.
- [LR20] Fosco Loregian and Emily Riehl, *Categorical notions of fibration*, Expo. Math. **38** (2020), no. 4, 496–514.
- [Lur09] Jacob Lurie, *Higher topos theory*, Annals of Mathematics Studies, no. 170, Princeton University Press, 2009.
- [Lur17] ———, *Higher algebra*, 2017, Available at <https://www.math.ias.edu/~lurie/papers/HA.pdf>.
- [LW69] Albert T. Lundell and Stephen Weingram, *The topology of CW complexes*, The University Series in Higher Mathematics, Van Nostrand Reinhold Co., 1969.

- [Mac93] Robert D. MacPherson, *Combinatorial differential manifolds*, Topological Methods in Modern Mathematics (Stony Brook, NY, 1991), Publish or Perish, 1993, pp. 203–221.
- [Man16] Ciprian Manolescu, *Pin(2)-equivariant Seiberg–Witten Floer homology and the triangulation conjecture*, J. Amer. Math. Soc. **29** (2016), no. 1, 147–176.
- [Mar58] Andrei Andreevich Markov, *The insolubility of the problem of homeomorphy*, Dokl. Akad. Nauk SSSR **121** (1958), no. 2, 218–220.
- [Mau96] Charles R. F. Maunder, *Algebraic topology*, Dover Publications, 1996.
- [Mil56] John W. Milnor, *On manifolds homeomorphic to the 7-sphere*, Ann. of Math. (2) **64** (1956), 399–405.
- [Mil61] ———, *Two complexes which are homeomorphic but combinatorially distinct*, Ann. of Math. (2) **74** (1961), 575–590.
- [Mil63] ———, *Morse theory*, Annals of Mathematics Studies, vol. 51, Princeton University Press, 1963.
- [MLM92] Saunders Mac Lane and Ieke Moerdijk, *Sheaves in geometry and logic: A first introduction to topos theory*, Universitext, Springer-Verlag, 1992.
- [Moi52] Edwin E. Moise, *Affine structures in 3-manifolds. V. The triangulation theorem and Hauptvermutung*, Ann. of Math. (2) **56** (1952), no. 1, 96–114. MR 0048805
- [MS22] Laurențiu G. Maxim and Jörg Schürmann, *Constructible sheaf complexes in complex geometry and applications*, Handbook of Geometry and Topology of Singularities III, Springer, 2022, pp. 679–791.
- [Pac91] Udo Pachner, *PL homeomorphic manifolds are equivalent by elementary shellings*, European J. Combin. **12** (1991), no. 2, 129–145.
- [Pen71] Roger Penrose, *Applications of negative dimensional tensors*, Combinatorial mathematics and its applications **1** (1971), 221–244.
- [Pfl01] Markus J. Pflaum, *Analytic and geometric study of stratified spaces*, Lecture Notes in Mathematics, vol. 1768, Springer, 2001.
- [Qui67] Daniel G. Quillen, *Homotopical algebra*, Lecture Notes in Mathematics, vol. 43, Springer-Verlag, 1967.
- [RCS⁺96] Andrew A. Ranicki, Andrew J. Casson, Dennis P. Sullivan, Mark A. Armstrong, Colin P. Rourke, and George E. Cooke, *The Hauptvermutung book*, K-Monographs in Mathematics, vol. 1, Kluwer Academic Publishers, 1996, A collection of papers on the topology of manifolds. MR 1434100
- [Rez22] Charles Rezk, *Introduction to quasicategories*, 2022, Lecture notes, University of Illinois at Urbana-Champaign.
- [Rie14] Emily Riehl, *Categorical homotopy theory*, New Mathematical Monographs, vol. 24, Cambridge University Press, 2014. MR 3221774
- [Ros98] Dennis Roseman, *Reidemeister-type moves for surfaces in four-dimensional space*, Banach Center Publ. **42** (1998), 347–380.
- [RS71] Colin P. Rourke and Brian J. Sanderson, *Δ -sets. I. Homotopy theory*, Quart. J. Math. Oxford Ser. (2) **22** (1971), 321–338. MR 300281
- [RS72] ———, *Introduction to piecewise-linear topology*, Ergebnisse der Mathematik und ihrer Grenzgebiete, vol. 69, Springer-Verlag, 1972.
- [Shi14] Masahiro Shiota, *O-minimal Hauptvermutung for polyhedra I*, Invent. Math. **196** (2014), no. 1, 163–232.
- [Sta12] Richard P. Stanley, *Enumerative combinatorics, volume 1*, 2nd ed., Cambridge Studies in Advanced Mathematics, no. 49, Cambridge University Press, 2012.
- [Ste93] Richard Steiner, *The algebra of directed complexes*, Appl. Categ. Structures **1** (1993), no. 3, 247–284.
- [Sto68] Robert E. Stong, *Notes on cobordism theory*, Mathematical Notes, Princeton University Press, 1968.

- [Str01] Ross Street, *Powerful functors*, Unpublished expository notes, available at <http://web.science.mq.edu.au/~street/Pow.fun.pdf>, 2001.
- [Str09] Neil P. Strickland, *The category of CGWH spaces*, 2009, Preprint.
- [Tho75] René Thom, *Structural stability and morphogenesis: An outline of a general theory of models*, Cummings Publishing Company, 1975.
- [Tre09] David Treumann, *Exit paths and constructible stacks*, *Compos. Math.* **145** (2009), no. 6, 1504–1532.
- [Tri99] Todd Trimble, *Surface diagrams*, 1999, nLab, available at <https://ncatlab.org/nlab/show/surface+diagram>.
- [vdD86] Lou van den Dries, *A generalization of the Tarski-Seidenberg theorem, and some nondefinability results*, *Bull. Amer. Math. Soc. (N.S.)* **15** (1986), no. 2, 189–193. MR 854552
- [VdD98] Lou Van den Dries, *Tame topology and o-minimal structures*, London Mathematical Society Lecture Note Series, vol. 248, Cambridge University Press, 1998.
- [vdDMM94] Lou van den Dries, Angus Macintyre, and David Marker, *The elementary theory of restricted analytic fields with exponentiation*, *Ann. of Math. (2)* **140** (1994), no. 1, 183–205. MR 1289495
- [VKF74] Igor' Aleksandrovich Volodin, V. E. Kuznetsov, and Anatoly Timofeevich Fomenko, *The problem of discriminating algorithmically the standard three-dimensional sphere*, *Russian Math. Surveys* **29** (1974), no. 5, 71–172, With an appendix by S. P. Novikov.
- [War96] Joe Warren, *Barycentric coordinates for convex polytopes*, *Adv. Comput. Math.* **6** (1996), no. 1, 97–108.
- [Wei94] Shmuel Weinberger, *The topological classification of stratified spaces*, University of Chicago Press, 1994.
- [Wei05] ———, *Computers, rigidity, and moduli: The large-scale fractal geometry of Riemannian moduli space*, Princeton University Press, 2005.
- [Whi39] John H. C. Whitehead, *Simplicial spaces, nuclei and m -groups*, *Proc. London Math. Soc. (2)* **45** (1939), no. 1, 243–327.
- [Whi40] ———, *On C^1 -complexes*, *Ann. of Math. (2)* **41** (1940), 809–824.
- [Wil96] Alex J. Wilkie, *Model completeness results for expansions of the ordered field of real numbers by restricted Pfaffian functions and the exponential function*, *J. Amer. Math. Soc.* **9** (1996), no. 4, 1051–1094. MR 1398816
- [Woo09] Jon Woolf, *The fundamental category of a stratified space*, *J. Homotopy Relat. Struct.* **4** (2009), no. 1, 359–387. MR 2591969
- [Zie95] Günter M. Ziegler, *Lectures on polytopes*, Graduate Texts in Mathematics, vol. 152, Springer-Verlag, 1995.

LIST OF FIGURES

I.1	A closed 2-truss and an open 3-truss.	xv
I.2	Framed regular 2-cells and their classifying truss blocks.	xvi
I.3	Framed regular 3-cells and their classifying truss blocks.	xvii
I.4	A closed 2-mesh and an open 3-mesh.	xviii
I.5	A subdivision of a framed regular cell.	xix
I.6	Dualization of meshes.	xx
I.7	Two tame stratifications of the 4-cube.	xxi
I.8	The coarsest mesh refining the third Reidemeister move.	xxi
I.9	The coarsest mesh refining the swallowtail singularity.	xxii
I.10	A tame stratification with its normalized stratified truss.	xxiii
I.11	Overview of concepts and connections.	xxv
I.12	Overview of dependencies.	xxvi
1.1	Distinct framed simplices spanned by the same frame vectors.	3
1.2	Linear algebra to affine combinatorics analogy.	9
1.3	Frames in linear algebra and affine combinatorics.	10
1.4	Framed simplices.	10
1.5	Framed realization of framed simplices.	12
1.6	The 1-partially framed 2-simplices and 3-simplices.	13
1.7	Half of the 2-partially framed 3-simplices.	13
1.8	Framed realization of partially framed simplices.	14
1.9	Embedded framed simplices.	16
1.10	Framed realization of the 3-embedded framed 1-simplices.	16
1.11	Framed realization of the 3-embedded framed 2-simplices.	17
1.12	Embedded partially framed simplices.	18
1.13	Framed realization of embedded partially framed simplices.	18
1.14	Restriction of embedded frames to vectors of 3-simplices.	20
1.15	Restriction of frames to vectors of 4-simplices.	20
1.16	Restriction of a frame to faces of a simplex.	21
1.17	Framed maps of framed simplices.	23
1.18	Non-framed maps of framed simplices.	24
1.19	Framed maps via framed realization.	24

1.20	Subframed maps via their framed realizations.	26
1.21	A framed simplicial complex and a differential singularity.	28
1.22	Simplicial complexes with a 2-framing.	32
1.23	Simplicial complexes with no 2-framing.	32
1.24	Simplicial complexes with 2-framings and their framed realizations.	33
1.25	Highest frame vectors of framed simplices.	36
1.26	Collapse of highest frame vectors.	37
1.27	Collapsible 1-framed simplicial complexes.	38
1.28	Collapsible 2-framed simplicial complexes.	38
1.29	Non-collapsible 1-framed simplicial complexes.	39
1.30	Non-collapsible 2-framed simplicial complexes.	39
1.31	Progressive framed simplicial manifolds.	40
1.32	Non-progressive framed simplicial manifolds.	40
1.33	Framed cell complex and corresponding framed simplicial complex.	42
1.34	Regular 2-cells and regular 3-cells.	44
1.35	Cellular posets.	45
1.36	Non-cellular posets.	45
1.37	Cellular maps of regular cells.	47
1.38	Non-cellular maps of regular cells.	48
1.39	Regular cell complex, cellular poset, and simplicial complex.	49
1.40	A 2-framed regular cell complex.	52
1.41	Collapsible subcomplexes of a 2-framed regular cell complex.	53
1.42	A 2-framed regular cell complex with a framed realization.	53
1.43	Framed realization of a framed regular cell complex.	54
1.44	Collapsible and non-collapsible framed regular cell complexes.	55
1.45	2-Framed regular 1-cells.	56
1.46	2-Framed regular 2-cells.	56
1.47	Framings of 1-cell subdivisions that are not framed regular cells.	57
1.48	Framings of 2-cell subdivisions that are not framed regular cells.	57
1.49	The simplest framed regular 3-cell.	58
1.50	Framing of a 3-globe subdivision that is not a framed regular cell.	58
1.51	Simple framed regular 3-cells.	59
1.52	Realizations of regular 3-cells that are not framed regular cells.	59
1.53	More framed regular 3-cells.	60
1.54	Yet more framed regular 3-cells.	60
1.55	The framed regular cell complex dual to the Hopf circle.	61

1.56	Highest frame and axel vectors of framed regular 1-cells and 2-cells.	62
1.57	Axel vectors of framed regular 3-cells.	62
1.58	Framed cellular maps.	63
1.59	Cellular maps that are not framed.	64
1.60	A framed cellular map and its subframed simplicial map.	64
1.61	Framed simplicial complexes and their framed cell complexes.	66
1.62	Acyclicity of 1-directed graphs via framed realization.	70
2.1	A 1-truss, a 1-truss bordism, and a 1-truss bordism composition.	73
2.2	The total poset of a 1-truss bundle.	73
2.3	Fences of different types.	75
2.4	1-Trusses of different types.	76
2.5	1-Trusses and their corresponding stratified intervals.	77
2.6	Types of maps of 1-trusses.	78
2.7	Endpoint types of 1-trusses.	80
2.8	Bundles of stratified intervals and their 1-truss bordisms.	81
2.9	A 1-truss bordism.	84
2.10	Not a 1-truss bordism.	84
2.11	A 1-truss bordism cospan.	85
2.12	Local forms of 1-truss bordisms.	87
2.13	Fixable failures of truss bifunctionality.	87
2.14	Irredeemable infractions of truss bifunctionality.	88
2.15	Brutal breakdowns of truss bimonotonicity.	89
2.16	Composition of 1-truss bordisms.	90
2.17	Dual 1-truss bordisms.	91
2.18	1-truss maps and their mapping (co)cylinder 1-truss bordisms.	96
2.19	A 1-truss bundle and its generating arrows.	99
2.20	A 1-truss bundle over a category.	101
2.21	A singular and a regular 1-truss bundle map.	102
2.22	A 1-truss bundle and its classifying functor.	104
2.23	1-Truss bordism composition as a bundle over the 2-simplex.	104
2.24	The pullback of a 1-truss bundle along a base poset inclusion.	107
2.25	Suspension bundle of a 1-truss bundle.	109
2.26	The scaffold order for a 1-truss bundle.	111
2.27	Sections and spacers in a 1-truss bundle.	113
2.28	Spine notation for sections and spacers.	113
2.29	Sections and their associated jump morphisms.	116

2.30	Spacers and their associated fiber morphisms.	117
2.31	The scaffold order on sections.	118
2.32	The construction of successor sections.	121
2.33	The scaffold order on spacers.	122
2.34	Upper and lower boundaries of spacers.	123
2.35	A labeled 1-truss bordism.	126
2.36	Failure of composition of labeled functorial relations.	127
2.37	Composition of labeled 1-truss bordisms.	128
2.38	A 1-truss bundle labeled in a poset.	133
2.39	A 1-truss bundle labeled in a monoid.	133
2.40	A labeled 1-truss bundle and its classifying functor.	136
2.41	A 3-truss and its corresponding stratifications.	141
2.42	A 2-truss and corresponding stratifications.	142
2.43	A labeled open 3-truss.	143
2.44	A 2-truss bordism.	144
2.45	A labeled 2-truss bordism.	145
2.46	Composition of 2-truss bordisms.	148
2.47	The classifying tower of a 3-truss.	157
2.48	Faces, embeddings, degeneracies, and coarsenings.	165
2.49	Epi-mono factorization of a closed singular 2-truss map.	166
2.50	Failure of epi-mono factorization of a 2-truss map.	167
2.51	A 2-truss 2-block and its corresponding framed 2-cell.	168
2.52	A 3-truss 3-block and its corresponding framed 3-cell.	169
2.53	Face blocks in a 2-truss.	171
2.54	A block set and a block complex.	173
2.55	A regular block complex.	173
2.56	A 2-truss 0-brace.	175
3.1	A framed regular cell and its corresponding truss block.	178
3.2	A collapsible framed regular cell complex and its closed truss.	179
3.3	A framed regular cell complex and its truss block complex.	179
3.4	A proframed simplicial complex.	180
3.5	Proframed simplices.	182
3.6	A proframed 4-simplex.	182
3.7	Partially proframed simplices.	182
3.8	Embedded proframes on simplices.	183
3.9	Proframed realizations of proframed simplices.	185

3.10	The gradient frame and the integral proframe.	187
3.11	2-Proframings of simplicial complexes.	189
3.12	Proframed simplicial complex with its gradient framing.	191
3.13	Two framings without integral proframings.	191
3.14	Fiber categories and transition functors.	193
3.15	A shelling of a regular cell boundary.	196
3.16	Framed regular section and spacer cells.	198
3.17	The projected 2-framed cell of a 3-framed cell.	201
3.18	Inductive shelling of the boundary of a truss block.	206
4.1	A 3-mesh.	212
4.2	Trivial, linear, and circular 1-meshes.	215
4.3	Types of maps of 1-meshes.	217
4.4	A 1-mesh bundle over the stratified 1-simplex.	219
4.5	A 1-mesh bundle over a poset realization.	220
4.6	A categorical 1-mesh bundle.	223
4.7	Local forms of 1-mesh bundles.	225
4.8	Mild mesh mishaps of constructible continuity.	225
4.9	Lamentable lapses of liftability.	226
4.10	Brazen breaches of boundaries.	227
4.11	Subtle skews of mesh lift uniqueness.	227
4.12	1-Mesh bundle map.	228
4.13	The compactification of a 1-mesh bundle.	230
4.14	2-Meshes and their framed realizations.	234
4.15	An open 3-mesh.	235
4.16	A 3-mesh map.	238
4.17	A corresponding 3-mesh and 3-truss.	243
4.18	Failure of continuity of an interpolated bundle isomorphism.	255
4.19	The regular contour of a regular stratum.	256
4.20	Catchment areas for cells and their radial decompositions.	257
4.21	1-Mesh bundle realization of a 1-truss bundle.	264
4.22	Cubical compactification of an open 2-truss.	266
4.23	The mesh realization of an open 2-truss.	267
4.24	Framed subdivisions and non-framed subdivisions.	281
4.25	Mesh realizations of combinatorial subdivisions.	283
4.26	A mesh block and its dual mesh brace.	285
4.27	A closed mesh and its dual open mesh.	285

5.1	A tame stratification and a tame embedding.	287
5.2	2-Tame stratifications.	289
5.3	2-Tame embeddings.	290
5.4	3-Tame stratifications.	290
5.5	3-Tame embeddings.	291
5.6	Tame and untame oscillations.	291
5.7	Nonlocal untameness.	292
5.8	Framed stratified homeomorphism.	294
5.9	Non-framed stratified homeomorphism.	294
5.10	A framed substratification.	295
5.11	A tame stratification and its coarsest refining mesh.	300
5.12	Joins of stratifications.	302
5.13	The join of two open meshes.	304
5.14	A categorical 1-mesh bundle as a join.	304
5.15	Refining meshes and a minimal coarsest refining mesh.	311
5.16	Refining meshes of a tame stratification.	313
5.17	Refining meshes of a tame embedding.	313
5.18	The coarsest refining mesh of two 2-tame stratifications.	313
5.19	The minimal coarsest refining mesh of two 2-tame embeddings.	314
5.20	Coarsest meshes of 3-tame stratifications.	314
5.21	Minimal coarsest meshes of 3-tame embeddings.	315
5.22	The cusp embedding and its normalized ambient stratified truss.	317
5.23	A stratified 2-truss.	318
5.24	A stratified truss represented by a poset labeling.	319
5.25	An ambient stratified 2-truss.	320
5.26	A truss coarsening of stratified trusses.	321
5.27	Truss singularities.	321
5.28	A mesh coarsening of stratified meshes.	323
5.29	Mesh singularities.	323
5.30	Mesh cells.	324
5.31	Classifying 2-tame stratifications and embeddings.	327
5.32	The normalized stratified truss of a 3-tame stratification.	328
5.33	The normalized ambient stratified truss of the braid.	329
5.34	Tame stratified bundles and tame bundle embeddings.	331
5.35	Construction of mesh refinements for polyhedral stratifications.	334
5.36	Confluence of truss coarsenings.	341

5.37	Tame singularities and their dual tame cells.	345
5.38	Duality of tame stratifications.	345
5.39	Degeneracies of tame stratifications.	347
5.40	Coarsest cell structure of a tamely embedded circle.	350
5.41	Decidability of framed homeomorphism for 1-DAGs.	350
5.42	A manifold diagram and a tame tangle.	351
5.43	Framed conical and not framed conical stratifications.	354
5.44	Framed conical and not framed conical embeddings.	354
5.45	Genericity of framings on the embedded interval.	355
5.46	A manifold diagram and not a manifold diagram.	357
5.47	A manifold 3-diagram isotopy.	358
5.48	Tame tangles and their refining manifold diagrams.	361
5.49	Two tangle singularities in a tame 2-tangle.	363
5.50	A projection of a 3-tangle singularity and its critical refinement.	363
5.51	A 1-tangle isotopy.	364
5.52	Perturbation of a monkey saddle into two ordinary saddles.	365
A.1	A corresponding indframe and proframe.	370
A.2	The standard indframe and proframe.	370
A.3	Orthonormal frame, oriented indframe, and oriented proframe.	373
A.4	A 1-partial trivialization, frame, indframe, and proframe.	378
A.5	A 3-embedded trivialization, frame, indframe, and proframe.	379
A.6	Embedded partial trivialization, frame, indframe, and proframe.	379
B.1	Fundamental poset of a stratification.	387
B.2	The fundamental poset as a transitive closure.	387
B.3	A prestratification and its formal entrance path relation.	387
B.4	A stratified bundle encoded as a covariant functor.	388
B.5	A stratification with non-continuous characteristic function.	391
B.6	A connected-quotient map and two non-connected-quotient maps.	393
B.7	A poset structure with non-continuous splitting.	396
B.8	Stratified realizations of posets.	398
B.9	A stratified map and a non-stratified map.	399
B.10	A coarsening and its corresponding refinement of stratifications.	399
B.11	Two substratifications and a non-substratification.	400
B.12	Beware pullbacks of stratifications.	405
B.13	A conical stratification with a tubular neighborhood.	407
B.14	A conical and a non-conical stratification of a cone.	407

B.15	A cellular link and cellular star in a regular cell complex.	413
B.16	Conical subdivision in a regular cell complex.	415
B.17	Fundamental categories of two stratified circles.	416
C.1	The simplest 2-cells.	418
C.2	The simplest 3-cells projecting to the 2-globe.	420
C.3	The simplest 3-cells projecting to the 2-simplex.	421
C.4	Further 3-cells projecting to the 2-simplex.	422
C.5	The simplest 3-cells projecting to the 2-cube.	423
C.6	More exotic 3-cells and their dual open meshes.	424
C.7	The 4-globe as a 4-cell.	425
C.8	The double cone of the 2-globe as a 4-cell.	425
C.9	The product of the 2-simplex and the 2-globe as a 4-cell.	425
C.10	The product of the 2-globe and the 2-simplex as a 4-cell.	426
C.11	A more involved 4-cell.	426

LIST OF NOTATION

Chapter 1

\mathcal{F}	A frame structure. \rightsquigarrow -index: \triangleright framed simplex, \triangleright framed simplicial complex, \triangleright framed regular cell complex.	§1
$\mathcal{F} _X$	The restriction of a frame structure. \rightsquigarrow -index: \triangleright restricted frame.	§1
$r_{\mathcal{F}}$	Realization of a frame structure \mathcal{F} .	§1
Δ	The category of ordered simplices.	1.1.2
$\underline{\Delta}$	The category of unordered simplices.	1.1.3
$(-)^{\text{un}}$	The unordering functor, forgetting the order of ordered simplices.	1.1.4
$S \hookrightarrow T$	A face map between simplices.	1.1.5
$S \twoheadrightarrow T$	A degeneracy map between simplices.	1.1.5
$[m]$	The combinatorial standard ordered m -simplex.	1.1.7
$[m]^{\text{un}}$	The unordered standard simplex.	1.1.9
\underline{m}	The ordered set $1 < 2 < \dots < m$.	1.1.10
spine S	The ordered collection of spine vectors of an ordered simplex.	1.1.14
spine $[m]$	The spine of the standard simplex.	1.1.15
$\ker(S \twoheadrightarrow T)$	The kernel of a degeneracy or projection.	1.1.16
$\ker^{\text{aff}}(S \twoheadrightarrow T)$	The affine kernel of a degeneracy between ordered simplices.	1.1.17
$S \hookleftarrow T$	An affine face map between ordered simplices.	1.1.18
$\text{im}^{\text{aff}}(f)$	The affine image of an affine face map.	1.1.19
$\text{coker}^{\text{aff}}(f)$	The affine cokernel of an affine face map.	1.1.20
$ S $	The geometric simplex of an unordered simplex	1.1.27
ϵ_i^{\pm}	The i th positive or negative standard component of \mathbb{R}^n .	1.1.28
FrSimp $_n$	The category of n -embedded framed simplices and their framed maps.	1.1.67
PartFrSimp $_n$	The category of n -embedded partially framed simplices and their framed maps.	1.1.73
SimpCplx	The category of simplicial complexes and their simplicial maps.	1.2.2
SimpCplx ^{ord}	The category of ordered simplicial complexes and their simplicial maps.	1.2.4
FrSimpCplx $_n$	The category of n -framed simplicial complexes and framed maps.	1.2.17
Unframe	A functor that takes a framed simplicial complex to its underlying simplicial complex.	1.2.18
$h^{\mathcal{F}}$	The highest frame vector of a framed simplex.	1.2.26
q_k	The framed k -collapse map, resulting from a sequence of framed elementary k -collapses.	1.2.31
CollFrSimpCplx $_n$	The full subcategory of n -framed simplicial complexes comprising collapsible framings.	1.2.34

$P^{>x}$	The strict upper closure of an element x in a poset P , consisting of elements $y \in P$ such that $y > x$.	1.3.2
$P^{\geq x}$	The upper closure of an element x in a poset P , consisting of elements $y \in P$ such that $y \geq x$.	1.3.2
NP	The nerve of a poset P .	1.3.3
$ P $	Geometric realization of a poset P .	1.3.3
$\ P\ $	The stratified realization of a poset P .	1.3.4
$\text{str}(x)$	The stratum in a stratified realization corresponding to the poset object x .	1.3.4
$\sqcap X$	The fundamental poset of a regular cell complex X	1.3.10
\perp_X	The initial object of a combinatorial regular m -cell.	1.3.17
CellCplx^S	The category of geometric regular cell complexes.	1.3.20
CellCplx	The category of combinatorial regular cell complexes.	1.3.23
CellCplx^S	The topological category of geometric regular cell complexes and their cellular maps.	1.3.26
$\mathbb{F}K$	The face poset of a simplicial complex K .	1.3.30
$\text{axel } x$	The subcomplex spanned by the highest frame vectors of a framed regular cell. \rightsquigarrow index: $\triangleright \text{axel vector}$.	1.3.52
FrCell_n	The category of n -framed regular cells.	1.3.60
FrCellCplx_n	The category of n -framed regular cell complexes.	1.3.60
CollFrCellCplx_n	The category of collapsible n -framed regular cell complexes.	1.3.60

Chapter 2

\triangleleft	The face order of a truss.	§2
\trianglelefteq	The frame order of a truss.	§2
\dim	The dimension map of a truss.	§2
\dagger	The dualization functor. \rightsquigarrow index: $\triangleright \text{dualization functor}$, $\triangleright \text{dual truss}$, $\triangleright \text{dual truss bundle}$, $\triangleright \text{dual truss bordism}$.	§2
χ_-	The classification functor, taking a (labeled) truss bundle to its classifying functor.	§2
π_-	The totalization functor, taking a classifying functor to its total truss bundle.	§2
lbl_X	A labeling structure of X . \rightsquigarrow index: $\triangleright \text{labeling functor}$, $\triangleright \text{C-labeling}$.	§2
$\text{reg}(T)$	The subset of regular elements of a truss. \rightsquigarrow index: $\triangleright \text{regular element set}$.	2.1.13
$\text{sing}(T)$	The subset of singular elements of a truss. \rightsquigarrow index: $\triangleright \text{singular element set}$.	2.1.13
Tr_1	The category of 1-trusses.	2.1.19
$\text{end}_{\pm} T$	The minimal and maximal element of the frame order of a 1-truss, referred to as the lower and upper endpoint.	2.1.22
$\overline{\mathbb{T}}_k$	The left-closed right-open 1-truss with $2k$ elements.	2.1.23
$\overline{\mathbb{T}}_0$	The trivial closed 1-truss, which has a single, singular element.	2.1.23
\mathbb{T}_k	The closed 1-truss with $2k + 1$ elements.	2.1.23
$\overline{\mathbb{T}}_k$	The left-open right-closed 1-truss with $2k$ elements.	2.1.23
\mathbb{T}_0	The trivial open 1-truss, which has a single, regular element.	2.1.23
$\mathring{\mathbb{T}}_k$	The open 1-truss with $2k + 1$ elements.	2.1.23
$\mathring{\text{Tr}}_1$	The category of open trusses and regular maps.	2.1.25

$\bar{\text{Tr}}_1$	The category of closed trusses and singular maps.	2.1.25
\rightarrow	A functorial relation between preorders, or a profunctor between categories.	2.1.30
reg^R	The regular function of a 1-truss bordism R , mapping regular elements from the target truss S to regular elements in the source truss T .	2.1.34
sing_R	The singular function of a 1-truss bordism R , mapping singular elements from the source truss T to singular elements in the target truss S .	2.1.34
Bool	The category of boolean values, whose objects are ‘true’ \top and ‘false’ \perp .	2.1.38
BoolProf	The category of preorders and their boolean profunctors.	2.1.39
rel	The underlying relation functor.	2.1.40
TBord ¹	The category of 1-trusses and their bordisms.	2.1.53
$\text{Tr}_1^{r,\theta}$	The category of 1-trusses and their regular maps that preserve regular endpoints.	2.1.67
$\text{Tr}_1^{s,\theta}$	The category of 1-trusses and their singular maps that preserve singular endpoints.	2.1.67
Cyl	The mapping cylinder functor.	2.1.68
coCyl	The mapping cocylinder functor.	2.1.68
R	The associated total poset of a 1-truss bordism R .	2.1.73
$p : T \rightarrow B$	A 1-truss bundle with total poset T and base poset B .	2.1.74
$\text{cov}(B)$	The covering relation of the poset B .	2.1.81
TrsBun ₁	The category of 1-truss bundles.	2.1.90
$\text{Tr}_1(B)$	The category of 1-truss bundles over a fixed base poset B and their base-preserving maps.	2.1.90
$\overset{\circ}{\text{Tr}}_1(B)$	The category of open truss bundles over a fixed base poset B and their regular maps.	2.1.90
$\bar{\text{Tr}}_1(B)$	The category of closed truss bundles over a fixed base poset B and their singular maps.	2.1.90
Tot F	The total poset of the bundle classified by F . \rightsquigarrow index: \triangleright totalization functor.	2.1.93
π_F	The total 1-truss bundle of a classifying functor F . \rightsquigarrow index: \triangleright totalization functor.	2.1.93
TBord ¹ (B)	The category of 1-truss bundles and their bordisms over a fixed base poset B .	2.1.97
G^*p	The pullback of a truss bundle p along a map G . \rightsquigarrow index: \triangleright pullback truss bundle.	2.1.103
ΣX	The suspension of a poset X , obtained by adjoining initial and final elements.	2.1.110
Σp	The suspension of a truss bundle $p : T \rightarrow B$.	2.1.111
Γ_p	The set of sections of a 1-truss bundle $p : T \rightarrow [m]$.	2.2.10
Ψ_p	The set of spacers of a 1-truss bundle $p : T \rightarrow [m]$.	2.2.10
$\langle - \rangle$	The scaffold norm of a section or spacer simplex. \rightsquigarrow index: \triangleright scaffold norm of sections, \rightsquigarrow index: \triangleright scaffold norm of spacers.	2.2.25
\mathcal{K}_p^\pm	The bottom and top sections of a 1-truss bundle $p : T \rightarrow [m]$.	2.2.28
$\partial_\pm L$	The upper and lower boundary sections of a spacer L .	2.2.31
$\Phi_p(z)$	The fiber category in a 1-truss bundle $p : T \rightarrow B$ over a nondegenerate simplex $z : [m] \rightarrow B$.	2.2.36

$(-)$	The label-forgetting functor. \rightsquigarrow -index: \triangleright <i>label-forgetting functor</i> , \triangleright <i>underlying truss</i> , \triangleright <i>underlying truss bordism</i> , \triangleright <i>underlying truss bundle</i> .	2.2.49
\underline{T}	See $(-)$.	2.2.49
$\mathbb{T}\text{Bord}^1_{// -}$	The labeled 1-truss bordism endofunctor on categories. \rightsquigarrow -index: \triangleright <i>relabeling functor</i> , \triangleright <i>labeled 1-truss bordism functor</i> , \triangleright <i>category of labeled 1-trusses and their bordisms</i> .	2.2.50
ι	The bordism-as-profunctor pseudofunctor.	2.2.51
$H_{// C}$	The vertical comma category of a normal pseudofunctor H from a category T to the bicategory $\mathbb{P}\text{rof}$, over a category C in $\mathbb{P}\text{rof}$.	2.2.53
$p _A$	The restriction of a labeled truss bundle.	2.2.65
$\mathbb{T}\text{Bord}(B)_{// C}$	The category of C -labeled 1-truss bundles over a base poset B and their bordisms.	2.2.71
$\mathcal{F}\text{Bord}^1_{// -}$	The labeled 1-truss bordism endofunctor on quasicategories.	2.2.75
$\text{cod}(R)$	The codomain of a labeled n -truss bordism R .	2.3.13
$\text{dom}(R)$	The domain of a labeled n -truss bordism R .	2.3.13
rel_k^R	The k -stage functorial relation of an n -truss bordism R .	2.3.14
$n\mathbb{T}\text{Bord}_{// C}$	The category of C -labeled n -trusses and their bordisms.	2.3.20
$\mathbb{T}\text{Bord}^n_{// -}$	The n -fold iterated labeled 1-truss bordism functor.	2.3.23
$\text{cov}(T_k)$	The generating arrows of an n -truss bundle.	2.3.30
Tr_n	The category of n -trusses.	2.3.38
LblTr_n	The category of labeled n -trusses.	2.3.38
TrsBun_n	The category of n -truss bundles.	2.3.38
LblTrsBun_n	The category of labeled n -truss bundles.	2.3.38
$\text{Tr}_n(B)$	The category of n -truss bundles over a poset B and base-preserving maps.	2.3.38
$\overset{\circ}{\text{Tr}}_n(B)$	The category of open n -truss bundles and their regular maps.	2.3.38
$\bar{\text{Tr}}_n(B)$	The category of closed n -truss bundles and their singular maps.	2.3.38
$\mathcal{F}\text{tr}_n$	The $k\text{Top}$ -enriched category of n -trusses.	2.3.39
$\mathcal{F}\text{tr}_n(B)$	The $k\text{Top}$ -enriched category of n -truss bundles over a poset B and base-preserving maps.	2.3.39
$p_{>k}$	The upper truncation of a labeled n -truss bundle p .	2.3.42
$p_{\leq k}$	The lower truncation of a labeled n -truss bundle p .	2.3.43
$n\mathbb{T}\text{Bord}(B)_{// C}$	The category of C -labeled n -truss bundles over a base poset B and their bordisms.	2.3.50
$q \times T$	The truss product of an unlabeled m -truss bundle q and a C -labeled n -truss T .	2.3.55
Tr_n^{crs}	The category of n -trusses and their coarsenings.	2.3.66
Tr_n^{deg}	The category of n -trusses and their degeneracies.	2.3.66
\perp	The initial element in the total poset of a block.	2.3.73
Blk_n	The category of n -truss blocks and singular maps.	2.3.78
\mathbb{X}	The category of blocks.	2.3.79
$T^{\triangleright x}$	The face block of an element x in a truss T .	2.3.81
BlkSet_n	The category of n -truss block sets.	2.3.85
$\widehat{\mathbb{X}}$	The category of block sets.	2.3.87
BlkCplx_n	The category of block complexes.	2.3.92

RBlkCplx_n	The category of regular block complexes.	2.3.92
Brc_n	The category of n -truss braces and regular maps.	2.3.105
\mathbb{X}	The category of braces.	2.3.106
BrcSet_n	The category of n -truss brace sets.	2.3.108
$\widehat{\mathbb{X}}$	The category of brace sets.	2.3.110

Chapter 3

$\nabla_{\mathbb{C}}$	The cell gradient functor, which takes a truss block to its framed regular cell.	§3
$\int_{\mathbb{T}}$	The truss integration functor, which takes a framed regular cell to its truss block.	§3
\mathcal{P}	A proframe structure. \rightsquigarrow -index: \triangleright proframe on a simplex, \triangleright proframed simplicial complex.	3.2.1
p_{\perp}	The initial degeneracy of a k -partial proframe.	3.2.3
$\mathcal{P}_{\mathbb{R}}^n$	The standard euclidean proframe of \mathbb{R}^n .	3.2.8
$r_i^{\mathcal{P}}$	A sequence of linear embeddings forming a proframed realization.	3.2.9
ProFrSimp_n	The category of n -embedded proframed simplices and their proframed maps.	3.2.12
$p \rightarrow i$	Composite projection $p_{i+1} \cdots p_n : [m] \rightarrow [m_i]$ in an n -embedded proframed simplex. This differs from \triangleright upper truncation of a tower of bundles.	3.2.14
∇	The gradient frame (or framing) functor.	3.2.15
\int	An integral proframe (or proframing) construction.	3.2.16
$\mathcal{P}_{\leq i}$	The lower i -truncation of an n -proframing.	3.2.29
K_z	The fiber set over a simplex z for a simplicial map $p : K \rightarrow K'$.	3.2.37
$\partial^{\pm} x$	The upper and lower sections of a spacer simplex x .	3.2.39
$\Phi_{\mathcal{P}}(z)$	The fiber category over a simplex z in an n -proframed simplicial complex.	3.2.40
$\text{CollProFrSimpCplx}_n$	The category of collapsible n -proframed simplicial complexes	3.2.45
γ^{\pm}	The lower and upper sections of a spacer cell.	3.3.5
\mathcal{P}^x	The integral proframing of the framed regular subcell determined by x .	3.3.8
$\text{axel} \perp$	The highest frame vectors of an framed regular cell.	3.3.16

Chapter 4

$\ -\ _{\mathbb{M}}$	The mesh realization functor.	§4
$\mathbb{T}-$	The fundamental truss functor.	§4
γ	A framed realization of a manifold M or manifold bundle p .	§4
S^1	The standard framed circle.	4.1.1
\mathbb{R}	The standard framed euclidean space.	4.1.1
γ^{\pm}	The upper and lower realization bounds of a 1-mesh or 1-mesh bundle or family. \rightsquigarrow -index: \triangleright realization bounds \triangleright mesh family.	4.1.15
\mathbb{T}	The fundamental poset functor.	4.1.27
$s \rightarrow r$	A formal entrance path from a stratum s to a stratum r .	4.1.27

$p : (M, f) \rightarrow (B, g)$	A 1-mesh bundle over a base stratification (B, g) .	4.1.28
$\mathbf{fib}(s)$	The fiber 1-mesh over a stratum s .	4.1.34
\mathbb{P}_∞	The fundamental ∞ -category of a stratification f .	4.1.38
\mathbb{P}_1	The fundamental category of a stratification f .	4.1.39
G^*p	The pullback of a mesh bundle.	4.1.57
\bar{p}	The fiberwise compactification of a 1-mesh bundle p . <i>This is analogous, but less general, than \trianglerightcubical compactification of truss bundles.</i>	4.1.58
$p_{\leq i}$	The lower i -truncation of an n -mesh bundle p .	4.1.80
$\text{Tot}G$	The pullback of a mesh bundle map G .	4.1.93
$p _X$	The restriction of an n -mesh bundle p to a substratification X in its base.	4.1.94
Mesh_n	The category of n -meshes.	4.1.95
MeshBun_n	The category of n -mesh bundles.	4.1.95
$\text{Mesh}_n(B, g)$	The category of n -mesh bundles over a base stratification (B, g) .	4.1.95
Mesh_n	The ∞ -category of n -meshes.	4.1.97
$\bar{\text{Mesh}}_n$	The ∞ -category of closed n -meshes and their singular maps.	4.1.97
$\mathring{\text{Mesh}}_n$	The ∞ -category of open n -meshes and their regular maps.	4.1.97
MeshBun_n	The ∞ -category of n -mesh bundles.	4.1.97
$\text{Mesh}_n(B, g)$	The ∞ -category of n -mesh bundles over a base stratification (B, g) .	4.1.97
$\text{Mesh}_n^{\text{bal}}(B, g)$	The ∞ -category of n -mesh bundles over (B, g) with balanced maps.	4.1.97
\mathcal{MBord}_n	The n -mesh bordism category.	4.1.100
N^{hc}	The homotopy coherent nerve functor.	4.2.6
Cyl	The mesh mapping cylinder functor.	4.2.6
coCyl	The mesh mapping cocylinder functor.	4.2.6
$\ -\ _{\text{CM}}$	The cell-to-mesh realization functor.	4.2.7
∇_{MC}	The mesh-to-cell gradient functor.	4.2.7
\dagger	The mesh dualization functor.	4.2.9
\mathbf{c}_s	The regular contour of a regular stratum s .	4.2.29
C_b	The catchment area of an open cell b .	4.2.32
π_b	The radial catchment projection from the closed catchment area to the cell b .	4.2.32
ci	The cubical inclusion map in a cubical compactification.	4.2.50
cr	The cubical retraction map in a cubical compactification.	4.2.50
\bar{p}, \bar{T}	The cubical compactification of a truss bundle p or truss T .	4.2.50
Ci	The inclusion map of a cellular inclusion-retraction pair, from the realization of Y to B .	4.2.68
Cr	The retraction map of a cellular inclusion-retraction pair, from B to the realization of Y .	4.2.68
$\ F\ _{\text{M}}^{\text{crs}}$	The mesh coarsening realization of a coarsening of n -trusses $F : T \rightarrow S$.	4.2.78
$\text{SubDiv}(Y, \mathcal{G}; X, \mathcal{F})$	The space of framed subdivisions between framed regular cell complexes (Y, \mathcal{G}) and (X, \mathcal{F}) .	4.2.91

Chapter 5

(M, f)	Stratified mesh.	§5
$M \rightarrow f$	Mesh refinement of a tame stratification f by a mesh M .	§5
$\ -\ _{\mathbb{M}}$	Stratified mesh realization.	§5
$\mathbb{T}(M, f)$	Fundamental stratified truss of a stratified mesh (M, f) .	§5
ι	A tame embedding.	5.1.4
$f \vee g$	The join of stratifications f and g .	5.2.1
\mathbf{s}	An equivalence class of strata in a join of stratifications.	5.2.5
$M \vee M'$	The join of two n -meshes M and M' .	5.2.10
$p \vee q$	The join of two n -mesh bundles p and q .	5.2.11
FM	The pushforward mesh of a mesh M under a framed homeomorphism F .	5.2.24
$F^{-1}N$	The pullback mesh of a mesh N under a framed homeomorphism F .	5.2.24
$\mathbb{T}(T)$	The fundamental poset of a stratified truss.	5.3.1
\mathbb{T}	The normal form of a stratified truss T .	5.3.60
(Z^\dagger, f^\dagger)	The dual stratification of an n -tame stratification.	5.3.70
X_{\min}	The coarsest cell structure of an n -directed acyclic graph	5.3.82

Appendix A

V	A vector space.	§A
\vec{V}	The associated affine space of a vector space.	A.2.1
\mathcal{V}	An affine space	A.2.1
$\vec{\mathcal{V}}$	The associated vector space of an affine space.	A.2.1
$\langle S \rangle$	The affine hyperplane spanned by a simplex.	A.2.2
Δ^m	The standard geometric m -simplex.	A.2.4
$\hat{\mathcal{V}}$	Affine space of affine vectors in an affine space.	A.2.5

Appendix B

TOP	The category of all topological spaces.	B.1.2
$k\text{Top}$	The category of compactly generated spaces.	B.1.2
Top	The category of compactly generated weakly Hausdorff spaces.	B.1.2
$\text{Map}(-, -)$	The internal hom for compactly generated spaces.	B.1.2
$\text{Spcl } X$	The specialization order of a topological space X .	B.1.4
$\mathbb{T}(f)$	The fundamental preorder of a prestratification (X, f) .	B.1.10
$\mathbb{T}(f)^{\text{op}}$	The exit path preorder of a prestratification (X, f) .	B.1.14
$y <^{\text{cov}} x$	The covering relation in a poset.	B.1.34
$\text{cmpnt}(f)$	The connected component set of a P -structure.	B.1.45
$\text{char}(f)$	The characteristic function of the connected component splitting of a P -structure.	B.1.45
$\text{discr}(f)$	The discrete map of the connected component splitting of a P -structure	B.1.45
$ -\ $	Geometric realization of a poset or poset map.	B.1.51
$\ -\ $	The stratified realization of a poset or poset map.	B.1.52
$\text{str}(x)$	The stratum in $\ P\ $ corresponding to the object $x \in P$.	B.1.52

$g _X$	The restriction of a stratification (Y, g) to a subspace X .	B.2.7
Strat	The category of stratifications and their stratified maps.	B.2.13
<i>Strat</i>	The $k\mathbf{Top}$ -enriched category of stratified spaces and their stratified maps.	B.2.17
\mathcal{Pos}_{ℓ_f}	The $k\mathbf{Top}$ -enriched category of locally finite posets.	B.2.18
\mathcal{Strat}_{ℓ_f}	The $k\mathbf{Top}$ -enriched category of locally finite stratifications.	B.2.20
$(- \times -)$	The topological product functor for stratifications.	B.2.22
$\mathcal{Strat}_{\ell_f}(f, g)_F$	The preimage of F under the fundamental poset map $\mathbb{I} : \mathcal{Strat}_{\ell_f}(f, g) \rightarrow \mathcal{Pos}_{\ell_f}(\mathbb{I}(f), \mathbb{I}(g))$.	B.2.23
$(X, f) \times_{(Z, h)} (Y, g)$	The pullback stratification.	B.2.26
F^*p	The pullback of a stratified bundle p along a stratified map F .	B.2.28
$\overline{\mathbf{cone}}(f)$	The closed cone of a stratification (X, f) .	B.3.1
$\mathbf{cone}(f)$	The open cone of a stratification (X, f) .	B.3.1
$\mathbf{link}(x)$	The link at a point x in a stratification (X, f) . <i>Coincides with the cellular link for regular cell complexes.</i>	B.3.2
$\mathbb{I}_{\infty}f$	The fundamental ∞ -category of a conical stratification f .	B.3.10
$\mathbf{star}(x)$	The cellular star of a cell x in a regular cell complex.	B.3.28
$\mathbf{link}(x)$	The cellular link of a cell x in a regular cell complex. <i>Coincides with the link of regular cell complexes as conical stratifications.</i>	B.3.28
$\mathbf{BSub}(X)$	The barycentric subdivision of a regular cell complex X .	B.3.32
$\mathbf{CSub}_X(x)$	The conical subdivision of a cell x in a regular cell complex X .	B.3.32

INDEX OF TERMS

α

C-labeling (see **l**), \rightsquigarrow 2.2.39
k-partial frame (see **p**), \rightsquigarrow 1.1.33,
 \rightsquigarrow 1.1.34
k-partial proframe (see **p**), \rightsquigarrow 3.2.3
k-stage (see **s**), \rightsquigarrow 2.3.2
m-cell (see **c**), \rightsquigarrow 1.3.17
m-frame (see **f**), \rightsquigarrow 1.1.24
m-proframe (see **p**), \rightsquigarrow 3.2.1
m-simplex (see **s**), \rightsquigarrow 1.1.1
n-DAG (see **d**), \rightsquigarrow 1.3.75
n-directed acyclic graph (see **d**), \rightsquigarrow 1.3.74
n-directed graph (see **d**), \rightsquigarrow 1.3.73
n-embedded frame (see **e**), \rightsquigarrow 1.1.41
n-embedded framed map, \rightsquigarrow 1.1.64
n-embedded proframe (see **e**), \rightsquigarrow 3.2.5
n-framing (see **f**), \rightsquigarrow 1.2.7
n-graph (see **g**), \rightsquigarrow 1.3.73
n-proframing (see **p**), \rightsquigarrow 3.2.25
n-realization (see **r**), \rightsquigarrow 4.1.70
n-tame (see **t**), \rightsquigarrow 5.1.1
n-tame stratified bundle, \rightsquigarrow 5.3.38
n-truss (see **t**), \rightsquigarrow 2.3.1
n-truss block set, \rightsquigarrow 2.3.84
n-truss brace set, \rightsquigarrow 2.3.107
1-framed manifold (see **f**), \rightsquigarrow 4.1.1
1-mesh (see **m**), \rightsquigarrow 4.1.13
1-realization (see **r**), \rightsquigarrow 4.1.3ff
1-truss (see **t**), \rightsquigarrow 2.1.6

a

acyclic *n*-graph, \rightsquigarrow 1.3.74
admissible 1-simplex, \rightsquigarrow 1.2.24
affine cokernel, \rightsquigarrow 1.1.20
affine degeneracy, \rightsquigarrow A.2.10
affine face, \rightsquigarrow 1.1.18, \rightsquigarrow A.2.10
affine frame, \rightsquigarrow A.2.7
affine image, \rightsquigarrow 1.1.19
affine indframe, \rightsquigarrow A.2.7, \rightsquigarrow A.2.11
affine kernel, \rightsquigarrow 1.1.17
affine map, \rightsquigarrow 1.1.22, \rightsquigarrow A.2.1, \rightsquigarrow A.2.3
affine proframe, \rightsquigarrow A.2.7, \rightsquigarrow A.2.12
affine space, \rightsquigarrow A.2.1

affine space of affine vectors, \rightsquigarrow A.2.5
affine trivialization, \rightsquigarrow A.2.7
affine vector functor, \rightsquigarrow A.2.5
affine-linear kernel, \rightsquigarrow A.2.9
almost constructible 1-mesh
bundle, \rightsquigarrow 4.1.47
almost continuous 1-mesh
bundle, \rightsquigarrow 4.1.47
ambient stratified
Hauptvermutung, §5.3.2.2
ambient stratified truss, \rightsquigarrow 5.3.8
ambiently tame stratification, \rightsquigarrow 5.1.3
associated vector space, \rightsquigarrow A.2.1
associated vector space functor, \rightsquigarrow A.2.1
axel vector, \rightsquigarrow 1.3.52

b

balanced *n*-mesh bundle map, \rightsquigarrow 4.1.89
balanced *n*-truss bundle map, \rightsquigarrow 2.3.37
balanced 1-mesh bundle map, \rightsquigarrow 4.1.52
balanced 1-mesh map, \rightsquigarrow 4.1.18
balanced 1-truss bundle map, \rightsquigarrow 2.1.88
balanced 1-truss map, \rightsquigarrow 2.1.17
balanced isomorphism, \rightsquigarrow 2.1.20,
 \rightsquigarrow 2.2.66, \rightsquigarrow 2.3.41
balanced labeled *n*-truss bundle
map, \rightsquigarrow 2.3.37
balanced labeled 1-truss bundle
map, \rightsquigarrow 2.2.62
balanced map, \rightsquigarrow 2.1.17, \rightsquigarrow 2.2.62,
 \rightsquigarrow 2.3.37, \rightsquigarrow 4.1.18, \rightsquigarrow 4.1.89
barycentric subdivision, \rightsquigarrow 1.3.31,
 \rightsquigarrow 1.3.61, \rightsquigarrow B.3.32
base poset, \rightsquigarrow 2.1.74, \rightsquigarrow 2.3.27
base poset of a 1-truss bundle, \rightsquigarrow 2.1.74
base poset of an *n*-truss bundle, \rightsquigarrow 2.3.27
base stratification, \rightsquigarrow B.2.24ff
base-preserving map, \rightsquigarrow 2.1.87, \rightsquigarrow 2.2.61,
 \rightsquigarrow 2.3.36, \rightsquigarrow 4.1.92
base-preserving map of *n*-mesh
bundles, \rightsquigarrow 4.1.92
base-preserving map of 1-truss
bundles, \rightsquigarrow 2.1.87

- base-preserving map of labeled n -truss bundles, \rightsquigarrow 2.3.36
 base-preserving map of labeled 1-truss bundles, \rightsquigarrow 2.2.61
 basepoint forgetting map, \rightsquigarrow A.2.6
 bifunctional relation, \rightsquigarrow 2.1.33
 bifunctionality, \rightsquigarrow 2.1.33
 bimonotone relation, \rightsquigarrow 2.1.32, \rightsquigarrow 2.1.33
 bimonotonicity, \rightsquigarrow 2.1.33
 block complex, \rightsquigarrow 2.3.90
 block nerve functor, \rightsquigarrow 2.3.94
 block nerve of trusses, \rightsquigarrow 2.3.94
 block set, \rightsquigarrow 2.3.86
 boolean profunctor, \rightsquigarrow 2.1.38
 bordism-as-profunctor
 pseudofunctor, \rightsquigarrow 2.2.51
 bottom section, \rightsquigarrow 2.2.27
 boundary degeneracy of truss blocks, \rightsquigarrow 2.3.98
 boundary dislocation, \rightsquigarrow 2.1.48
 boundary divergence, \rightsquigarrow 2.1.48, \rightsquigarrow 4.1.49
 boundary evaporation, \rightsquigarrow 2.1.47, \rightsquigarrow 4.1.48
 boundary of a cell, \rightsquigarrow 1.3.17
 bounded 1-framed realization, \rightsquigarrow 4.1.4, \rightsquigarrow 4.1.14
 bounded 1-mesh, \rightsquigarrow 4.1.14
 brace set, \rightsquigarrow 2.3.109
 building trusses from their blocks, \rightsquigarrow 2.3.95
 bundle isomorphism κ , \rightsquigarrow 4.2.35
- C**
-
- (n, k) -category, \rightsquigarrow B.3.11
 ∞ -category of n -mesh bundles, \rightsquigarrow 4.1.97
 ∞ -category, \rightsquigarrow 4.1.96
 m -cell, \rightsquigarrow 1.3.17
 2-cube cell, §C.1
 collapsible proframed simplicial complex, \rightsquigarrow 3.2.45
 canonical mesh of tame embedding, \rightsquigarrow 5.2.30
 canonical mesh of tame stratification, \rightsquigarrow 5.2.23
 catchment area, \rightsquigarrow 4.2.32
 catchment projection, \rightsquigarrow 4.2.32
 categorical n -mesh bundle, \rightsquigarrow 4.1.81
 categorical n -truss bundle, \rightsquigarrow 2.3.53
 categorical 1-mesh bundle, \rightsquigarrow 4.1.41
 categorical 1-truss bundle, \rightsquigarrow 2.1.85, \rightsquigarrow 2.2.74
 categorical labeled n -truss bundle, \rightsquigarrow 2.3.53
 categorical labeled 1-truss bundle, \rightsquigarrow 2.2.74
 categorical mesh bordism, \rightsquigarrow 4.1.101
 category of n -embedded framed simplices, \rightsquigarrow 1.1.67
 category of n -embedded partially framed simplices, \rightsquigarrow 1.1.73
 category of n -embedded proframed simplices, \rightsquigarrow 3.2.12
 category of n -framed regular cell complexes, \rightsquigarrow 1.3.60
 category of n -framed regular cells, \rightsquigarrow 1.3.60
 category of n -framed simplicial complexes, \rightsquigarrow 1.2.17
 category of n -mesh bundles, \rightsquigarrow 4.1.95
 category of n -mesh bundles over a base stratification, \rightsquigarrow 4.1.95
 category of n -meshes, \rightsquigarrow 4.1.95
 category of n -proframed simplicial complexes, \rightsquigarrow 3.2.28
 category of n -truss block sets, \rightsquigarrow 2.3.85
 category of n -truss blocks, \rightsquigarrow 2.3.78
 category of n -truss brace sets, \rightsquigarrow 2.3.108
 category of n -truss braces, \rightsquigarrow 2.3.105
 category of n -truss bundles, \rightsquigarrow 2.3.38
 category of n -truss bundles over a poset, \rightsquigarrow 2.3.38
 category of n -trusses, \rightsquigarrow 2.3.38
 category of n -trusses and their bordisms, \rightsquigarrow 2.3.21
 category of n -trusses and their coarsenings, \rightsquigarrow 2.3.66
 category of n -trusses and their degeneracies, \rightsquigarrow 2.3.66
 category of 1-truss bundles, \rightsquigarrow 2.1.90
 category of 1-truss bundles and their bordisms, \rightsquigarrow 2.1.97
 category of 1-truss bundles over a base poset, \rightsquigarrow 2.1.90
 category of 1-trusses, \rightsquigarrow 2.1.19
 category of 1-trusses and their bordisms, \rightsquigarrow 2.1.53
 category of 1-trusses and their endpoint-preserving regular maps, \rightsquigarrow 2.1.67
 category of 1-trusses and their endpoint-preserving singular maps, \rightsquigarrow 2.1.67
 category of block complexes, \rightsquigarrow 2.3.92
 category of block sets, \rightsquigarrow 2.3.87

- category of blocks, \rightsquigarrow 2.3.79
- category of boolean profunctors, \rightsquigarrow 2.1.39
- category of brace sets, \rightsquigarrow 2.3.110
- category of braces, \rightsquigarrow 2.3.106
- category of closed n -mesh bundles and their singular maps, \rightsquigarrow 4.1.95
- category of closed n -truss bundles and their singular maps, \rightsquigarrow 2.3.38, \rightsquigarrow 2.3.59
- category of closed 1-truss bundles and their singular maps, \rightsquigarrow 2.1.90
- category of closed 1-trusses and their bordisms, \rightsquigarrow 2.1.53
- category of closed 1-trusses and their singular maps, \rightsquigarrow 2.1.25
- category of collapsible n -framed regular cell complexes, \rightsquigarrow 1.3.60
- category of collapsible n -framed simplicial complexes, \rightsquigarrow 1.2.34
- category of collapsible n -proframed simplicial complexes, \rightsquigarrow 3.2.45
- category of combinatorial regular cell complexes, \rightsquigarrow 1.3.23
- category of compactly generated spaces, \rightsquigarrow B.1.2
- category of compactly generated weakly Hausdorff spaces, \rightsquigarrow B.1.2
- category of geometric regular cell complexes, \rightsquigarrow 1.3.20
- category of labeled n -truss bundles, \rightsquigarrow 2.3.38
- category of labeled n -truss bundles and their bordisms, \rightsquigarrow 2.3.50
- category of labeled n -trusses, \rightsquigarrow 2.3.38
- category of labeled n -trusses and their bordisms, \rightsquigarrow 2.3.20
- category of labeled 1-truss bundles, \rightsquigarrow 2.2.63
- category of labeled 1-truss bundles and their bordisms, \rightsquigarrow 2.2.71
- category of labeled 1-trusses and their bordisms, \rightsquigarrow 2.2.46
- category of open n -mesh bundles and their regular maps, \rightsquigarrow 4.1.95
- category of open n -truss bundles and their regular maps, \rightsquigarrow 2.3.38, \rightsquigarrow 2.3.59
- category of open 1-truss bundles and their regular maps, \rightsquigarrow 2.1.90
- category of open 1-trusses and their bordisms, \rightsquigarrow 2.1.53
- category of open 1-trusses and their regular maps, \rightsquigarrow 2.1.25
- category of ordered simplices, \rightsquigarrow 1.1.2
- category of regular block complexes, \rightsquigarrow 2.3.92
- category of stratifications, \rightsquigarrow B.2.13
- category of topological spaces, \rightsquigarrow B.1.2
- category of unordered simplices, \rightsquigarrow 1.1.3
- cell boundary, \rightsquigarrow 1.3.17
- cell closure, \rightsquigarrow 1.3.17
- cell-to-mesh realization, \rightsquigarrow 4.2.7
- cellulable stratification, \rightsquigarrow 4.1.62, \rightsquigarrow B.3.21, \rightsquigarrow B.3.23
- cellulable stratification regularity, \rightsquigarrow B.3.27
- cellular inclusion-retraction, \rightsquigarrow 4.2.68
- cellular link, \rightsquigarrow B.3.28
- cellular map, \rightsquigarrow 1.3.19, \rightsquigarrow 1.3.22
- cellular map of cellular posets, \rightsquigarrow 1.3.22
- cellular map of regular cell complexes, \rightsquigarrow 1.3.19
- cellular poset, \rightsquigarrow 1.3.13
- cellular star, \rightsquigarrow B.3.28
- cellular stratification, \rightsquigarrow 4.1.61, \rightsquigarrow B.3.20
- cellulation, \rightsquigarrow B.3.22
- central fiber bounds, \rightsquigarrow 3.3.1
- characteristic function, \rightsquigarrow B.1.19
- circular 1-mesh, \rightsquigarrow 4.1.10
- circular 1-truss, \rightsquigarrow 2.1.7
- circular fence, \rightsquigarrow 2.1.2
- circus, \rightsquigarrow 2.1.7
- classification functor, \rightsquigarrow 2.1.100, \rightsquigarrow 2.2.73, \rightsquigarrow 2.3.44, \rightsquigarrow 2.3.52
- classification functor for 1-truss bundles, \rightsquigarrow 2.1.100
- classification functor for categorical 1-truss bundles, \rightsquigarrow 2.2.74
- classification functor for categorical labeled n -truss bundles, \rightsquigarrow 2.3.53
- classification functor for labeled n -truss bundles, \rightsquigarrow 2.3.52
- classification functor for labeled 1-truss bundles, \rightsquigarrow 2.2.73
- classification of tame embeddings, \rightsquigarrow 5.3.33
- classification of tame stratifications, \rightsquigarrow 5.1.23
- classification of tame stratified bundles, \rightsquigarrow 5.3.42
- classifying functor, \rightsquigarrow 2.1.92, \rightsquigarrow 2.2.67
- classifying functor of 1-truss bundles, \rightsquigarrow 2.1.92
- classifying functor of labeled n -truss bundles, \rightsquigarrow 2.3.44

- classifying functor of labeled 1-truss bundles, \rightsquigarrow 2.2.67
- classifying natural transformation, \rightsquigarrow 2.3.49ff
- classifying natural transformation of labeled n -truss bundle bordisms, \rightsquigarrow 2.3.49ff
- closed n -mesh, \rightsquigarrow 4.1.72
- closed n -mesh bundle, \rightsquigarrow 4.1.76
- closed n -mesh map realization, \rightsquigarrow 4.2.48
- closed n -mesh realization, \rightsquigarrow 4.2.47
- closed n -truss, \rightsquigarrow 2.3.3
- closed n -truss bundle, \rightsquigarrow 2.3.28
- closed 1-mesh, \rightsquigarrow 4.1.11
- closed 1-mesh bundle, \rightsquigarrow 4.1.29
- closed 1-mesh bundle realization, \rightsquigarrow 4.2.45
- closed 1-truss, \rightsquigarrow 2.1.23
- closed 1-truss bundle, \rightsquigarrow 2.1.77
- closed catchment area, \rightsquigarrow 4.2.32
- closed cell, \rightsquigarrow 1.3.8
- closed cone, \rightsquigarrow B.3.1
- closure of a cell, \rightsquigarrow 1.3.17
- closure-preserving map of stratifications, \rightsquigarrow 1.3.18
- coarsening, \rightsquigarrow 4.1.20, \rightsquigarrow 4.1.53, \rightsquigarrow 4.1.91, \rightsquigarrow B.2.4
- coarsening of 1-mesh bundles, \rightsquigarrow 4.1.53
- coarsening of n -mesh bundles, \rightsquigarrow 4.1.91
- coarsening of n -meshes, \rightsquigarrow 4.1.91
- coarsening of n -truss bundles, \rightsquigarrow 2.3.65
- coarsening of n -trusses, \rightsquigarrow 2.3.65, \rightsquigarrow 2.3.67
- coarsening of 1-meshes, \rightsquigarrow 4.1.20
- coarsening of 1-trusses, \rightsquigarrow 2.3.63
- coarsening of stratifications, \rightsquigarrow B.2.4
- coarsening of stratified meshes, \rightsquigarrow 5.3.18
- coarsening of stratified trusses, \rightsquigarrow 5.3.11
- coarsest cell structure, \rightsquigarrow 5.3.82
- coarsest cell structure of n -DAGs, \rightsquigarrow 5.3.82
- coarsest refining n -mesh, \rightsquigarrow 5.2.22
- coarsest refining mesh, \rightsquigarrow 5.2.22
- coarsest refining mesh bundle, §5.3.1.5
- codomain of a labeled n -truss bordism, \rightsquigarrow 2.3.13
- cofunctional relation, \rightsquigarrow 2.1.31
- collapse in 1-mesh bundles, \rightsquigarrow 4.1.46
- collapsible framed simplicial complex, \rightsquigarrow 1.2.31
- collapsible proframing, \rightsquigarrow 3.2.43
- collapsible regular cell complex, \rightsquigarrow 1.3.40
- collision in 1-mesh bundles, \rightsquigarrow 4.1.46
- combinatorial regular m -cell, \rightsquigarrow 1.3.17
- combinatorial regular cell complex, \rightsquigarrow 1.3.16, \rightsquigarrow 1.3.23
- combinatorial smooth singularity, §5.4
- combinatorial subdivision, \rightsquigarrow 4.2.89
- combinatorialization of smooth structures, §5.4
- compactification, \rightsquigarrow 4.2.50
- compactified cellulation, \rightsquigarrow 4.2.67
- compactly generated space, \rightsquigarrow B.1.2ff
- compatibility of generalized linear frames and trivializations, \rightsquigarrow A.1.28
- composite n -truss bordism, \rightsquigarrow 2.3.16
- composite 1-truss bordism, \rightsquigarrow 2.1.51
- composite labeled n -truss bordism, \rightsquigarrow 2.3.17
- composite labeled 1-truss bordism, \rightsquigarrow 2.2.42
- composition of n -truss bordisms, \rightsquigarrow 2.3.16
- composition of 1-truss bordisms, \rightsquigarrow 2.1.51
- composition of 1-truss bundle bordisms, \rightsquigarrow 2.1.96
- composition of labeled n -truss bordisms, \rightsquigarrow 2.3.17
- composition of labeled n -truss bundle bordisms, \rightsquigarrow 2.3.49
- composition of labeled 1-truss bordisms, \rightsquigarrow 2.2.42
- composition of labeled 1-truss bundle bordisms, \rightsquigarrow 2.2.70
- cone, \rightsquigarrow B.3.1
- cone of cells, §C.2
- cone stratum of mesh brace, \rightsquigarrow 4.2.94
- cone stratum of tubular neighborhood, \rightsquigarrow B.3.2
- conical stratification, \rightsquigarrow B.3.2
- conical subdivision, \rightsquigarrow B.3.32
- connected component set, \rightsquigarrow B.1.16
- connected component splitting, \rightsquigarrow 5.3.6, \rightsquigarrow B.1.45
- connected-quotient map, \rightsquigarrow B.1.37
- connected-quotient map between posets, \rightsquigarrow 5.3.3, \rightsquigarrow B.1.38
- constructibility, \rightsquigarrow 4.1.28, \rightsquigarrow 4.1.41
- constructibility condition in 1-mesh bundles, \rightsquigarrow 4.1.28
- constructible bundle, \rightsquigarrow 4.1.28ff, \rightsquigarrow B.2.29
- constructible stratified bundle, \rightsquigarrow B.2.29
- constructible substratification, \rightsquigarrow B.2.8
- continuity condition in 1-mesh bundles, \rightsquigarrow 4.1.28

contractibility of realizations, \rightsquigarrow 4.1.79
 convex combination of poset
 objects, \rightsquigarrow B.1.51
 core cell, \rightsquigarrow B.3.28
 corepresentable boolean
 profunctor, \rightsquigarrow 2.1.42
 cover, \rightsquigarrow B.1.34
 covering relation, \rightsquigarrow B.1.34
 creation in 1-mesh bundles, \rightsquigarrow 4.1.46
 critical refinement of a tame
 tangle, \rightsquigarrow 5.4.25
 critical strata of a tame tangle, \rightsquigarrow 5.4.25
 cubical compactification, \rightsquigarrow 4.2.50
 cubical compactification for truss bundle
 maps, \rightsquigarrow 4.2.56
 cubical compactification of n -truss
 bundles, \rightsquigarrow 4.2.65
 cubical compactification of 1-truss
 bundles, \rightsquigarrow 4.2.64
 cubical compactification of
 1-trusses, \rightsquigarrow 4.2.63
 cubical inclusion, \rightsquigarrow 4.2.50
 cubical retraction, \rightsquigarrow 4.2.50
 cubically compactified
 coarsening, \rightsquigarrow 4.2.77

d

n -DAG, \rightsquigarrow 1.3.75
 n -directed acyclic graph, \rightsquigarrow 1.3.74
 n -directed graph, \rightsquigarrow 1.3.73
 degeneracy, \rightsquigarrow 4.1.20, \rightsquigarrow 4.1.53, \rightsquigarrow 4.1.91
 degeneracy in a block set, \rightsquigarrow 2.3.88
 degeneracy of 1-mesh bundles, \rightsquigarrow 4.1.53
 degeneracy of n -mesh bundles, \rightsquigarrow 4.1.91
 degeneracy of n -meshes, \rightsquigarrow 4.1.91
 degeneracy of n -truss bundles, \rightsquigarrow 2.3.65
 degeneracy of n -trusses, \rightsquigarrow 2.3.65
 degeneracy of 1-meshes, \rightsquigarrow 4.1.20
 degeneracy of 1-trusses, \rightsquigarrow 2.3.63
 degeneracy of simplices, \rightsquigarrow 1.1.5
 degenerate vector of a simplex, \rightsquigarrow 1.1.11
 dense stratum of mesh block, \rightsquigarrow 4.2.81
 diagram, \rightsquigarrow 5.4.13
 diagram isotopy, \rightsquigarrow 5.4.17
 dimension functor, \rightsquigarrow 2.1.4
 dimension functor of fences, \rightsquigarrow 2.1.4
 dimension map, \rightsquigarrow 2.1.10, \rightsquigarrow 2.1.74
 dimension map of a 1-truss, \rightsquigarrow 2.1.10
 dimension map of a 1-truss
 bundle, \rightsquigarrow 2.1.74

diposet, \rightsquigarrow 2.1.15
 diposet map, \rightsquigarrow 2.1.15
 directed spine, \rightsquigarrow 1.1.13, \rightsquigarrow 1.1.14
 discrete map, \rightsquigarrow B.1.44
 discrete prestratification, \rightsquigarrow B.1.17
 domain of a labeled n -truss
 bordism, \rightsquigarrow 2.3.13
 double suspension theorem, \rightsquigarrow B.3.29
 dual n -truss, \rightsquigarrow 2.3.57
 dual n -truss bundle, \rightsquigarrow 2.3.57
 dual n -truss bundle map, \rightsquigarrow 2.3.57
 dual 1-truss, \rightsquigarrow 2.1.26
 dual 1-truss bordism, \rightsquigarrow 2.1.57
 dual 1-truss map, \rightsquigarrow 2.1.26
 dual framed regular cell
 complex, \rightsquigarrow 4.2.97
 dual labeled truss bundle, \rightsquigarrow 2.2.78,
 \rightsquigarrow 2.3.57
 dual labeled truss bundle
 bordism, \rightsquigarrow 2.2.79, \rightsquigarrow 2.3.58
 dual labeled truss bundle map, \rightsquigarrow 2.2.78,
 \rightsquigarrow 2.3.57
 dual stratification, \rightsquigarrow 5.3.70
 dual stratified truss, \rightsquigarrow 5.3.70
 dual truss, \rightsquigarrow 2.1.26
 dual truss bordism, \rightsquigarrow 2.1.57, \rightsquigarrow 2.3.58
 dual truss bundle, \rightsquigarrow 2.1.107, \rightsquigarrow 2.3.57
 dual truss bundle bordism, \rightsquigarrow 2.1.108,
 \rightsquigarrow 2.3.58
 dual truss bundle map, \rightsquigarrow 2.1.107,
 \rightsquigarrow 2.3.57
 dual truss map, \rightsquigarrow 2.1.26
 dualization functor, \rightsquigarrow 2.1.26, \rightsquigarrow 2.1.57,
 \rightsquigarrow 2.1.107, \rightsquigarrow 2.1.108, \rightsquigarrow 2.2.78,
 \rightsquigarrow 2.2.79, \rightsquigarrow 2.3.57
 dualization functor of labeled truss
 bundle bordisms, \rightsquigarrow 2.2.79, \rightsquigarrow 2.3.58
 dualization functor of labeled truss
 bundles, \rightsquigarrow 2.2.78, \rightsquigarrow 2.3.57
 dualization functor of labeled
 trusses, \rightsquigarrow 2.3.57
 dualization functor of truss
 bordisms, \rightsquigarrow 2.1.57
 dualization functor of truss bundle
 bordisms, \rightsquigarrow 2.1.108
 dualization functor of truss
 bundles, \rightsquigarrow 2.1.107
 dualization functor of trusses, \rightsquigarrow 2.1.26

e

n-embedded *k*-partial frame on an
m-simplex, ↗1.1.46
n-embedded *k*-partial proframe on a
simplex, ↗3.2.7
n-embedded frame of the
m-simplex, ↗1.1.41
n-embedded proframe on an
m-simplex, ↗3.2.5
n-embedded proframed map, ↗3.2.11
n-embedded proframed
realization, ↗3.2.9
n-embedded proframed
simplices, ↗3.2.12
n-embedded subproframed
map, ↗3.2.13
elementary collapse, ↗1.2.25
embedded frame on a simplex, ↗1.1.41
embedded frame on the standard
simplex, ↗1.1.40
embedded framed simplex, ↗1.1.40,
↗1.1.41
embedded partial frame on a
simplex, ↗1.1.46
embedded proframe on a
simplex, ↗3.2.5
embedding brace, ↗2.3.104
embedding of *n*-truss bundles, ↗2.3.65
embedding of *n*-trusses, ↗2.3.65
embedding of 1-trusses, ↗2.3.61
entrance path, ↗4.1.27ff, ↗B.1.5
entrance path convention, ↗B.1.15
essentially injective functor, ↗4.2.22
exit path, ↗B.1.14
exit path convention, ↗B.1.15
exit path preorder, ↗B.1.14

f

\mathcal{S} -filtration, ↗B.1.49
m-frame on a simplex, ↗1.1.24
n-framed boundary complex, ↗5.3.82ff
n-framed map, ↗4.1.86, ↗5.1.15
n-framed realization of *n*-mesh
bundles, ↗4.1.77
n-framed realization, ↗1.2.14, ↗1.3.37,
↗4.1.70
n-framed stratified map, ↗5.1.15
n-framing of combinatorial regular cell
complexes, ↗1.3.34

n-framing of simplicial
complexes, ↗1.2.7
n-framing, ↗1.2.7, ↗1.3.34
1-framed circular realization, ↗4.1.3
1-framed linear realization, ↗4.1.3
1-framed map of 1-realized
manifolds, ↗4.1.8
1-framed map, ↗4.1.7, ↗4.1.8
1-framed realization of families of
manifolds, ↗4.1.23
face block, ↗2.3.81
face in a block set, ↗2.3.88
face of *n*-truss bundles, ↗2.3.65
face of *n*-trusses, ↗2.3.65
face of 1-trusses, ↗2.3.61
face of simplices, ↗1.1.5
face order, ↗2.1.10, ↗2.1.74, ↗2.3.2,
↗2.3.27
face order of a 1-truss, ↗2.1.10
face order of a truss bundle, ↗2.1.74,
↗2.3.27
face poset, ↗1.3.10
face poset functor, ↗1.3.30
face poset of a simplicial
complex, ↗1.3.30
facet, ↗1.3.10ff, ↗3.3.20
family of 1-meshes, ↗4.1.24
fence, ↗2.1.1
fiber 1-mesh, ↗4.1.34
fiber category, ↗2.2.36, ↗3.2.40
fiber category in a 1-truss
bundle, ↗2.2.36
fiber category in a proframing, ↗3.2.40
fiber morphism, ↗2.2.21
fiber set in a simplicial map, ↗3.2.37
fiber transition functor, ↗2.2.37
fiberwise compactification of 1-mesh
bundles, ↗4.1.58
finite fence, ↗2.1.2
finite stratification, ↗B.1.18
finitely continuous map, ↗B.1.20
flow existence, ↗1.2.31
flow uniqueness, ↗1.2.31
formal entrance path, ↗4.1.27, ↗B.1.6
formal entrance path relation, ↗B.1.7
frame *k*-vector, ↗1.2.11
frame label, ↗1.2.11
frame on a simplex, ↗1.1.24
frame on the standard simplex, ↗1.1.23
frame order, ↗2.1.10, ↗2.1.74, ↗2.3.27
frame order of a 1-truss, ↗2.1.10
frame order of a truss bundle, ↗2.1.74,
↗2.3.27

- frame restriction, \rightsquigarrow 1.1.53, \rightsquigarrow 1.1.55,
 \rightsquigarrow 1.1.57, \rightsquigarrow 1.1.59, \rightsquigarrow 1.1.61,
 \rightsquigarrow 1.2.19
- frame restriction of partial simplicial
frames, \rightsquigarrow 1.1.61
- frame restriction to a simplicial
face, \rightsquigarrow 1.1.53, \rightsquigarrow 1.1.59
- frame restriction to a simplicial
vector, \rightsquigarrow 1.1.55
- frame restriction to a standard simplicial
face, \rightsquigarrow 1.1.57
- framed cellular map, \rightsquigarrow 1.3.56
- framed coarsening, \rightsquigarrow 5.3.78
- framed collapsible regular cell
complex, \rightsquigarrow 1.3.40
- framed collapsible simplicial
complex, \rightsquigarrow 1.2.31
- framed conical tame embeddings, \rightsquigarrow 5.4.2
- framed conical tame
stratification, \rightsquigarrow 5.4.1
- framed conicality, \rightsquigarrow 5.4.4
- framed degeneracy, \rightsquigarrow 1.1.66
- framed elementary collapse, \rightsquigarrow 1.2.28,
 \rightsquigarrow 1.2.29
- framed face, \rightsquigarrow 1.1.65
- framed face poset, \rightsquigarrow 1.3.62
- framed face poset functor, \rightsquigarrow 1.3.63
- framed Hauptvermutung, \rightsquigarrow 5.1.27,
§5.3.2.2
- framed homeomorphism, \rightsquigarrow 5.3.77
- framed map, \rightsquigarrow 1.1.64, \rightsquigarrow 1.1.72, \rightsquigarrow 1.2.16,
 \rightsquigarrow 1.3.56, \rightsquigarrow 4.1.8, \rightsquigarrow 4.1.86, \rightsquigarrow 5.1.15
- framed map of embedded partially
framed simplices, \rightsquigarrow 1.1.72
- framed map of framed regular cell
complexes, \rightsquigarrow 1.3.56
- framed map of framed
simplices, \rightsquigarrow 1.1.64
- framed map of realizations, \rightsquigarrow 4.1.87
- framed map of standard 1-framed
targets, \rightsquigarrow 4.1.7
- framed map of tame
embeddings, \rightsquigarrow 5.1.16
- framed map of tame
stratifications, \rightsquigarrow 5.1.15
- framed map over a base map, \rightsquigarrow 4.1.86
- framed progressive regular cell
complex, \rightsquigarrow 1.3.40
- framed progressive simplicial
complex, \rightsquigarrow 1.2.37
- framed realization, \rightsquigarrow 1.1.29, \rightsquigarrow 1.1.37,
 \rightsquigarrow 1.1.44, \rightsquigarrow 1.1.50, \rightsquigarrow 1.2.14,
 \rightsquigarrow 1.3.37, \rightsquigarrow 4.1.3, \rightsquigarrow 4.1.70
- framed realization of embedded framed
simplices, \rightsquigarrow 1.1.44
- framed realization of embedded partially
framed simplices, \rightsquigarrow 1.1.50
- framed realization of framed regular cell
complexes, \rightsquigarrow 1.3.37
- framed realization of framed
simplices, \rightsquigarrow 1.1.29
- framed realization of framed simplicial
complexes, \rightsquigarrow 1.2.14
- framed realization of manifolds, \rightsquigarrow 4.1.3
- framed realization of meshes, \rightsquigarrow 4.1.70
- framed realization of partially framed
simplices, \rightsquigarrow 1.1.37
- framed regular cell, \rightsquigarrow 1.3.34
- framed regular cell complex, \rightsquigarrow 1.3.34
- framed regular PL cell, \rightsquigarrow 1.3.72
- framed simplex, \rightsquigarrow 1.1.23, \rightsquigarrow 1.1.24,
 \rightsquigarrow 1.1.33, \rightsquigarrow 1.1.34, \rightsquigarrow 1.1.40
- framed simplicial complex, \rightsquigarrow 1.2.7
- framed simplicial map, \rightsquigarrow 1.2.16
- framed stratified
homeomorphism, \rightsquigarrow 5.1.17
- framed stratified map, \rightsquigarrow 5.1.15
- framed subdivision of framed regular cell
complexes, \rightsquigarrow 4.2.87
- framing of combinatorial regular cell
complexes, \rightsquigarrow 1.3.34
- framing of simplicial complexes, \rightsquigarrow 1.2.7
- frontier-constructible
stratification, \rightsquigarrow 4.1.36, \rightsquigarrow B.1.25
- functional relation, \rightsquigarrow 2.1.31
- functorial relation, \rightsquigarrow 2.1.30, \rightsquigarrow 2.3.14
- functorial relation of preorders, \rightsquigarrow 2.1.30
- fundamental ∞ -category, \rightsquigarrow B.3.10,
 \rightsquigarrow B.3.34
- fundamental ∞ -category for cellulable
stratifications, \rightsquigarrow B.3.34
- fundamental ∞ -category of a
stratification, \rightsquigarrow 4.1.38
- fundamental 1-category, \rightsquigarrow B.3.14
- fundamental 1-truss bundle, \rightsquigarrow 4.2.11
- fundamental category, \rightsquigarrow 4.1.38, \rightsquigarrow 4.1.39
- fundamental category of a
stratification, \rightsquigarrow 4.1.39
- fundamental higher category of a
stratification, \rightsquigarrow 4.1.38
- fundamental poset, \rightsquigarrow 1.3.10, \rightsquigarrow 4.1.27,
 \rightsquigarrow B.1.10
- fundamental poset ∞ -functor, \rightsquigarrow B.2.20
- fundamental poset functor, \rightsquigarrow B.2.15
- fundamental poset of a regular cell
complex, \rightsquigarrow 1.3.10

fundamental poset of a
 stratification, \rightsquigarrow 4.1.27
 fundamental poset of a stratified
 truss, \rightsquigarrow 5.3.1
 fundamental poset truncation, \rightsquigarrow B.3.13
 fundamental preorder, \rightsquigarrow B.1.10
 fundamental stratified truss, \rightsquigarrow 5.3.22
 fundamental stratified truss
 map, \rightsquigarrow 5.3.24
 fundamental truss bundle, \rightsquigarrow 4.2.12
 fundamental truss bundle map, \rightsquigarrow 4.2.13
 fundamental truss functor, \rightsquigarrow 4.2.14

g

n -gradient framing functor, \rightsquigarrow 3.2.32
 n -graph, \rightsquigarrow 1.3.73
 2-globe cell, §C.1
 generalized orthonormal
 frame, \rightsquigarrow A.2.10ff
 generating arrow, \rightsquigarrow 2.1.79, \rightsquigarrow 2.3.30
 generating arrow of 1-truss
 bundles, \rightsquigarrow 2.1.79
 generating arrows of n -truss
 bundles, \rightsquigarrow 2.3.30
 geometric m -simplex, \rightsquigarrow A.2.4
 geometric realization, \rightsquigarrow B.1.51
 geometric realization of a
 simplex, \rightsquigarrow A.2.2
 geometric realization of posets, \rightsquigarrow 1.3.3,
 \rightsquigarrow B.1.51
 geometric regular cell complex, \rightsquigarrow 1.3.20
 geometric simplex, \rightsquigarrow 1.1.27
 gradient cell complex of closed
 n -trusses, \rightsquigarrow 3.3.17
 gradient cell functor, \rightsquigarrow 3.3.17ff
 gradient cellular map of singular truss
 maps, \rightsquigarrow 3.3.18
 gradient frame, \rightsquigarrow 3.2.15
 gradient framed map of proframed
 maps, \rightsquigarrow 3.2.21, \rightsquigarrow 3.2.31
 gradient framing, \rightsquigarrow 3.2.30
 gradient framing functor, \rightsquigarrow 3.2.32
 gradient functor, \rightsquigarrow 3.2.32

h

half-open 1-truss, \rightsquigarrow 2.1.23
 Hauptvermutung, \rightsquigarrow 5.3.53, §5.3.2.2
 highest frame number, \rightsquigarrow 1.2.26

highest frame vector, \rightsquigarrow 1.2.26, \rightsquigarrow 1.3.52
 highest frame vectors of framed regular
 cells, \rightsquigarrow 1.3.52
 homology sphere, \rightsquigarrow B.3.29
 homotopical category, \rightsquigarrow B.3.34
 homotopical poset, \rightsquigarrow B.3.34
 homotopy coherent nerve, \rightsquigarrow 4.2.6

i

image refinement of simplicial
 map, \rightsquigarrow 5.3.48
 indiscrete stratification, \rightsquigarrow B.1.17
 induced indframe, \rightsquigarrow A.1.27
 induced proframe, \rightsquigarrow A.1.27
 infinite stratification, \rightsquigarrow B.1.18
 initial n -truss, \rightsquigarrow 2.3.22
 integral collapsible proframing, \rightsquigarrow 3.2.47
 integral proframe, \rightsquigarrow 3.2.16
 integral proframed cell, \rightsquigarrow 3.3.12
 integral proframed cell complex, \rightsquigarrow 3.3.14
 integral proframed map, \rightsquigarrow 3.2.22
 integral proframing, \rightsquigarrow 3.2.33
 integral proframing functor, \rightsquigarrow 3.2.49
 integration functor, \rightsquigarrow 3.2.49
 interior degeneracy of truss
 blocks, \rightsquigarrow 2.3.98
 interior evaporation, \rightsquigarrow 2.1.47
 isobordism, \rightsquigarrow 2.1.55, \rightsquigarrow 2.1.98, \rightsquigarrow 2.2.72,
 \rightsquigarrow 2.3.51
 isobordism of n -truss bundles, \rightsquigarrow 2.3.51
 isotopy of manifold diagrams, \rightsquigarrow 5.4.17
 iterated labeled 1-truss bordism
 functor, \rightsquigarrow 2.3.23

j

join of mesh bundles, \rightsquigarrow 5.2.11
 join of meshes, \rightsquigarrow 5.2.10
 join of stratifications, \rightsquigarrow 5.2.1
 join of stratified maps, \rightsquigarrow 5.2.8
 jump morphism, \rightsquigarrow 2.2.17

k

kernel of simplicial
 degeneracies, \rightsquigarrow 1.1.16

I

P-labeling of a stratification, \rightsquigarrow B.1.42
 C-labeled n -truss bordism, \rightsquigarrow 2.3.11
 C-labeled n -truss bundle, \rightsquigarrow 2.3.31
 C-labeled n -truss, \rightsquigarrow 2.3.6
 C-labeled 1-truss bordism, \rightsquigarrow 2.2.40
 C-labeled 1-truss bundle, \rightsquigarrow 2.2.57
 C-labeled 1-truss, \rightsquigarrow 2.2.39
 C-labeling of a stratification, \rightsquigarrow B.1.42
 label category functor, \rightsquigarrow 2.2.60ff,
 \rightsquigarrow 2.3.32
 label coarsening of stratified
 trusses, \rightsquigarrow 5.3.11
 label-forgetting functor, \rightsquigarrow 2.2.49
 label-preserving map, \rightsquigarrow 2.2.61, \rightsquigarrow 2.3.36
 label-preserving map of labeled n -truss
 bundles, \rightsquigarrow 2.3.36
 label-preserving map of labeled 1-truss
 bundles, \rightsquigarrow 2.2.61
 labeled n -truss, \rightsquigarrow 2.3.6
 labeled n -truss bordism, \rightsquigarrow 2.3.11
 labeled n -truss bundle, \rightsquigarrow 2.3.31
 labeled n -truss bundle bordism, \rightsquigarrow 2.3.49
 labeled 1-truss, \rightsquigarrow 2.2.39
 labeled 1-truss bordism, \rightsquigarrow 2.2.40
 labeled 1-truss bordism functor, \rightsquigarrow 2.2.50
 labeled 1-truss bundle, \rightsquigarrow 2.2.57
 labeled 1-truss bundle bordism, \rightsquigarrow 2.2.70
 labeled 1-truss isobordism, \rightsquigarrow 2.2.72
 labeling functor, \rightsquigarrow 2.2.39, \rightsquigarrow 2.2.40,
 \rightsquigarrow 2.2.57, \rightsquigarrow 2.3.6, \rightsquigarrow 2.3.11, \rightsquigarrow 2.3.31
 labeling functor of a labeled
 n -truss, \rightsquigarrow 2.3.6
 labeling functor of a labeled n -truss
 bordism, \rightsquigarrow 2.3.11
 labeling functor of a labeled n -truss
 bundle, \rightsquigarrow 2.3.31
 labeling functor of a labeled
 1-truss, \rightsquigarrow 2.2.39
 labeling functor of a labeled 1-truss
 bordism, \rightsquigarrow 2.2.40
 labeling functor of a labeled 1-truss
 bundle, \rightsquigarrow 2.2.57
 labeling structure of
 stratification, \rightsquigarrow B.1.42
 left-closed right-open 1-truss, \rightsquigarrow 2.1.23
 left-open right-closed 1-truss, \rightsquigarrow 2.1.23
 linear k -partial frame, \rightsquigarrow A.1.17
 linear k -partial indframe, \rightsquigarrow A.1.24
 linear k -partial proframe, \rightsquigarrow A.1.25
 linear k -partial trivialization, \rightsquigarrow A.1.16

linear n -embedded k -partial
 frame, \rightsquigarrow A.1.23
 linear n -embedded k -partial
 indframe, \rightsquigarrow A.1.24
 linear n -embedded k -partial
 proframe, \rightsquigarrow A.1.25
 linear n -embedded k -partial
 trivialization, \rightsquigarrow A.1.22
 linear n -embedded frame, \rightsquigarrow A.1.20
 linear n -embedded indframe, \rightsquigarrow A.1.24
 linear n -embedded proframe, \rightsquigarrow A.1.25
 linear n -embedded
 trivialization, \rightsquigarrow A.1.19
 linear 1-mesh, \rightsquigarrow 4.1.10, \rightsquigarrow 4.1.13
 linear 1-truss, \rightsquigarrow 2.1.7, \rightsquigarrow 2.1.10
 linear fence, \rightsquigarrow 2.1.2
 linear frame, \rightsquigarrow A.1.2
 linear indframe, \rightsquigarrow A.1.3
 linear mesh, \rightsquigarrow 5.3.51
 linear proframe, \rightsquigarrow A.1.4
 linear realization of simplicial
 complex, \rightsquigarrow 5.3.45
 linear simplicial complex, \rightsquigarrow 3.2.44
 linear trivialization, \rightsquigarrow A.1.1
 link, \rightsquigarrow B.3.2, \rightsquigarrow B.3.28
 link in a conical stratification, \rightsquigarrow B.3.2
 link in a regular cell complex, \rightsquigarrow B.3.28
 locally finite poset, \rightsquigarrow B.1.23
 locally finite stratification, \rightsquigarrow B.1.22
 lower central section cell, \rightsquigarrow 3.3.7
 lower endpoint, \rightsquigarrow 2.1.22
 lower endpoint of 1-trusses, \rightsquigarrow 2.1.22
 lower fiber bound, \rightsquigarrow 5.2.17
 lower realization bound, \rightsquigarrow 4.1.15,
 \rightsquigarrow 4.1.25
 lower section, \rightsquigarrow 3.2.39, \rightsquigarrow 3.3.5
 lower section of spacer cells, \rightsquigarrow 3.3.5
 lower section of spacer
 simplices, \rightsquigarrow 3.2.39
 lower truncation of truss
 bundles, \rightsquigarrow 2.3.43

m

n -mesh m -block, \rightsquigarrow 4.2.81
 n -mesh m -brace, \rightsquigarrow 4.2.94
 n -mesh m -cell, \rightsquigarrow 5.3.20
 n -mesh m -singularity, \rightsquigarrow 5.3.20
 n -mesh bordism category, \rightsquigarrow 4.1.100
 n -mesh bundle join, \rightsquigarrow 5.2.11
 n -mesh bundle map realization, \rightsquigarrow 4.2.72
 n -mesh bundle map, \rightsquigarrow 4.1.84

- n*-mesh bundle realization
 - functor, \rightsquigarrow 4.2.73
 - n*-mesh bundle realization, \rightsquigarrow 4.2.71
 - n*-mesh bundle, \rightsquigarrow 4.1.76
 - n*-mesh join, \rightsquigarrow 5.2.10
 - n*-mesh map, \rightsquigarrow 4.1.84
 - n*-mesh realization functor, \rightsquigarrow 4.2.60
 - n*-mesh realization, \rightsquigarrow 4.2.52
 - n*-mesh, \rightsquigarrow 4.1.69
 - 1-mesh (linear), \rightsquigarrow 4.1.13
 - 1-mesh bundle map, \rightsquigarrow 4.1.51
 - 1-mesh bundle, \rightsquigarrow 4.1.28
 - 1-mesh map, \rightsquigarrow 4.1.17
 - 1-mesh, \rightsquigarrow 4.1.9, \rightsquigarrow 4.1.13
 - manifold, \rightsquigarrow 4.1.2
 - manifold *n*-diagram, \rightsquigarrow 5.4.13
 - manifold *n*-diagram isotopy, \rightsquigarrow 5.4.17
 - manifold diagram, §5.4, \rightsquigarrow 5.4.13
 - map of 1-mesh bundles, \rightsquigarrow 4.1.51
 - map of *n*-mesh bundles, \rightsquigarrow 4.1.84
 - map of *n*-meshes, \rightsquigarrow 4.1.84
 - map of *n*-truss bundles, \rightsquigarrow 2.3.33
 - map of *n*-trusses, \rightsquigarrow 2.3.35
 - map of 1-meshes, \rightsquigarrow 4.1.17
 - map of 1-truss bundles, \rightsquigarrow 2.1.87
 - map of 1-trusses, \rightsquigarrow 2.1.16
 - map of labeled *n*-truss bundles, \rightsquigarrow 2.3.32
 - map of labeled *n*-trusses, \rightsquigarrow 2.3.34
 - map of labeled 1-truss bundles, \rightsquigarrow 2.2.60
 - map of regular cell complexes, \rightsquigarrow 1.3.11
 - map of stratifications, \rightsquigarrow B.2.1
 - map of stratified meshes, \rightsquigarrow 5.3.17
 - map of stratified trusses, \rightsquigarrow 5.3.10
 - mapping cocylinder of 1-mesh
 - maps, \rightsquigarrow 4.1.35, \rightsquigarrow 4.2.6
 - mapping cocylinder of 1-truss
 - maps, \rightsquigarrow 2.1.68
 - mapping cylinder of 1-mesh
 - maps, \rightsquigarrow 4.1.35, \rightsquigarrow 4.2.6
 - mapping cylinder of 1-truss
 - maps, \rightsquigarrow 2.1.68
 - mesh, \rightsquigarrow 4.1.9, \rightsquigarrow 4.1.69
 - mesh block, \rightsquigarrow 4.2.81
 - mesh brace, \rightsquigarrow 4.2.94
 - mesh bundle join, \rightsquigarrow 5.2.11
 - mesh bundle map realization, \rightsquigarrow 4.2.72
 - mesh bundle realization, §4.2.5, \rightsquigarrow 4.2.71
 - mesh bundle realization functor, §4.2.5, \rightsquigarrow 4.2.73
 - mesh cell, \rightsquigarrow 5.3.20
 - mesh coarsening, \rightsquigarrow 5.3.18
 - mesh coarsening of stratified
 - meshes, \rightsquigarrow 5.3.18
 - mesh coarsening realization of closed
 - truss coarsenings, \rightsquigarrow 4.2.76
 - mesh coarsening realization of truss
 - coarsenings, \rightsquigarrow 4.2.78
 - mesh family, \rightsquigarrow 4.1.24
 - mesh join, \rightsquigarrow 5.2.10
 - mesh map, \rightsquigarrow 4.1.17
 - mesh map realization of truss
 - maps, \rightsquigarrow 4.2.59
 - mesh realization, §4.2.5, \rightsquigarrow 4.2.52
 - mesh realization functor, §4.2.5, \rightsquigarrow 4.2.60
 - mesh refinement, \rightsquigarrow 5.1.1
 - mesh singularity, \rightsquigarrow 5.3.20
 - mesh-to-cell gradient, \rightsquigarrow 4.2.7
 - minimal coarsest refining manifold
 - diagram, \rightsquigarrow 5.4.24
 - minimal coarsest refining mesh, \rightsquigarrow 5.2.28
 - mixed regular and singular
 - section, \rightsquigarrow 2.2.12
- n**
-
- n*-fold iterated labeled 1-truss bordism
 - functor, \rightsquigarrow 2.3.23
 - negative standard component of
 - euclidean space, \rightsquigarrow 1.1.28
 - nerve of posets, \rightsquigarrow 1.3.3
 - non-integrable framing, \rightsquigarrow 3.2.35
 - nondegenerate block of a block
 - set, \rightsquigarrow 2.3.89
 - nondegenerate vector of a
 - simplex, \rightsquigarrow 1.1.11
 - normal form of stratified truss
 - bundle, \rightsquigarrow 5.3.63
 - normal form of stratified
 - trusses, \rightsquigarrow 5.3.60
 - normalized labeled truss
 - bundle, \rightsquigarrow 5.3.40
 - normalized stratified truss, \rightsquigarrow 5.1.22
 - normalized stratified truss
 - bundle, §5.3.1.5, \rightsquigarrow 5.3.40, \rightsquigarrow 5.3.42
 - numeral, \rightsquigarrow 1.1.10
 - numeral set, \rightsquigarrow 1.1.10
- o**
-
- open *n*-mesh, \rightsquigarrow 4.1.72
 - open *n*-mesh bundle, \rightsquigarrow 4.1.76
 - open *n*-truss, \rightsquigarrow 2.3.3
 - open *n*-truss bundle, \rightsquigarrow 2.3.28

open 1-mesh, \rightsquigarrow 4.1.11
 open 1-mesh bundle, \rightsquigarrow 4.1.29
 open 1-truss, \rightsquigarrow 2.1.23
 open 1-truss bundle, \rightsquigarrow 2.1.77
 open cell, \rightsquigarrow 1.3.8
 open characteristic function, \rightsquigarrow B.2.10
 open cone, \rightsquigarrow B.3.1
 ordered m -simplex, \rightsquigarrow 1.1.1
 ordered simplex, \rightsquigarrow 1.1.1
 ordered simplicial complex, \rightsquigarrow 1.2.3
 ordered simplicial complex associated to
 a cellular poset, \rightsquigarrow 1.3.27
 oriented indframe, \rightsquigarrow A.1.8
 oriented proframe, \rightsquigarrow A.1.9
 orthoequivalence, \rightsquigarrow A.1.13, \rightsquigarrow A.1.29
 orthoequivalent trivializations, \rightsquigarrow A.1.29

P

$(\infty, 1)$ -poset, \rightsquigarrow 4.2.17ff
 $(\infty, 2)$ -poset, \rightsquigarrow 4.2.17ff
 k -partial frame on a simplex, \rightsquigarrow 1.1.34
 k -partial proframe on a simplex, \rightsquigarrow 3.2.3
 n -proframed simplicial complex, \rightsquigarrow 3.2.25
 n -proframing, \rightsquigarrow 3.2.25
 2-poset, \rightsquigarrow 4.2.17ff
 partial frame on the standard
 simplex, \rightsquigarrow 1.1.33
 pairwise locally path-connected
 stratification, \rightsquigarrow 4.1.36, \rightsquigarrow B.1.30
 partial n -framing, \rightsquigarrow 1.2.21
 partial frame, \rightsquigarrow 1.1.33, \rightsquigarrow 1.1.34
 partial proframe, \rightsquigarrow 3.2.3
 path-dependent constructibility, \rightsquigarrow 4.1.41
 PL cellular poset, \rightsquigarrow 1.3.32
 point divergence, \rightsquigarrow 2.1.47
 polyhedral stratification, \rightsquigarrow 5.3.46
 polyhedron, \rightsquigarrow 5.3.45
 poset structure on a space, \rightsquigarrow B.1.33
 posetal n -mesh bundle, \rightsquigarrow 4.1.81
 posetal n -truss bundle, \rightsquigarrow 2.3.53
 posetal 1-mesh bundle, \rightsquigarrow 4.1.41ff
 posetal 1-truss bundle, \rightsquigarrow 2.1.85
 positive standard component of
 euclidean space, \rightsquigarrow 1.1.28
 prestratification, \rightsquigarrow B.1.8
 product of cells, §C.2
 product of stratifications, \rightsquigarrow B.2.22
 proframe on a simplex, \rightsquigarrow 3.2.1
 proframed map, \rightsquigarrow 3.2.11, \rightsquigarrow 3.2.27
 proframed map of proframed
 simplices, \rightsquigarrow 3.2.11

proframed map of proframed simplicial
 complexes, \rightsquigarrow 3.2.27
 proframed realization, \rightsquigarrow 3.2.9
 proframed simplicial complex, \rightsquigarrow 3.2.25
 proframing of simplicial
 complexes, \rightsquigarrow 3.2.25
 progressive framing, \rightsquigarrow 1.2.37, \rightsquigarrow 2.1.5
 progressive framing of fences, \rightsquigarrow 2.1.5
 progressive regular cell complex, \rightsquigarrow 1.3.40
 projected tame embedding, \rightsquigarrow 5.2.30
 pullback n -mesh bundle, \rightsquigarrow 4.1.93
 pullback n -truss bundle, \rightsquigarrow 2.3.54
 pullback 1-mesh bundle, \rightsquigarrow 4.1.57
 pullback 1-truss bundle, \rightsquigarrow 2.1.103
 pullback labeled n -truss bundle, \rightsquigarrow 2.3.54
 pullback labeled 1-truss bundle, \rightsquigarrow 2.2.76
 pullback mesh, \rightsquigarrow 5.2.24
 pullback mesh bundle, \rightsquigarrow 4.1.57, \rightsquigarrow 4.1.93
 pullback sequence, \rightsquigarrow A.1.10
 pullback stratification, \rightsquigarrow B.2.26
 pullback stratified bundle, \rightsquigarrow B.2.28
 pullback truss bundle, \rightsquigarrow 2.1.103,
 \rightsquigarrow 2.2.76, \rightsquigarrow 2.3.54
 pure poset of dimension m , \rightsquigarrow 3.3.20
 pure simplicial complex of dimension
 m , \rightsquigarrow 3.3.20
 purely regular section, \rightsquigarrow 2.2.12
 purely singular section, \rightsquigarrow 2.2.12
 pushforward mesh, \rightsquigarrow 5.2.24

Q

quadratic 2-cell, §C.1
 quasicategory, \rightsquigarrow 2.2.75, \rightsquigarrow 4.1.96
 quasicategory of n -mesh
 bordisms, \rightsquigarrow 4.1.100
 quasicategory of labeled 1-trusses and
 their bordisms, \rightsquigarrow 2.2.75
 quotient map of posets, \rightsquigarrow 5.3.3, \rightsquigarrow B.1.36
 quotient map to a poset, \rightsquigarrow B.1.35
 quotient simplicial complex, \rightsquigarrow 1.2.23

R

n -realization of n -mesh bundles, \rightsquigarrow 4.1.77
 n -realization, \rightsquigarrow 4.1.70, \rightsquigarrow 4.1.77
 1-realization of families of
 manifolds, \rightsquigarrow 4.1.23
 1-realization, \rightsquigarrow 4.1.23
 1-realized manifold, \rightsquigarrow 4.1.3ff

- radial catchment path, [↔4.2.32](#)
 - ravioli cell, [§C.2](#)
 - realization, [§4.2.5](#), [↔B.1.51](#)
 - realization bounds, [↔4.1.15](#), [↔4.1.25](#)
 - realization bounds of 1-mesh family, [↔4.1.25](#)
 - realization of n -truss bundle maps, [↔4.2.72](#)
 - realization of n -truss bundles, [↔4.2.71](#)
 - realization of n -truss maps, [↔4.2.59](#)
 - realization of n -trusses, [↔4.2.52](#)
 - realization of closed n -truss bundles, [↔4.2.69](#)
 - realization of closed truss coarsenings, [↔4.2.76](#)
 - realization of maps of closed n -truss bundles, [↔4.2.70](#)
 - realization of posets, [↔B.1.51](#)
 - realization of truss coarsenings, [↔4.2.78](#)
 - reasonable regularity, [↔B.1.32](#)
 - reasonably regular stratification, [↔4.1.36](#)
 - recursive category of C-labeled n -trusses and their bordisms, [↔2.3.24](#)
 - refinement, [↔B.2.4](#)
 - refinement of n -trusses, [↔2.3.67](#)
 - refinement of stratifications, [↔B.2.4](#)
 - refining an embedding, [↔5.2.27](#)
 - refining mesh, [↔5.1.1](#)
 - regular m -cell, [↔1.3.17](#)
 - regular n -mesh bundle map, [↔4.1.89](#)
 - regular n -truss bundle map, [↔2.3.37](#)
 - regular 1-mesh bundle map, [↔4.1.52](#)
 - regular 1-mesh map, [↔4.1.18](#)
 - regular 1-truss bundle map, [↔2.1.88](#)
 - regular 1-truss map, [↔2.1.17](#)
 - regular block complex, [↔2.3.91](#)
 - regular cell complex, [↔1.3.8](#)
 - regular cell complex associated to a cellular poset, [↔1.3.27](#)
 - regular contour, [↔4.2.29](#)
 - regular determined 1-truss bordism, [↔2.1.63](#)
 - regular element, [↔2.1.13](#), [↔2.1.76](#)
 - regular element of 1-truss, [↔2.1.13](#)
 - regular element of 1-truss bundles, [↔2.1.76](#)
 - regular element set, [↔2.1.13](#), [↔2.1.76](#)
 - regular element set of 1-truss bundles, [↔2.1.76](#)
 - regular endpoint-preserving 1-truss map, [↔2.1.67](#)
 - regular function of a 1-truss bordism, [↔2.1.34](#)
 - regular labeled n -truss bundle map, [↔2.3.37](#)
 - regular labeled 1-truss bundle map, [↔2.2.62](#)
 - regular map, [↔2.1.17](#), [↔2.2.62](#), [↔2.3.37](#), [↔4.1.18](#), [↔4.1.89](#)
 - regular stratum, [↔4.1.26](#)
 - regular-endpoint-preserving function, [↔2.1.62](#)
 - relabeling functor, [↔2.2.48](#)
 - relation fully relating elements, [↔2.1.64](#)
 - representable boolean profunctor, [↔2.1.42](#)
 - restricted frame, [↔1.1.57](#)
 - restriction of n -mesh bundles, [↔4.1.94](#)
 - restriction of 1-mesh bundles over strata, [↔4.1.33](#)
 - restriction of 1-truss bundles, [↔2.1.91](#)
 - restriction of labeled n -truss bundles, [↔2.3.40](#)
 - restriction of labeled 1-truss bundles, [↔2.2.65](#)
 - restriction of labeled truss bundles, [↔2.2.65](#), [↔2.3.40](#)
 - restriction of simplicial complex framings, [↔1.2.19](#)
 - restriction of simplicial frames, [↔1.1.53](#), [↔1.1.59](#)
 - restriction of simplicial maps to faces, [↔1.1.58](#)
 - restriction of stratifications, [↔B.2.7](#)
 - restriction sequence, [↔A.1.11](#)
 - retractable compactification, [↔4.2.49](#)
- S**
-
- P -stratification, [↔B.1.48](#)
 - k -stage, [↔2.3.2](#)
 - m -simplex, [↔1.1.1](#)
 - 2-simplex cell, [§C.1](#)
 - scaffold norm, [↔2.2.25](#), [↔2.2.34](#)
 - scaffold norm of sections, [↔2.2.25](#)
 - scaffold norm of spacers, [↔2.2.34](#)
 - scaffold order, [↔2.2.29](#), [↔2.2.35](#)
 - scaffold order of sections, [↔2.2.29](#)
 - scaffold order of spacers, [↔2.2.35](#)
 - section cell, [↔3.3.1](#)
 - section of 1-truss bundle, [↔2.2.1](#)
 - section simplex in proframings, [↔3.2.38](#)
 - semi-simplicial set, [↔1.2.6](#)

- semi-symmetric set, \rightsquigarrow 1.2.6
- semifunctoriality of cubical
 - compactification, \rightsquigarrow 4.2.57
- set of numerals, \rightsquigarrow 1.1.10
- set-to-stratifications analogy, \rightsquigarrow B.3.18
- shellability of framed regular
 - cells, \rightsquigarrow 3.3.31
- shellable poset, \rightsquigarrow 3.3.21
- simplex, \rightsquigarrow 1.1.1
- simplicial complex, \rightsquigarrow 1.2.1
- simplicial map, \rightsquigarrow 1.1.2, \rightsquigarrow 1.1.3, \rightsquigarrow 1.2.2, \rightsquigarrow 1.2.4
- simplicial map of ordered simplicial
 - complexes, \rightsquigarrow 1.2.4
- simplicial map of simplicial
 - complexes, \rightsquigarrow 1.2.2
- simplicial retraction, \rightsquigarrow 1.1.21
- simplicial set, \rightsquigarrow 1.2.6
- simplicial vector, \rightsquigarrow 1.1.11
- simplicial vector addition, \rightsquigarrow 1.1.12
- simplicial vector negation, \rightsquigarrow 1.1.12
- singular n -mesh bundle map, \rightsquigarrow 4.1.89
- singular n -truss bundle map, \rightsquigarrow 2.3.37
- singular 1-mesh bundle map, \rightsquigarrow 4.1.52
- singular 1-mesh map, \rightsquigarrow 4.1.18
- singular 1-truss bundle map, \rightsquigarrow 2.1.88
- singular 1-truss map, \rightsquigarrow 2.1.17
- singular determined 1-truss
 - bordism, \rightsquigarrow 2.1.63
- singular element, \rightsquigarrow 2.1.13, \rightsquigarrow 2.1.76
- singular element of 1-truss, \rightsquigarrow 2.1.13
- singular element of 1-truss
 - bundles, \rightsquigarrow 2.1.76
- singular element set, \rightsquigarrow 2.1.13, \rightsquigarrow 2.1.76
- singular element set of 1-truss
 - bundles, \rightsquigarrow 2.1.76
- singular endpoint-preserving 1-truss
 - map, \rightsquigarrow 2.1.67
- singular function of a 1-truss
 - bordism, \rightsquigarrow 2.1.34
- singular labeled n -truss bundle
 - map, \rightsquigarrow 2.3.37
- singular labeled 1-truss bundle
 - map, \rightsquigarrow 2.2.62
- singular map, \rightsquigarrow 2.1.17, \rightsquigarrow 2.2.62, \rightsquigarrow 2.3.37, \rightsquigarrow 4.1.18, \rightsquigarrow 4.1.89
- singular stratum, \rightsquigarrow 4.1.26
- singular-endpoint-preserving
 - function, \rightsquigarrow 2.1.62
- singularity, \rightsquigarrow 5.3.14, \rightsquigarrow 5.3.67, \rightsquigarrow 5.4.30ff
- space of framed subdivisions, \rightsquigarrow 4.2.91
- spacer cell, \rightsquigarrow 3.3.1
- spacer of 1-truss bundle, \rightsquigarrow 2.2.2
- spacer simplex in proframings, \rightsquigarrow 3.2.38
- specialization labeling, \rightsquigarrow B.1.43
- specialization order, \rightsquigarrow B.1.4
- specialization topology, \rightsquigarrow B.1.1
- spine, §1.1, \rightsquigarrow 1.1.13, \rightsquigarrow 1.1.14
- spine vector, \rightsquigarrow 1.1.13
- spine vector of an ordered
 - simplex, \rightsquigarrow 1.1.14
- stage functorial relation, \rightsquigarrow 2.3.14
- stage in tower, \rightsquigarrow 2.3.2
- standard m -simplex, \rightsquigarrow 1.1.7, \rightsquigarrow 1.1.9
- standard 1-framed circle, \rightsquigarrow 4.1.1
- standard 1-framed euclidean
 - space, \rightsquigarrow 4.1.1
- standard euclidean indframe, \rightsquigarrow A.1.6
- standard euclidean proframe, \rightsquigarrow 3.2.8, \rightsquigarrow A.1.7
- standard geometric m -simplex, \rightsquigarrow A.2.4
- standard ordered m -simplex, \rightsquigarrow 1.1.7
- standard oriented component of
 - euclidean space, \rightsquigarrow 1.1.28
- star, \rightsquigarrow 1.2.36, \rightsquigarrow B.3.28
- star in a regular cell complex, \rightsquigarrow B.3.28
- star of a vertex in a simplicial
 - complex, \rightsquigarrow 1.2.36
- stratification, \rightsquigarrow B.1.8
- stratification coarsening of stratified
 - meshes, \rightsquigarrow 5.3.18
- stratification from poset labeling, \rightsquigarrow 5.3.6
- stratified n -mesh, \rightsquigarrow 5.3.16
- stratified n -truss, \rightsquigarrow 5.1.21
- stratified n -truss bundle, \rightsquigarrow 5.3.41
- stratified bundle, \rightsquigarrow B.2.24
- stratified cone, \rightsquigarrow B.3.1
- stratified map, \rightsquigarrow B.2.1
- stratified map realization of poset
 - maps, \rightsquigarrow 1.3.5
- stratified mesh, \rightsquigarrow 5.3.16
- stratified mesh coarsening
 - realization, \rightsquigarrow 5.3.30
- stratified mesh map, \rightsquigarrow 5.3.17
- stratified mesh map realization, \rightsquigarrow 5.3.27
- stratified mesh realization, \rightsquigarrow 5.3.26
- stratified pullback, \rightsquigarrow B.2.26
- stratified realization, \rightsquigarrow 1.3.4
- stratified realization ∞ -functor, \rightsquigarrow B.2.21
- stratified realization functor, \rightsquigarrow B.2.14
- stratified realization of posets, \rightsquigarrow 1.3.4, \rightsquigarrow B.1.52
- stratified truss, \rightsquigarrow 5.1.21
- stratified truss bundle, §5.3.1.5, \rightsquigarrow 5.3.41
- stratum of stratified truss, \rightsquigarrow 5.3.1
- strict upper closure, \rightsquigarrow 1.3.2

- subbundle of n -mesh bundles, \rightsquigarrow 4.1.90
 - subbundle of n -truss bundles, \rightsquigarrow 2.3.65
 - subdivision, \rightsquigarrow 4.2.86, \rightsquigarrow B.3.32
 - subdivision of regular cell, \rightsquigarrow 4.2.86
 - subframed map, \rightsquigarrow 1.1.75, \rightsquigarrow 1.3.59
 - subframed map of framed
 - simplices, \rightsquigarrow 1.1.75
 - subframed map of framed simplicial
 - complexes, \rightsquigarrow 1.2.20
 - submesh, \rightsquigarrow 4.1.19, \rightsquigarrow 4.1.90
 - submesh of n -meshes, \rightsquigarrow 4.1.90
 - submesh of 1-meshes, \rightsquigarrow 4.1.19
 - subproframed map, \rightsquigarrow 3.2.13
 - subsimplex, \rightsquigarrow 1.1.5
 - substratification, \rightsquigarrow B.2.6
 - subtruss, \rightsquigarrow 2.3.61, \rightsquigarrow 2.3.65
 - subtruss of n -trusses, \rightsquigarrow 2.3.65
 - subtruss of 1-trusses, \rightsquigarrow 2.3.61
 - sufficiently nice stratification, \rightsquigarrow 5.2.6
 - support of a 1-realized manifold, \rightsquigarrow 4.1.4
 - support of an n -realized mesh, \rightsquigarrow 4.1.71
 - support of an n -realized mesh
 - bundle, \rightsquigarrow 4.1.78
 - suspended section, \rightsquigarrow 2.2.16
 - suspension functor, \rightsquigarrow 2.1.110, \rightsquigarrow 2.1.111
 - suspension of n -truss bundles, \rightsquigarrow 2.3.60
 - suspension of 1-truss bundles, \rightsquigarrow 2.1.111
 - suspension of labeled 1-truss
 - bundles, \rightsquigarrow 2.2.81
 - suspension of posets, \rightsquigarrow 2.1.110
 - symmetric set, \rightsquigarrow 1.2.6
- t**
-
- (n, k) -truncation, \rightsquigarrow B.3.11
 - Top-enriched category, \rightsquigarrow 4.1.96
 - Top-tensoredness of
 - stratifications, \rightsquigarrow B.2.23
 - k Top-enriched category of n -truss
 - bundles, \rightsquigarrow 2.3.39
 - k Top-enriched category of
 - n -trusses, \rightsquigarrow 2.3.39
 - k Top-enriched category of locally finite
 - posets, \rightsquigarrow B.2.18
 - k Top-enriched category of
 - stratifications, \rightsquigarrow B.2.17
 - i -truncation of n -mesh bundles, \rightsquigarrow 4.1.80
 - i -truncation of n -truss bundles, \rightsquigarrow 2.3.42,
 - \rightsquigarrow 2.3.43
 - i -truncation of proframed maps, \rightsquigarrow 3.2.29
 - i -truncation of proframings, \rightsquigarrow 3.2.29
 - i -truncation, \rightsquigarrow 2.3.42, \rightsquigarrow 2.3.43, \rightsquigarrow 4.1.80
 - n -tame m -cell, \rightsquigarrow 5.3.66ff
 - n -tame m -singularity, \rightsquigarrow 5.3.67ff
 - n -tame m -tangle, \rightsquigarrow 5.4.22
 - n -tame embedding, \rightsquigarrow 5.1.4
 - n -tame stratification, \rightsquigarrow 5.1.1
 - n -truss m -block, \rightsquigarrow 2.3.73
 - n -truss m -brace, \rightsquigarrow 2.3.100
 - n -truss m -cell, \rightsquigarrow 5.3.14
 - n -truss m -singularity, \rightsquigarrow 5.3.14
 - n -truss block complex, \rightsquigarrow 2.3.90
 - n -truss bordism, \rightsquigarrow 2.3.9
 - n -truss bundle, \rightsquigarrow 2.3.27
 - n -truss regular block complex, \rightsquigarrow 2.3.91
 - n -truss, \rightsquigarrow 2.3.1, \rightsquigarrow 2.3.2
 - 0-truncated stratification, \rightsquigarrow B.3.17
 - 0-truncatedness of cellular
 - stratifications, \rightsquigarrow B.3.31
 - 1-truss (linear), \rightsquigarrow 2.1.10
 - 1-truss bordism, \rightsquigarrow 2.1.33
 - 1-truss bundle bordism, \rightsquigarrow 2.1.96
 - 1-truss bundle isobordism, \rightsquigarrow 2.1.98
 - 1-truss bundle, \rightsquigarrow 2.1.74
 - 1-truss isobordism, \rightsquigarrow 2.1.55
 - 1-truss map, \rightsquigarrow 2.1.16
 - 1-truss, \rightsquigarrow 2.1.6, \rightsquigarrow 2.1.10
 - tame cell, \rightsquigarrow 5.3.66
 - tame embedding, \rightsquigarrow 5.1.4
 - tame immersion, \rightsquigarrow 5.1.14
 - tame open neighborhood, \rightsquigarrow 5.1.5
 - tame singularity, \rightsquigarrow 5.3.67
 - tame stratification, \rightsquigarrow 5.1.1
 - tame stratified bundle, §5.3.1.5, \rightsquigarrow 5.3.38
 - tame submersion, \rightsquigarrow 5.1.13
 - tame tangle, §5.4, \rightsquigarrow 5.4.22
 - tame tangle isotopy, \rightsquigarrow 5.4.33
 - tame tangle singularity, \rightsquigarrow 5.4.22,
 - \rightsquigarrow 5.4.30
 - tangential neighborhood, \rightsquigarrow B.3.2
 - tangle isotopy, \rightsquigarrow 5.4.33
 - tangle singularity, \rightsquigarrow 5.4.30
 - tautological 1-truss bundle, \rightsquigarrow 2.2.55
 - terminal n -truss, \rightsquigarrow 2.3.22
 - thickened 2-cube cell, §C.2
 - thickened 2-simplex cell, §C.2
 - thin poset, \rightsquigarrow 3.3.22
 - top section, \rightsquigarrow 2.2.27
 - topological stratification, \rightsquigarrow B.3.4
 - total 1-truss bundle, \rightsquigarrow 2.1.93
 - total diposet, \rightsquigarrow 2.1.74
 - total diposet of a 1-truss
 - bundle, \rightsquigarrow 2.1.74
 - total labeled n -truss bundle, \rightsquigarrow 2.3.45
 - total labeled 1-truss bundle, \rightsquigarrow 2.2.68

total poset, \rightsquigarrow 2.1.72, \rightsquigarrow 2.1.74, \rightsquigarrow 2.3.2,
 \rightsquigarrow 2.3.9ff
total poset of a 1-truss bordism, \rightsquigarrow 2.1.72
total poset of a 1-truss bundle, \rightsquigarrow 2.1.74
total poset of an n -truss, \rightsquigarrow 2.3.2
total poset of an n -truss
bordism, \rightsquigarrow 2.3.9ff
total poset of an n -truss bundle, \rightsquigarrow 2.3.27
total stratification, \rightsquigarrow B.2.24ff
totalization functor, \rightsquigarrow 2.1.100, \rightsquigarrow 2.2.73,
 \rightsquigarrow 2.3.52
totalization functor for 1-truss
bundles, \rightsquigarrow 2.1.100
totalization functor for categorical
labeled n -truss bundles, \rightsquigarrow 2.3.53
totalization functor for categorical
labeled 1-truss bundles, \rightsquigarrow 2.2.74
totalization functor for labeled n -truss
bundles, \rightsquigarrow 2.3.52
totalization functor for labeled 1-truss
bundles, \rightsquigarrow 2.2.73
tower of 1-mesh bundles, \rightsquigarrow 4.1.76
tower of 1-truss bundles, \rightsquigarrow 2.3.2
tower of bundles, \rightsquigarrow 2.3.2, \rightsquigarrow 4.1.76
transition arrow, \rightsquigarrow 2.2.12
transition functor, \rightsquigarrow 3.2.41
transition functor of fiber categories of
proframings, \rightsquigarrow 3.2.41
transition index, \rightsquigarrow 2.2.12
translation vector, \rightsquigarrow A.2.1
transversal embedding, §5.4.1.2
transversal singularity, §5.4.1.2
transversal tame singularity, \rightsquigarrow 5.4.10
trivial 1-mesh, \rightsquigarrow 4.1.10
trivial 1-truss, \rightsquigarrow 2.1.7
trivial circular 1-truss, \rightsquigarrow 2.1.7
trivial closed 1-truss, \rightsquigarrow 2.1.23
trivial fence, \rightsquigarrow 2.1.2
trivial linear 1-truss, \rightsquigarrow 2.1.7
trivial open 1-truss, \rightsquigarrow 2.1.23
trivialization of 1-mesh bundles over
strata, \rightsquigarrow 4.1.34
truncation, \rightsquigarrow 2.3.42, \rightsquigarrow 2.3.43, \rightsquigarrow 4.1.80
truncation of proframed maps, \rightsquigarrow 3.2.29
truncation of proframings, \rightsquigarrow 3.2.29
truncation of truss bundles, \rightsquigarrow 2.3.42,
 \rightsquigarrow 2.3.43
truss, \rightsquigarrow 2.1.6, \rightsquigarrow 2.3.1
truss block, \rightsquigarrow 2.3.73
truss brace, \rightsquigarrow 2.3.100
truss bundle, \rightsquigarrow 2.1.74, \rightsquigarrow 2.2.57, \rightsquigarrow 2.3.31
truss cell, \rightsquigarrow 5.3.14

truss coarsening of stratified
trusses, \rightsquigarrow 5.3.11
truss integration functor, \rightsquigarrow 3.3.27
truss product, \rightsquigarrow 2.3.55
truss singularity, \rightsquigarrow 5.3.14
tubular neighborhood, \rightsquigarrow B.3.2

u

underlying n -truss, \rightsquigarrow 2.3.6
underlying n -truss bordism, \rightsquigarrow 2.3.11
underlying n -truss bundle, \rightsquigarrow 2.3.31
underlying n -truss bundle
map, \rightsquigarrow 2.3.32ff
underlying 1-truss, \rightsquigarrow 2.2.39
underlying 1-truss bordism, \rightsquigarrow 2.2.40
underlying 1-truss bundle, \rightsquigarrow 2.2.57
underlying 1-truss bundle
map, \rightsquigarrow 2.2.60ff
underlying relation functor, \rightsquigarrow 2.1.40
underlying relation of a boolean
profunctor, \rightsquigarrow 2.1.40
underlying simplicial complex of cellular
poset, \rightsquigarrow 1.3.29
underlying truss, \rightsquigarrow 2.2.39, \rightsquigarrow 2.3.6
underlying truss bordism, \rightsquigarrow 2.2.40,
 \rightsquigarrow 2.3.11
underlying truss bundle, \rightsquigarrow 2.2.57,
 \rightsquigarrow 2.3.31
unframed subspace, \rightsquigarrow 1.1.35, \rightsquigarrow 3.2.3ff
unframed subspace of a partially framed
simplex, \rightsquigarrow 1.1.35
unframed subspace of an embedded
partially framed simplex, \rightsquigarrow 1.1.48
unframing, \rightsquigarrow 1.2.18
unframing of framed simplicial
complexes, \rightsquigarrow 1.2.18
unlabeled 1-truss bundle, \rightsquigarrow 2.2.64
unordered m -simplex, \rightsquigarrow 1.1.1
unordered simplex, \rightsquigarrow 1.1.1
unordered standard m -simplex, \rightsquigarrow 1.1.9
unordering functor, \rightsquigarrow 1.1.4
unordering simplicial complexes, \rightsquigarrow 1.2.5
upper central section cell, \rightsquigarrow 3.3.7
upper closure, \rightsquigarrow 1.3.2
upper endpoint, \rightsquigarrow 2.1.22
upper endpoint of 1-trusses, \rightsquigarrow 2.1.22
upper fiber bound, \rightsquigarrow 5.2.17
upper realization bound, \rightsquigarrow 4.1.15,
 \rightsquigarrow 4.1.25
upper section, \rightsquigarrow 3.2.39, \rightsquigarrow 3.3.5
upper section of spacer cells, \rightsquigarrow 3.3.5

upper section of spacer
 simplices, \rightsquigarrow 3.2.39
upper truncation of truss
 bundles, \rightsquigarrow 2.3.42

V

k -vector of frame, \rightsquigarrow 1.2.11
vector of a simplex, \rightsquigarrow 1.1.11
vertical comma category, \rightsquigarrow 2.2.53

Z

Z -family of 1-mesh bundles, \rightsquigarrow 4.2.37ff
 z -slice, \rightsquigarrow 4.2.37ff